



1500W With Parallel Function

**SCN-1K5 series**

#### ■ Features :

- AC 200~260V input only
- Protections: Short circuit/ Over voltage/Over load/ Over temp.
- High reliability/ Low ripple noise
- Built-in remote sense function
- Built-in remote ON-OFF control
- With parallel function
- Can adjust from 20~100% output voltage by external control 1-5V
- Forced air cooling by built-in DC fan
- Case coating with paint
- 2 years warranty

Parallel

### SPECIFICATION

ORDER NO.	SCN-1K5-12	SCN-1K5-15	SCN-1K5-24	SCN-1K5-48	
OUTPUT	MODEL NO.	1K5S-N012	1K5S-N015	1K5S-N024	1K5S-N048
	DC VOLTAGE	12V	15V	24V	48V
	RATED CURRENT	125A	100A	62.5A	32A
	CURRENT RANGE	0 ~ 125A	0 ~ 100A	0 ~ 62.5A	0 ~ 32A
	RATED POWER	1500W	1500W	1500W	1536W
	RIPPLE & NOISE (max.) Note.2	120mVp-p	150mVp-p	240mVp-p	480mVp-p
	VOLTAGE ADJ. RANGE	±5.0% typical adjustment by potentiometer 20~100% adjustment by 1~5VDC external control			
	VOLTAGE TOLERANCE Note.3	±1.0%	±1.0%	±1.0%	±1.0%
	LINE REGULATION	±0.5%	±0.5%	±0.5%	±0.5%
	LOAD REGULATION	±0.5%	±0.5%	±0.5%	±0.5%
SETUP, RISE, HOLD TIME	800ms, 50ms, 16ms at full load				
INPUT	VOLTAGE RANGE	200 ~ 260VAC 290~370VDC			
	FREQUENCY RANGE	47~63Hz			
	EFFICIENCY (Typ.)	83%	84%	85%	87%
	AC CURRENT	12A / 230VAC			
	INRUSH CURRENT (max.)	120A / 230VAC			
	LEAKAGE CURRENT(max.)	3.5mA / 240VAC			
PROTECTION	OVER LOAD	110~135% rated output power Protection type : Current limiting, delay shut down o/p voltage, re-power on to recover			
	OVER VOLTAGE	110~135% follow to output set up point Protection type : Shut down o/p voltage, re-power on to recover			
	OVER TEMPERATURE	>100°C / measure by heat sink, near transformer Protection type : Shut down o/p voltage, re-power on to recover			
ENVIRONMENT	WORKING TEMP.	-10~+65°C (Refer to output load derating curve)			
	WORKING HUMIDITY	20%~90% RH non-condensing			
	STORAGE TEMP., HUMIDITY	-20~+85°C 10~95% RH			
	TEMP. COEFFICIENT	±0.04% / °C (0~50°C)			
	VIBRATION	10~200Hz, 2G 10min./1cycle, period for 60min. each along X, Y, Z axes			
SAFETY & EMC (Note. 4)	SAFETY STANDARDS	Design refer to UL1950, CSA22.2, IEC60950			
	WITHSTAND VOLTAGE	I/P-O/P, I/P-FG:1500VAC			
	ISOLATION RESISTANCE	I/P-O/P, I/P-FG, >100M Ohms / 500VDC			
	EMI CONDUCTION & RADIATION	Design refer to FCC part 15 class A			
	HARMONIC CURRENT	----			
	EMS IMMUNITY	----			
OTHERS	MTBF	60khrs min. MIL-HDBK-217F (25°C)			
	DIMENSION	291*132*132mm (L*W*H)			
	PACKING	4.5kg; 4pcs / 20kg / CARTON			
	SPECIAL FUNCTION	DC voltage adj., Remote sensing, remote control, parallel operation (refer to terminal instruction manual)			
NOTE	<p>1.All parameters are specified at 230VAC input, rated load, 25°C 70% RH. Ambient.</p> <p>2.Tolerance: includes set up tolerance, line regulation, load regulation.</p> <p>3.Ripple &amp; noise are measured at 20MHz by using a 12" twisted pair terminated with a 0.1uf &amp; 47uf capacitor.</p> <p>4.The power supply is considered a component which will be installed into a final equipment. The final equipment must be re-confirmed that it still meets EMC directives.</p>				

File Name:SCN-1K5-SPEC 2004-01-08

## Mechanical Specification

Unit:mm

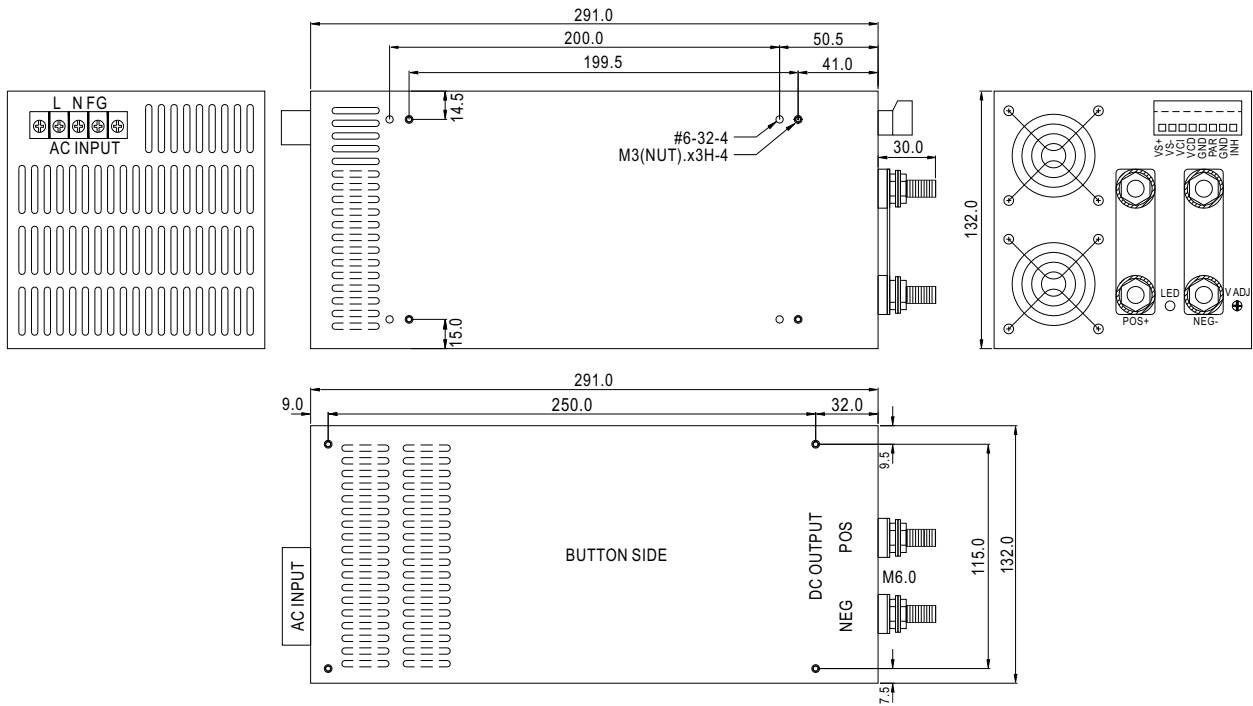

Terminal Pin. No. Assignment

Pin No.	Assignment
1	AC/L
2	AC/N
3	FG $\perp$

Control terminal Pin. No. Assignment (CN1) : Dinkle 51HDBC-O8P or equivalent

Pin No.	Assignment	Pin No.	Assignment	Mating With
1	VS+	5	GND	Dinkle 51SDB-O8P or equivalent
2	VS-	6	PAR	
3	VCI	7	GND	
4	VCO	8	INH	

## Derating Curve

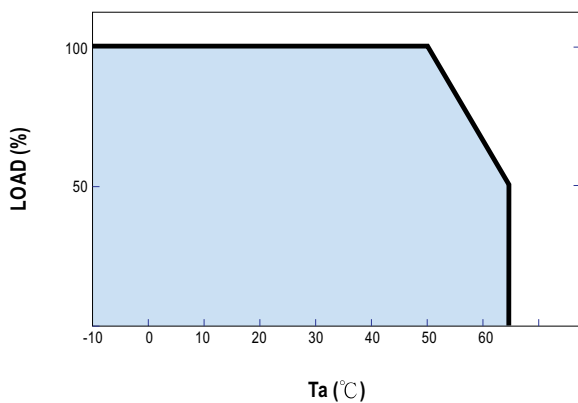

## External DC Control VS Output Voltage

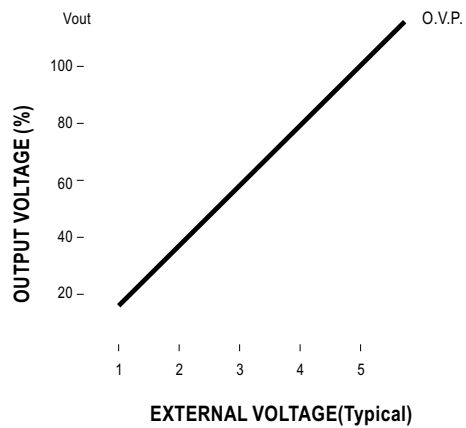



1500W With Parallel Function

SCN-1K5 series

Control terminal instruction manual

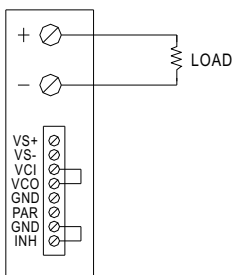

USING INTERNAL VOLTAGE CONTROL

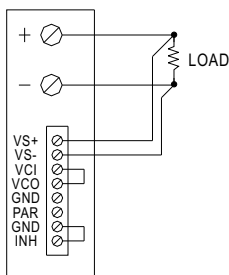

REMOTE SENSING

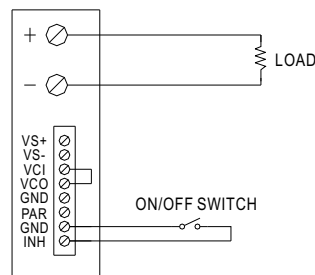

ON/OFF CONTROL BY SWITCH

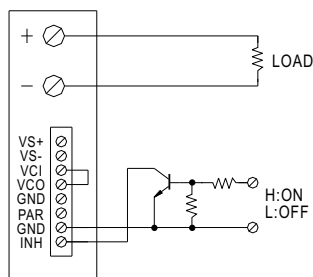

ON/OFF CONTROL BY TRANSISTOR

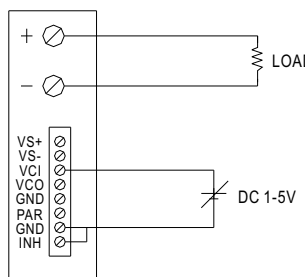

OUTPUT VOLTAGE ADJUST WITH DC 1-5V

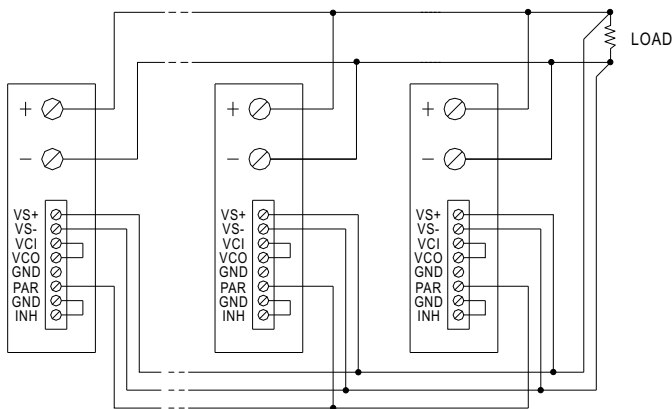

PARALLEL OPERATION WITH REMOTE SENSING

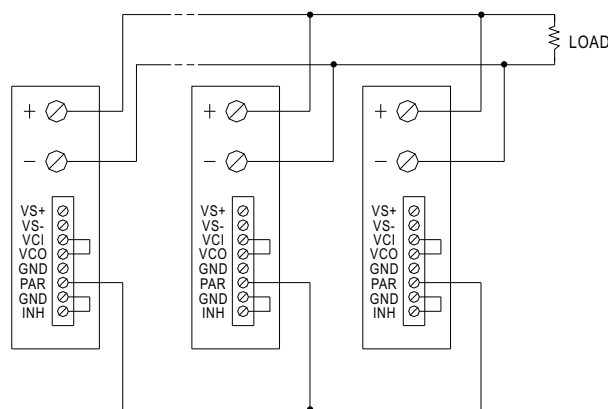

PARALLEL OPERATION