

GU SOP 1 Form B (AQV414S)

REFERENCE DATA

1. Load current vs. ambient temperature characteristics

Allowable ambient temperature: -40°C to $+85^{\circ}\text{C}$
 -40°F to $+185^{\circ}\text{F}$

Type of connection: A

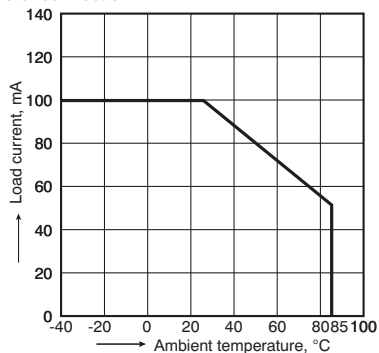

2. On resistance vs. ambient temperature characteristics

Measured portion: between terminals 4 and 6;
 LED current: 0 mA;
 Continuous load current: 100 mA (DC)

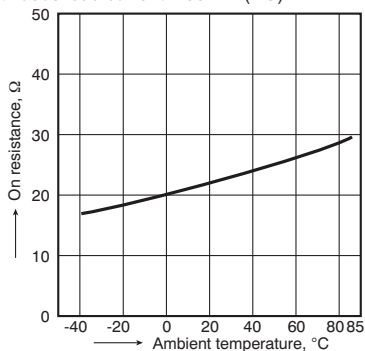

3. Operate (OFF) time vs. ambient temperature characteristics

LED current: 5 mA;
 Load voltage: 400 V (DC);
 Continuous load current: 100 mA (DC)

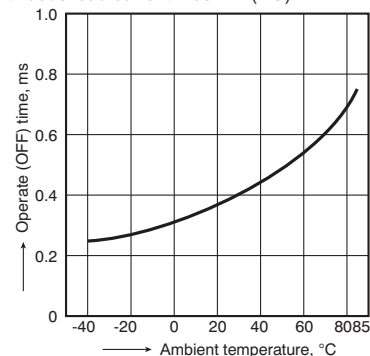

4. Reverse (ON) time vs. ambient temperature characteristics

LED current: 50 mA;
 Load voltage: 400 V (DC);
 Continuous load current: 100 mA (DC)

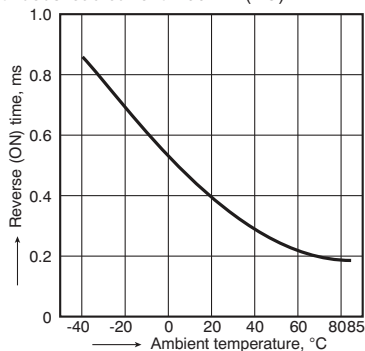

5. LED operate (OFF) current vs. ambient temperature characteristics

Load voltage: 400 V (DC);
 Continuous load current: 100 mA (DC)

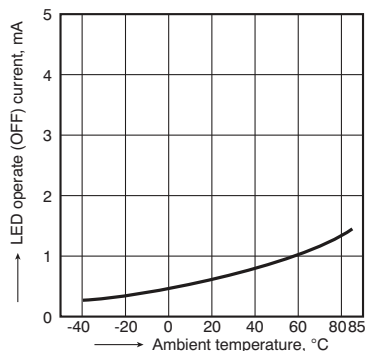

6. LED reverse (ON) current vs. ambient temperature characteristics

Load voltage: 400 V (DC);
 Continuous load current: 100 mA (DC)

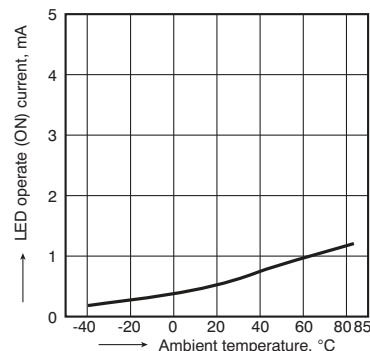

7. LED dropout voltage vs. ambient temperature characteristics

LED current: 5 to 50 mA

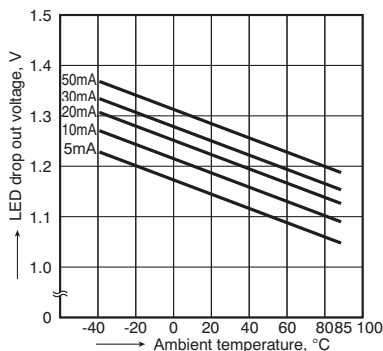

8. Current vs. voltage characteristics of output at MOS portion

Measured portion: between terminals 4 and 6;
 Ambient temperature: 25°C 77°F

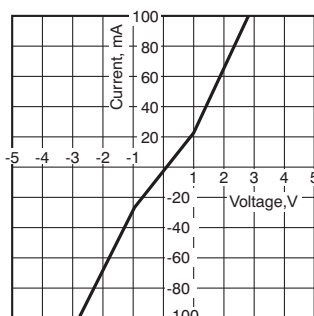

9. Off state leakage current vs. load voltage characteristics

Measured portion: between terminals 4 and 6;
 LED current: 5 mA;
 Ambient temperature: 25°C 77°F

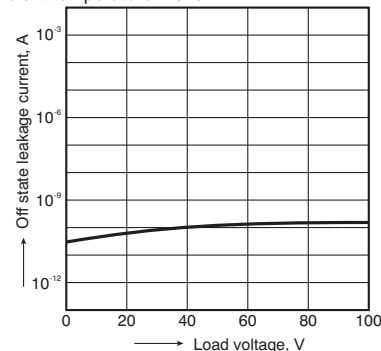

GU SOP 1 Form B (AQV414S)

10. Operate (OFF) time vs. LED forward current characteristics

Measured portion: between terminals 4 and 6;
Load voltage: 400 V (DC); Continuous load current:
100 mA (DC); Ambient temperature: 25°C 77°F

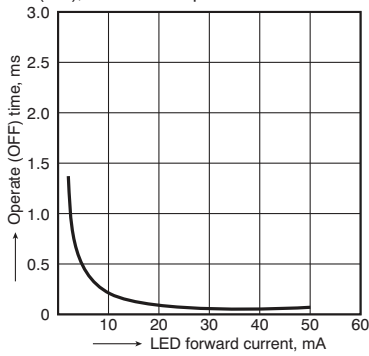

11. Reverse (ON) time vs. LED forward current characteristics

Measured portion: between terminals 4 and 6;
Load voltage: 400 V (DC); Continuous load current:
100 mA (DC); Ambient temperature: 25°C 77°F

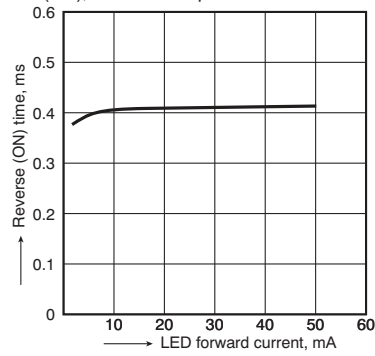

12. Output capacitance vs. applied voltage characteristics

Measured portion: between terminals 4 and 6;
Frequency: 1 MHz;
Ambient temperature: 25°C 77°F

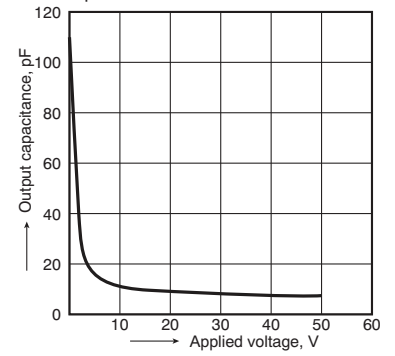

PhotoMOS

Panasonic

ideas for life



Normally closed 6-pin
type of 400V load voltage

PhotoMOS®
GU 1 Form B
(AQV414)

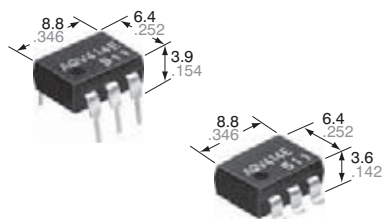

CAD Data

mm inch

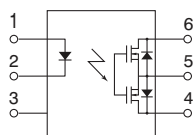

FEATURES

1. Low on-resistance (typ. 26Ω) for normally-closed type

This has been achieved thanks to the built-in MOSFET processed by our proprietary method, DSD (Double-diffused and Selective Doping) method.

3. High sensitivity and low on-resistance

Can control max. 0.15 A load current with 5 mA input current.

4. Low-level off state leakage current of max. 1 μA

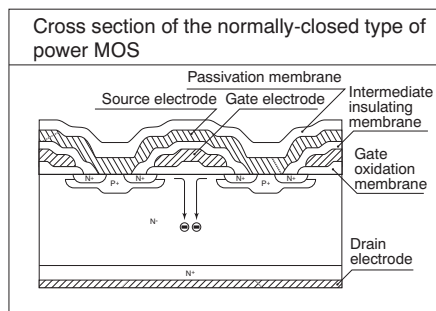

2. Controls low-level analog signals

PhotoMOS relays feature extremely low closed-circuit offset voltage to enable control of low-level analog signals without distortion.

TYPICAL APPLICATIONS

- Security equipment
- Telephone equipment (Dial pulse)
- Measuring instruments

TYPES

	I/O isolation voltage	Output rating*		Package	Part No.				Packing quantity	
		Load voltage	Load current		Through hole terminal	Surface-mount terminal		Tube	Tape and reel	
						Tape and reel packing style				
AC/DC dual use	1,500 V AC	400 V	120 mA	DIP6-pin	AQV414	AQV414A	AQV414AX	AQV414AZ	1 tube contains: 50 pcs. 1 batch contains: 500 pcs.	1,000 pcs.

*Indicate the peak AC and DC values.

Note: The surface mount terminal shape indicator "A" and the packing style indicator "X" or "Z" are not marked on the relay.

RATING

1. Absolute maximum ratings (Ambient temperature: 25°C 77°F)

Item	Symbol	Type of connection	AQV414(A)	Remarks	
Input	LED forward current	I_F	50 mA		
	LED reverse voltage	V_R	5 V		
	Peak forward current	I_{FP}	1 A	f = 100 Hz, Duty factor = 0.1%	
	Power dissipation	P_{in}	75 mW		
Output	Load voltage (peak AC)	V_L	400 V		
	Continuous load current	I_L	A	0.12 A	A connection: Peak AC, DC B, C connection: DC
			B	0.13 A	
			C	0.15 A	
	Peak load current	I_{peak}		0.3 A	A connection: 100 ms (1 shot), $V_L = DC$
Power dissipation	P_{out}		500 mW		
Total power dissipation	P_T		550 mW		
I/O isolation voltage	V_{iso}		1,500 V AC		
Temperature limits	Operating	T_{opr}	-40°C to +85°C -40°F to +185°F	Non-condensing at low temperatures	
	Storage	T_{stg}	-40°C to +100°C -40°F to +212°F		

GU 1 Form B (AQV414)

2. Electrical characteristics (Ambient temperature: 25°C 77°F)

Item			Symbol	Type of connection	AQV414(A)	Condition
Input	LED operate (OFF) current	Typical	I_{Foff}	—	1.0 mA	$I_L = 120 \text{ mA}$
		Maximum			3.0 mA	
	LED reverse (ON) current	Minimum	I_{Fon}	—	0.4 mA	$I_L = 120 \text{ mA}$
		Typical			0.95 mA	
	LED dropout voltage	Typical	V_F	—	1.25 V (1.14 V at $I_F = 5 \text{ mA}$)	$I_F = 50 \text{ mA}$
Maximum		1.5 V				
Output	On resistance	Typical	R_{on}	A	26 Ω	$I_F = 0 \text{ mA}$ $I_L = \text{Max.}$ Within 1 s on time
		Maximum			50 Ω	
		Typical	R_{on}	B	20 Ω	$I_F = 0 \text{ mA}$ $I_L = \text{Max.}$ Within 1 s on time
		Maximum			25 Ω	
	Typical	R_{on}	C	10 Ω	$I_F = 0 \text{ mA}$ $I_L = \text{Max.}$ Within 1 s on time	
	Maximum			12.5 Ω		
	Off state leakage current	Maximum	I_{Leak}	—	1 μA	$I_F = 5 \text{ mA}$ $V_L = 400 \text{ V}$
Transfer characteristics	Operate (OFF) time*	Typical	T_{off}	—	0.47 ms	$I_F = 0 \text{ mA} \rightarrow 5 \text{ mA}$ $I_L = 120 \text{ mA}$
		Maximum			1.0 ms	
	Reverse (ON) time*	Typical	T_{on}	—	0.28 ms	$I_F = 5 \text{ mA} \rightarrow 0 \text{ mA}$ $I_L = 120 \text{ mA}$
		Maximum			1.0 ms	
	I/O capacitance	Typical	C_{iso}	—	0.8 pF	$f = 1 \text{ MHz}$ $V_b = 0 \text{ V}$
		Maximum			1.5 pF	
Initial I/O isolation resistance	Minimum	R_{iso}	—	1,000 M Ω	500 V DC	

*Operate/Reverse time

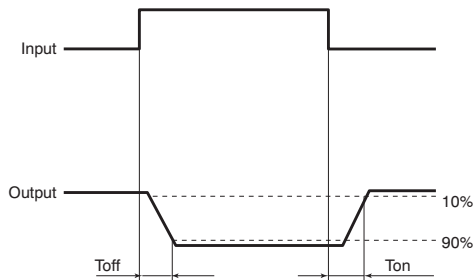

RECOMMENDED OPERATING CONDITIONS

Please obey the following conditions to ensure proper relay operation and resetting.

Item	Symbol	Recommended value	Unit
Input LED current	I_F	5	mA

■ For Dimensions, see page 60.

■ For Schematic and Wiring Diagrams, see page 66.

■ For Cautions for Use, see page 71.

■ These products are not designed for automotive use.

If you are considering to use these products for automotive applications, please contact your local Panasonic technical representative.

For more information, see page 80.

GU 1 Form B (AQV414)

REFERENCE DATA

1. Load current vs. ambient temperature characteristics

Allowable ambient temperature: -40°C to $+85^{\circ}\text{C}$
 -40°F to $+185^{\circ}\text{F}$

Type of connection: A

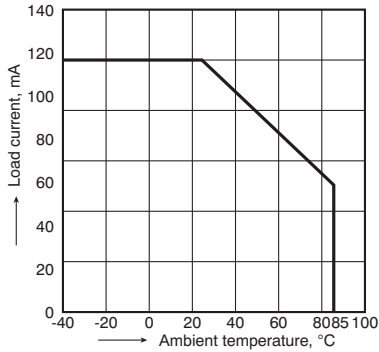

2. On resistance vs. ambient temperature characteristics

Measured portion: between terminals 4 and 6;
 LED current: 0 mA;
 Continuous load current: 120 mA (DC)

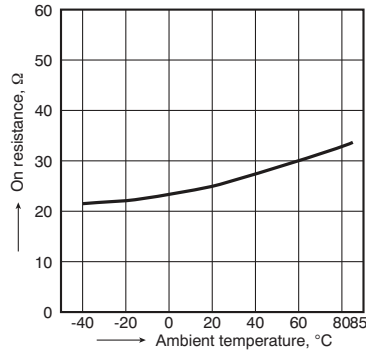

3. Operate (OFF) time vs. ambient temperature characteristics

LED current: 5 mA;
 Load voltage: 400 V (DC);
 Continuous load current: 120 mA (DC)

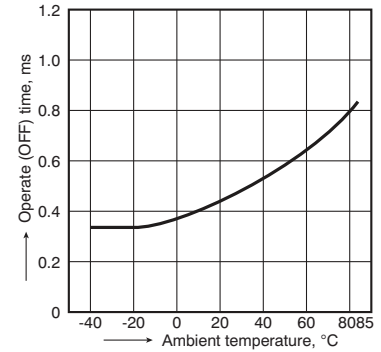

4. Reverse (ON) time vs. ambient temperature characteristics

LED current: 5 mA; Load voltage: 400 V (DC);
 Continuous load current: 120 mA (DC)

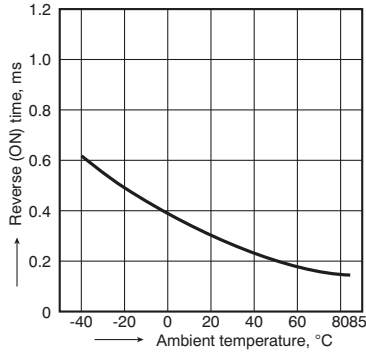

5. LED operate (OFF) current vs. ambient temperature characteristics

Load voltage: 400 V (DC);
 Continuous load current: 120 mA (DC)

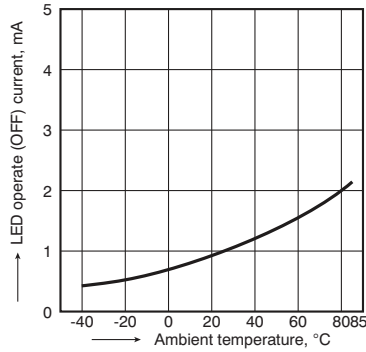

6. LED reverse (ON) current vs. ambient temperature characteristics

Load voltage: 400 V (DC);
 Continuous load current: 120 mA (DC)

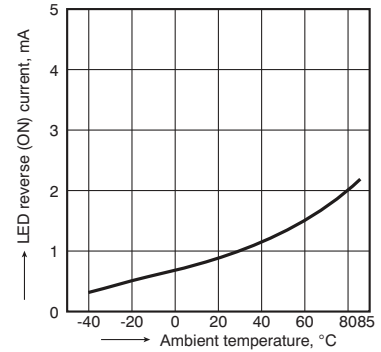

7. LED dropout voltage vs. ambient temperature characteristics

LED current: 5 to 50 mA

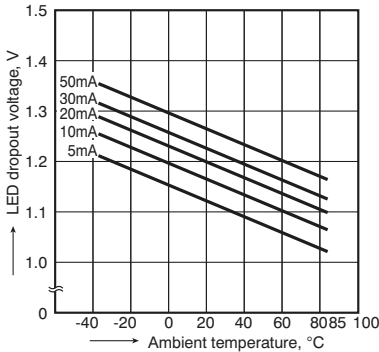

8. Current vs. voltage characteristics of output at MOS portion

Measured portion: between terminals 4 and 6;
 Ambient temperature: 25°C 77°F

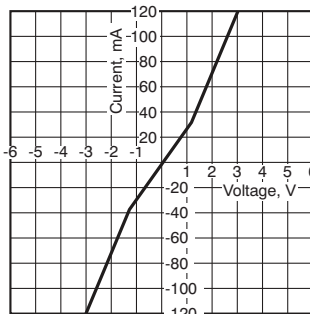

9. Off state leakage current vs. load voltage characteristics

Measured portion: between terminals 4 and 6;
 LED current: 5 mA; Ambient temperature: 25°C 77°F

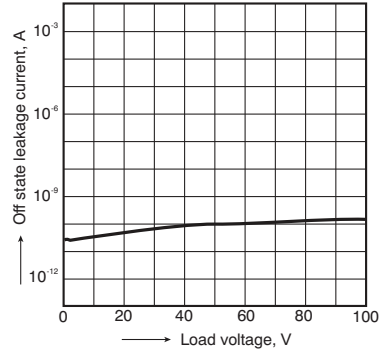

10. Operate (OFF) time vs. LED forward current characteristics

Measured portion: between terminals 4 and 6;
 Load voltage: 400 V (DC); Continuous load current:
 120 mA (DC); Ambient temperature: 25°C 77°F

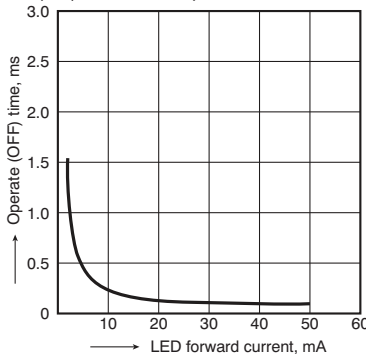

11. Reverse (ON) time vs. LED forward current characteristics

Measured portion: between terminals 4 and 6;
 Load voltage: 400 V (DC); Continuous load current:
 120 mA (DC); Ambient temperature: 25°C 77°F

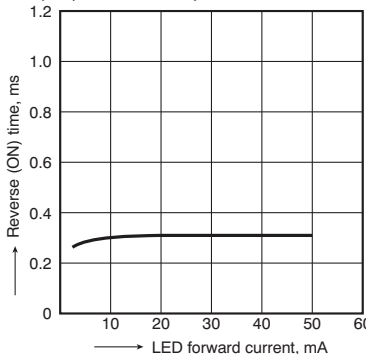

12. Output capacitance vs. applied voltage characteristics

Measured portion: between terminals 4 and 6;
 Frequency: 1 MHz; Ambient temperature: 25°C 77°F

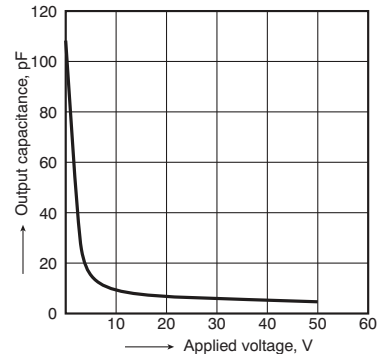

Panasonic

ideas for life



Normally closed
DIP8-pin type
of 400V load voltage

PhotoMOS®
GU 2 Form B
(AQW414)

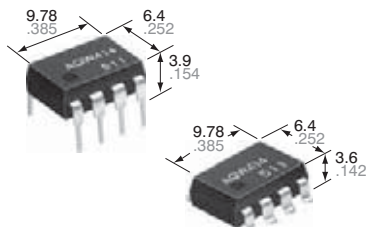

CAD Data

mm inch

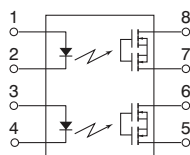

FEATURES

1. Approx. 1/2 the space compared with the mounting of Two 1 Form B PhotoMOS units

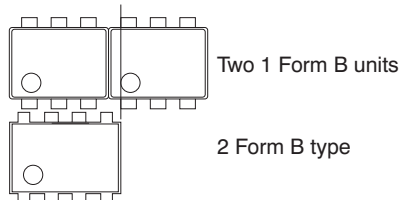

2. Applicable for 2 Form B use as well as two independent 1 Form B use
3. Controls load currents up to 0.13 A with an input current of 5 mA
4. High speed switching: operate time typ. 0.46 ms
5. Extremely low closed-circuit offset voltages to enable control of small analog signals without distortion

TYPICAL APPLICATIONS

- High-speed inspection machines
- Telephone equipment
- Computers

PhotoMOS

TYPES

	Output rating*		Package	Part No.				Packing quantity	
	Load voltage	Load current		Through hole terminal	Surface-mount terminal		Tube	Tape and reel	
					Tape and reel packing style				
AC/DC dual use	400 V	100 mA	DIP8-pin	Tube packing style	Picked from the 1/2/3-pin side	Picked from the 4/5/6-pin side	1 tube contains: 50 pcs. 1 batch contains: 500 pcs.	1,000 pcs	
				AQW414	AQW414A	AQW414AX	AQW414AZ		

*Indicate the peak AC and DC values.

Note: The surface mount terminal shape indicator "A" and the packing style indicator "X" or "Z" are not marked on the relay.

RATING

1. Absolute maximum ratings (Ambient temperature: 25°C 77°F)

Item		Symbol	AQW414(A)	Remarks
Input	LED forward current	I_F	50 mA	
	LED reverse voltage	V_R	5 V	
	Peak forward current	I_{FP}	1 A	$f = 100 \text{ Hz}$, Duty factor = 0.1%
	Power dissipation	P_{in}	75 mW	
Output	Load voltage (peak AC)	V_L	400 V	
	Continuous load current	I_L	0.1 A (0.13 A)	Peak AC, DC (): in case of using only 1 channel
	Peak load current	I_{peak}	0.3 A	100 ms (1 shot), $V_L = \text{DC}$
	Power dissipation	P_{out}	800 mW	
Total power dissipation		P_T	850 mW	
I/O isolation voltage		V_{iso}	1,500 V AC	
Temperature limits	Operating	T_{opr}	-40°C to +85°C -40°F to +185°F	Non-condensing at low temperatures
	Storage	T_{stag}	-40°C to +100°C -40°F to +212°F	

GU 2 Form B (AQW414)

2. Electrical characteristics (Ambient temperature: 25°C 77°F)

Item		Symbol	AQW414(A)	Condition
Input	LED operate (OFF) current	Typical	0.7 mA	$I_L = \text{Max.}$
		Maximum	3 mA	
	LED reverse (ON) current	Minimum	0.4 mA	$I_L = \text{Max.}$
		Typical	0.64 mA	
LED dropout voltage	Typical	V_F	1.25 V (1.14 V at $I_F = 5 \text{ mA}$)	$I_F = 50 \text{ mA}$
	Maximum		1.5 V	
Output	On resistance	Typical	26 Ω	$I_F = 0 \text{ mA}$ $I_L = \text{Max.}$ Within 1 s on time
		Maximum	50 Ω	
	Off state leakage current	Maximum	I_{Leak}	1 μA
Transfer characteristics	Operate (OFF) time*	Typical	0.46 ms	$I_F = 0 \text{ mA} \rightarrow 5 \text{ mA}$ $I_L = \text{Max.}$
		Maximum	1 ms	
	Reverse (ON) time*	Typical	0.40 ms	$I_F = 5 \text{ mA} \rightarrow 0 \text{ mA}$ $I_L = \text{Max.}$
		Maximum	1 ms	
	I/O capacitance	Typical	C_{iso}	0.8 pF
Maximum		1.5 pF		
Initial I/O isolation resistance	Minimum	R_{iso}	1,000 M Ω	500 V DC

*Operate/Reverse time

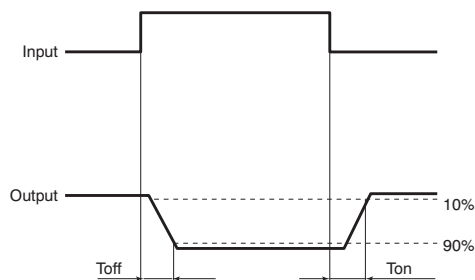

RECOMMENDED OPERATING CONDITIONS

Please obey the following conditions to ensure proper relay operation and resetting.

Item	Symbol	Recommended value	Unit
Input LED current	I_F	5	mA

■ For Dimensions, see page 61.

■ For Schematic and Wiring Diagrams, see page 66.

■ For Cautions for Use, see page 71.

■ These products are not designed for automotive use.

If you are considering to use these products for automotive applications, please contact your local Panasonic technical representative.

For more information, see page 80.

REFERENCE DATA

1. Load current vs. ambient temperature characteristics

Allowable ambient temperature: -40°C to +85°C
-40°F to +185°F

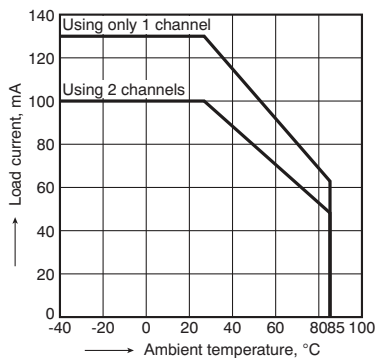

2. On resistance vs. ambient temperature characteristics

Measured portion: between terminals 5 and 6, 7 and 8;
LED current: 0 mA;
Continuous load current: 100 mA (DC)

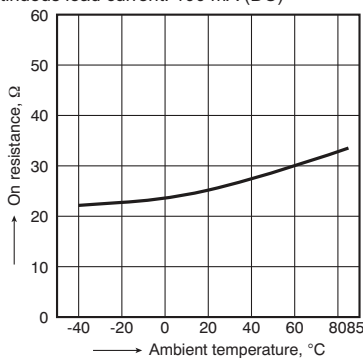

3. Operate (OFF) time vs. ambient temperature characteristics

LED current: 5 mA;
Load voltage: 400 V (DC);
Continuous load current: 100 mA (DC)

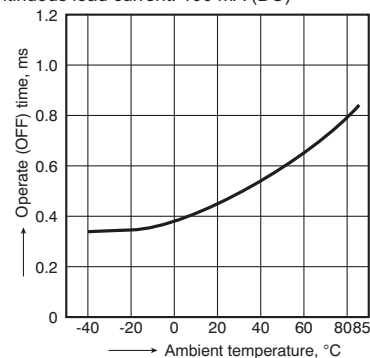

GU 2 Form B (AQW414)

4. Reverse (ON) time vs. ambient temperature characteristics

LED current: 5 mA; Load voltage: 400 V (DC);
Continuous load current: 100 mA (DC)

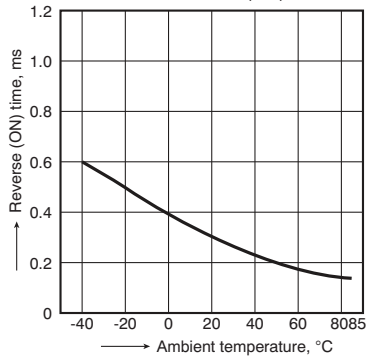

5. LED operate (OFF) current vs. ambient temperature characteristics

Load voltage: 400 V (DC);
Continuous load current: 100 mA (DC)

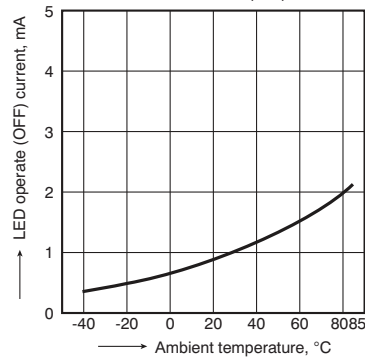

6. LED reverse (ON) current vs. ambient temperature characteristics

Load voltage: 400 V (DC);
Continuous load current: 100 mA (DC)

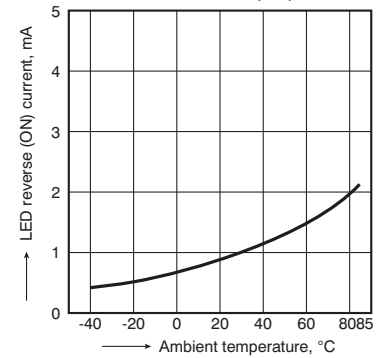

7. LED dropout voltage vs. ambient temperature characteristics

LED current: 5 to 50 mA

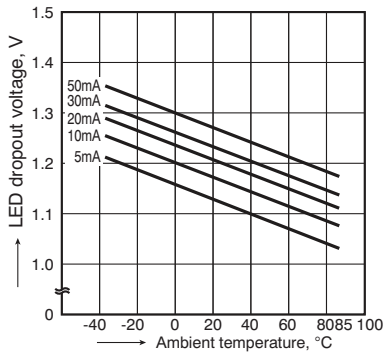

8. Current vs. voltage characteristics of output at MOS portion

Measured portion: between terminals 5 and 6, 7 and 8;
Ambient temperature: 25°C 77°F

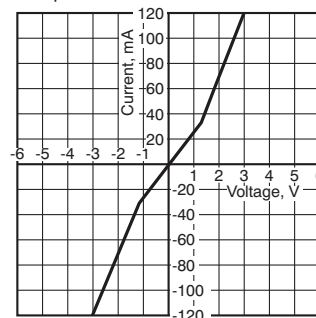

9. Off state leakage current vs. load voltage characteristics

Measured portion: between terminals 5 and 6, 7 and 8;
Ambient temperature: 25°C 77°F

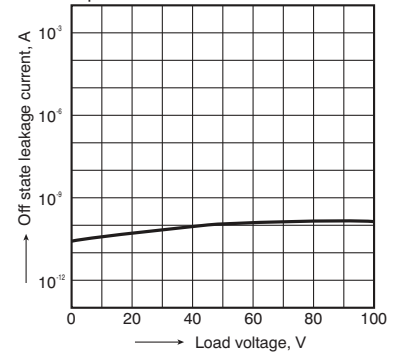

10. Operate (OFF) time vs. LED forward current characteristics

Measured portion: between terminals 5 and 6, 7 and 8;
Load voltage: 400 V (DC);
Continuous load current: 100 mA (DC);
Ambient temperature: 25°C 77°F

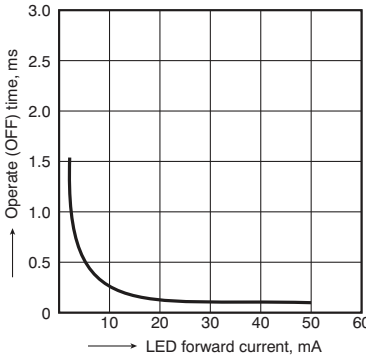

11. Reverse (ON) time vs. LED forward current characteristics

Measured portion: between terminals 5 and 6, 7 and 8;
Load voltage: 400 V (DC);
Continuous load current: 100 mA (DC);
Ambient temperature: 25°C 77°F

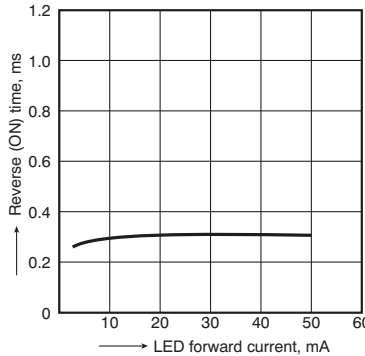

12. Output capacitance vs. applied voltage characteristics

Measured portion: between terminals 5 and 6, 7 and 8;
Frequency: 1 MHz;
Ambient temperature: 25°C 77°F

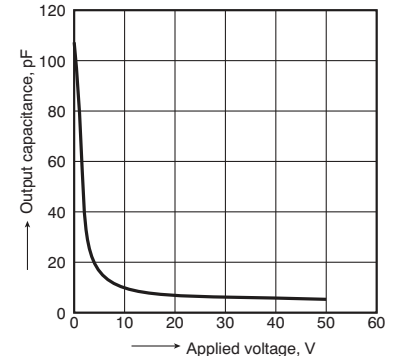

Panasonic

ideas for life



Both NO and NC contacts
incorporated in a small
SOP8-pin package

PhotoMOS[®]
GU SOP Form A & B
(AQW610S)

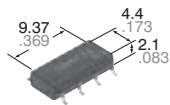

CAD Data

mm inch

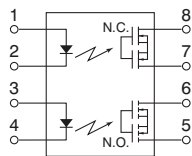

FEATURES

1. Normally open and normally closed contacts in a SOP package
The device comes in a miniature SOP measuring (W) 4.4 × (L) 9.37 × (H) 2.1 mm (W) .173× (L) .369× (H) .083 inch — approx. 38% of the volume and 66% of the footprint size of DIP type.

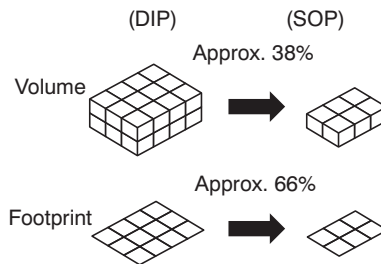

2. 60V type couples high capacity (0.45A) with low on-resistance (typ. 1Ω) (AQW612S).
3. Applicable for 1 Form A 1 Form B use as well as two independent 1 Form A and 1 Form B use

4. Controls low-level analog signals
PhotoMOS relays feature extremely low closed-circuit offset voltage to enable control of low-level analog signals without distortion
5. Low-level off-state leakage current of max. 1 μA

TYPICAL APPLICATIONS

- Power supply
- Measuring equipment
- Security equipment
- Telephone equipment
- Computer input machines
- Industrial robots
- High-speed inspection machines

TYPES

	Output rating*		Package	Part No.			Packing quantity	
	Load voltage	Load current		Tube packing style	Tape and reel packing style		Tube	Tape and reel
					Picked from the 1/2/3/4-pin side	Picked from the 5/6/7/8-pin side		
AC/DC dual use	60V	450mA	SOP8-pin	AQW612S	AQW612SX	AQW612SZ	1 tube contains: 50 pcs. 1 batch contains: 1,000 pcs.	1,000 pcs.
	350V	100mA		AQW610S	AQW610SX	AQW610SZ		

* Indicate the peak AC and DC values.

Note: The packing style indicator "X" or "Z" are not marked on the relay.

RATING

1. Absolute maximum ratings (Ambient temperature: 25°C 77°F)

Item		Symbol	AQW612S	AQW610S	Remarks
Input	LED forward current	I _F	50 mA		
	LED reverse voltage	V _R	5 V		
	Peak forward current	I _{FP}	1 A		f = 100 Hz, Duty factor = 0.1%
	Power dissipation	P _{in}	75 mW		
Output	Load voltage (peak AC)	V _L	60 V	350 V	
	Continuous load current	I _L	0.45 A (0.55 A)	0.1 A (0.13 A)	Peak AC, DC (): in case of using only 1a or 1b, 1 channel
	Peak load current	I _{peak}	1.5 A	0.3 A	100 ms (1 shot), V _L = DC
	Power dissipation	P _{out}	600 mW		
Total power dissipation		P _T	650 mW		
I/O isolation voltage		V _{iso}	1,500 V AC		
Temperature limits	Operating	T _{opr}	-40°C to +85°C -40°F to +185°F		Non-condensing at low temperatures
	Storage	T _{stg}	-40°C to +100°C -40°F to +212°F		

GU SOP Form A & B (AQW61OS)

2. Electrical characteristics (Ambient temperature: 25°C 77°F)

Item			Symbol	AQW612S	AQW610S	Condition
Input	LED operate current	Typical	I_{Fon}	0.9 mA		$I_L = \text{Max.}$
		Maximum		3 mA		
	LED reverse current	Minimum	I_{Foff}	0.4 mA		$I_L = \text{Max.}$
		Typical		0.8 mA		
LED dropout voltage	Typical	V_F	1.25 V (1.14 V at $I_F = 5 \text{ mA}$)		$I_F = 50 \text{ mA}$	
	Maximum		1.5 V			
Output	On resistance	Typical	R_{on}	1 Ω	18 Ω	$I_F = 5 \text{ mA (N.O.)}$ $I_F = 0 \text{ mA (N.C.)}$ $I_L = \text{Max.}$ Within 1 s on time
		Maximum		2.5 Ω	25 Ω	
	Off state leakage current	Maximum	I_{Leak}	1 μA		$I_F = 0 \text{ mA (N.O.)}$ $I_F = 5 \text{ mA (N.C.)}$ $V_L = \text{Max.}$
Transfer characteristics	Operate time*	Typical	$T_{on} \text{ (N.O.)}$	0.65 ms (N.O.), 0.9 ms (N.C.)		$I_F = 0 \text{ mA} \rightarrow 5 \text{ mA}$ $I_L = \text{Max.}$
		Maximum		$T_{off} \text{ (N.C.)}$	3.0 ms	
	Reverse time*	Typical	$T_{off} \text{ (N.O.)}$	0.08 ms (N.O.), 0.2 ms (N.C.)		$I_F = 5 \text{ mA} \rightarrow 0 \text{ mA}$ $I_L = \text{Max.}$
		Maximum		$T_{on} \text{ (N.C.)}$	1.0 ms	
	I/O capacitance	Typical	C_{iso}	0.8 pF		$f = 1 \text{ MHz}$ $V_B = 0 \text{ V}$
Maximum	1.5 pF					
Initial I/O isolation resistance	Minimum	R_{iso}	1,000 M Ω		500 V DC	

*Operate/Reverse time

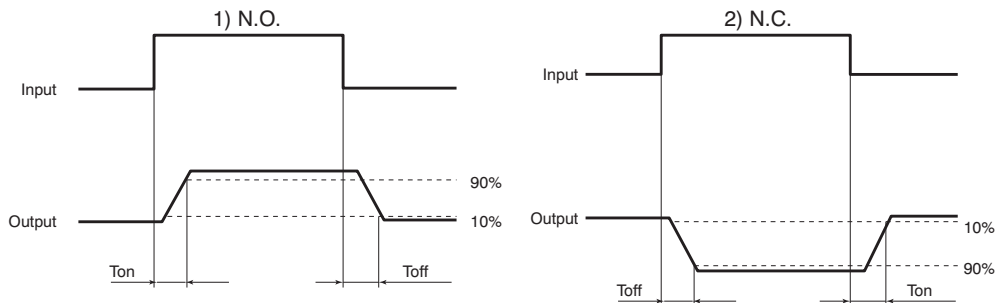

RECOMMENDED OPERATING CONDITIONS

Please obey the following conditions to ensure proper relay operation and resetting.

Item	Symbol	Recommended value	Unit
Input LED current	I_F	5	mA

■ For Dimensions, see page 62.

■ For Schematic and Wiring Diagrams, see page 66.

■ For Cautions for Use, see page 71.

■ These products are not designed for automotive use.

If you are considering to use these products for automotive applications, please contact your local Panasonic technical representative.

For more information, see page 80.

REFERENCE DATA

13. Load current vs. ambient temperature characteristics

Allowable ambient temperature: -40°C to $+85^\circ\text{C}$
 -40°F to $+185^\circ\text{F}$

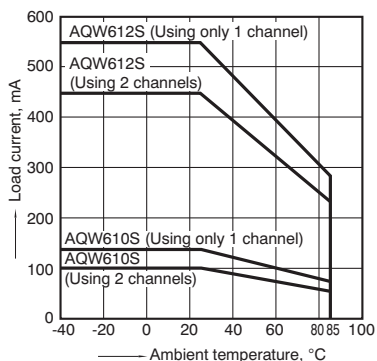

14. On resistance vs. ambient temperature characteristics

Measured portion: between terminals 5 and 6, 7 and 8; LED current: 5 mA; Load voltage: Max. (DC); Continuous load current: Max. (DC)

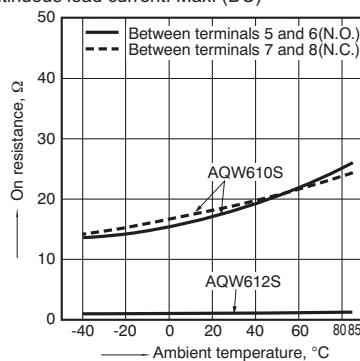

15. Operate time vs. ambient temperature characteristics

LED current: 5 mA; Load voltage: Max. (DC); Continuous load current: Max. (DC)

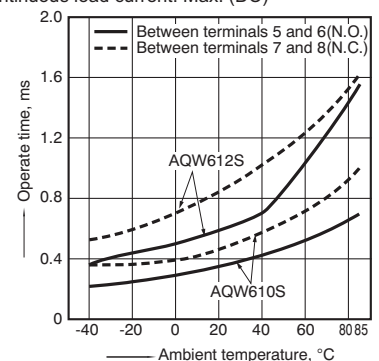

GU SOP Form A & B (AQW610S)

16.Reverse time vs. ambient temperature characteristics

LED current: 5 mA; Load voltage: Max. (DC); Continuous load current: Max. (DC)

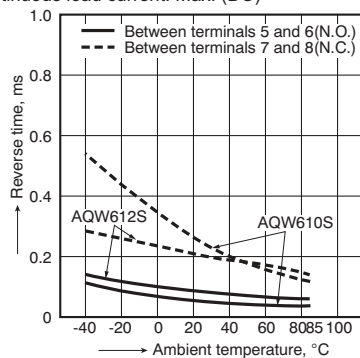

17.LED operate current vs. ambient temperature characteristics

Load voltage: Max. (DC); Continuous load current: Max. (DC)

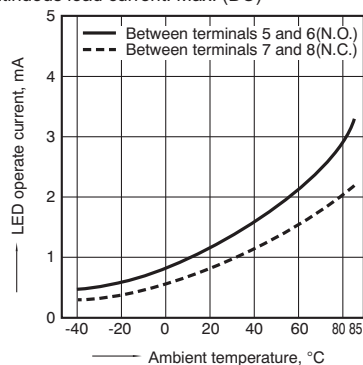

18.LED reverse current vs. ambient temperature characteristics

Load voltage: Max. (DC); Continuous load current: Max. (DC)

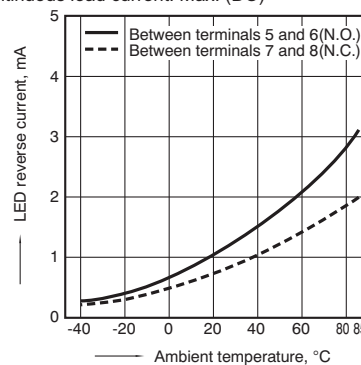

19.LED dropout voltage vs. ambient temperature characteristics

LED current: 5 to 50 mA

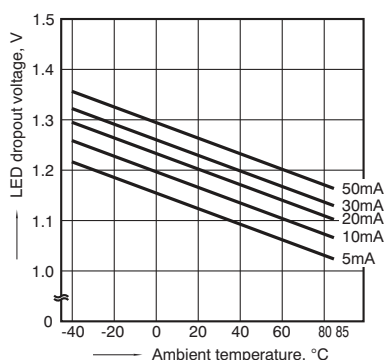

20-(1). Current vs. voltage characteristics of output at MOS portion

Measured portion: between terminals 5 and 6, 7 and 8; Ambient temperature: 25°C 77°F

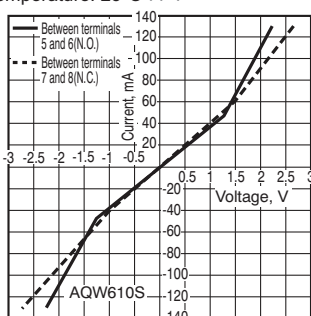

8-(2). Current vs. voltage characteristics of output at MOS portion

Measured portion: between terminals 5 and 6, 7 and 8; Ambient temperature: 25°C 77°F

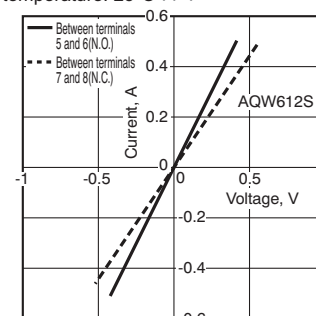

21-(1). Off state leakage current vs. load voltage characteristics

Measured portion: between terminals 5 and 6, 7 and 8; Ambient temperature: 25°C 77°F

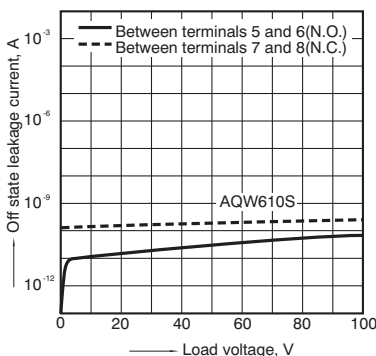

9-(2). Off state leakage current vs. load voltage characteristics

Measured portion: between terminals 5 and 6, 7 and 8; Ambient temperature: 25°C 77°F

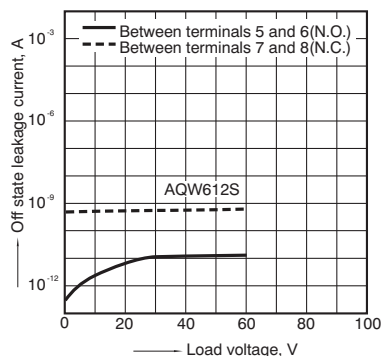

22. Operate time vs. LED forward current characteristics

Measured portion: between terminals 5 and 6, 7 and 8; Load voltage: Max. (DC); Continuous load current: Max. (DC); Ambient temperature: 25°C 77°F

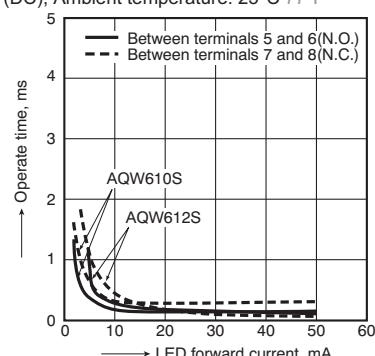

23.Reverse time vs. LED forward current characteristics

Measured portion: between terminals 5 and 6, 7 and 8; Load voltage: Max. (DC); Continuous load current: Max. (DC); Ambient temperature: 25°C 77°F

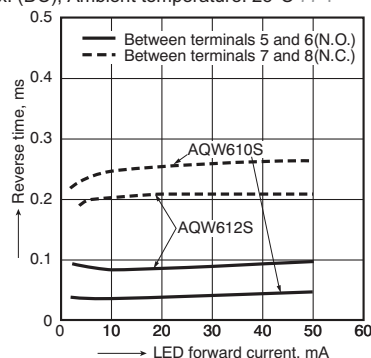

24.Output capacitance vs. applied voltage characteristics

Measured portion: between terminals 5 and 6, 7 and 8; Frequency: 1 MHz; Ambient temperature: 25°C 77°F

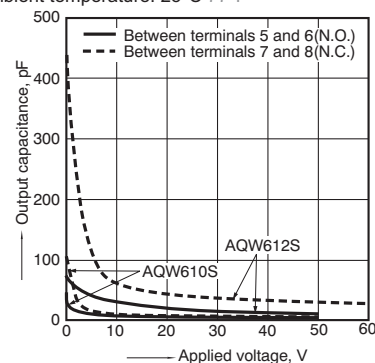

Panasonic

ideas for life



Both NO and NC contacts
incorporated in a
DIP8-pin package

PhotoMOS[®]
GU Form A & B
(AQW614)

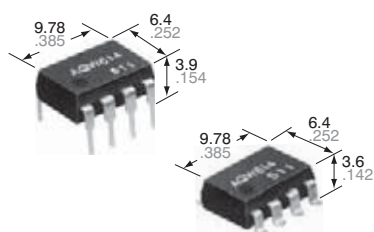

CAD Data

mm inch

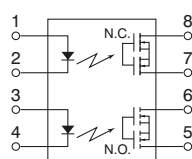

FEATURES

1. Approx. 1/2 the space compared with the mounting of a set of 1 Form A and 1 Form B PhotoMOS relays
2. Applicable for 1 Form A 1 Form B use as well as two independent 1 Form A and 1 Form B use
3. Controls load currents up to 0.13 A with 5 mA input current
4. Extremely low closed-circuit offset voltages to enable control of small analog signals without distortion
5. Stable on-resistance

TYPICAL APPLICATIONS

- High-speed inspection machines
- Telephone equipment
- Computers
- Sensing equipment

PhotoMOS

TYPES

	Output rating*		Package	Part No.				Packing quantity	
	Load voltage	Load current		Through hole terminal	Surface-mount terminal		Tube	Tape and reel	
					Tape and reel packing style				
AC/DC dual use	400 V	100 mA	DIP8-pin	Tube packing style	Picked from the 1/2/3-pin side	Picked from the 4/5/6-pin side	1 tube contains: 50 pcs. 1 batch contains: 500 pcs.	1,000 pcs.	
				AQW614	AQW614A	AQW614AX	AQW614AZ		

*Indicate the peak AC and DC values.

Note: The surface mount terminal shape indicator "A" and the packing style indicator "X" or "Z" are not marked on the relay.

RATING

1. Absolute maximum ratings (Ambient temperature: 25°C 77°F)

Item		Symbol	AQW614(A)	Remarks
Input	LED forward current	I_F	50 mA	
	LED reverse voltage	V_R	5 V	
	Peak forward current	I_{FP}	1 A	f = 100 Hz, Duty factor = 0.1%
	Power dissipation	P_{in}	75 mW	
Output	Load voltage (peak AC)	V_L	400 V	
	Continuous load current	I_L	0.1 A (0.13 A)	Peak AC, DC () : in case of using only 1a or 1b, 1 channel
	Peak load current	I_{peak}	0.3 A	100 ms (1 shot), $V_L = DC$
	Power dissipation	P_{out}	800 mW	
Total power dissipation		P_T	850 mW	
I/O isolation voltage		V_{iso}	1,500 V AC	Between input and output/between contact sets
Temperature limits	Operating	T_{opr}	-40°C to +85°C -40°F to +185°F	Non-condensing at low temperatures
	Storage	T_{stg}	-40°C to +100°C -40°F to +212°F	

GU Form A & B (AQW614)

2. Electrical characteristics (Ambient temperature: 25°C 77°F)

Item		Symbol	AQW614(A)	Condition	
Input	LED operate current	Typical	I_{Fon} (N.O.) 0.9 mA	$I_L = 100$ mA	
		Maximum	I_{Foff} (N.C.) 3 mA		
	LED reverse current	Minimum	I_{Foff} (N.O.) 0.4 mA	$I_L = 100$ mA	
		Typical	I_{Fon} (N.C.) 0.8 mA		
LED dropout voltage	Typical	V_F	1.25 V (1.14 V at $I_F = 5$ mA)	$I_F = 50$ mA	
	Maximum		1.5 V		
Output	On resistance	Typical	27 Ω	$I_F = 5$ mA (N.O.) $I_F = 0$ mA (N.C.) $I_L = 100$ mA within 1 s on time	
		Maximum	50 Ω		
	Off state leakage current	Maximum	I_{Leak}	1 μ A	$I_F = 0$ mA (N.O.) $I_F = 5$ mA (N.C.) $V_L = 400$ V
Transfer characteristics	Operate time*	Typical	T_{on} (N.O.) 0.28 ms (N.O.) 0.43 ms (N.C.)	$I_F = 0$ mA \rightarrow 5 mA $I_L = 100$ mA	
		Maximum	T_{off} (N.C.) 1 ms		
	Reverse time*	Typical	T_{off} (N.O.) 0.04 ms (N.O.) 0.3 ms (N.C.)	$I_F = 5$ mA \rightarrow 0 mA $I_L = 100$ mA	
		Maximum	T_{on} (N.C.) 1 ms		
	I/O capacitance	Typical	C_{iso}	0.8 pF	$f = 1$ MHz $V_B = 0$ V
		Maximum		1.5 pF	
Initial I/O isolation resistance	Minimum	R_{iso}	1,000 M Ω	500 V DC	

*Operate/Reverse time

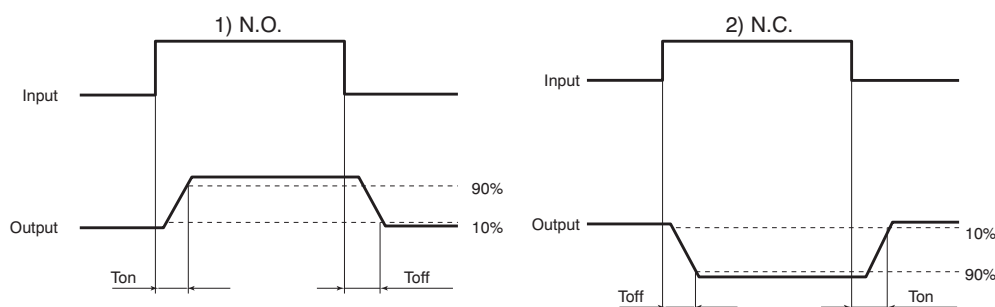

RECOMMENDED OPERATING CONDITIONS

Please obey the following conditions to ensure proper relay operation and resetting.

Item	Symbol	Recommended value	Unit
Input LED current	I_F	5	mA

■ For Dimensions, see page 61.

■ For Schematic and Wiring Diagrams, see page 66.

■ For Cautions for Use, see page 71.

■ These products are not designed for automotive use.

If you are considering to use these products for automotive applications, please contact your local Panasonic technical representative.

For more information, see page 80.

REFERENCE DATA

1. Load current vs. ambient temperature characteristics

Allowable ambient temperature: -40°C to $+85^\circ\text{C}$
 -40°F to $+185^\circ\text{F}$

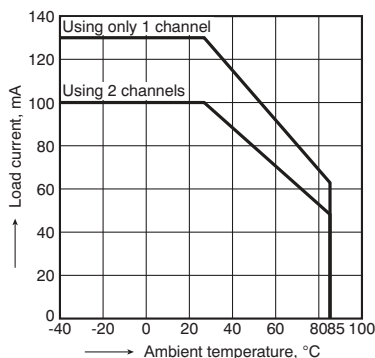

2. On resistance vs. ambient temperature characteristics

Measured portion: between terminals 5 and 6, 7 and 8;
LED current: 5 mA; Load voltage: 400 V (DC);
Continuous load current: 100 mA (DC)

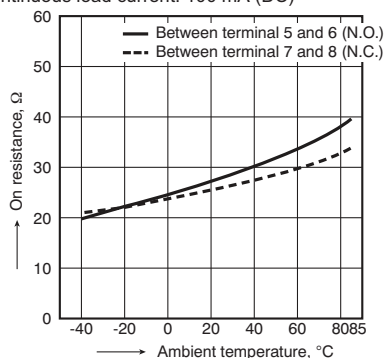

3. Operate time vs. ambient temperature characteristics

LED current: 5 mA;
Load voltage: 400 V (DC);
Continuous load current: 100 mA (DC)

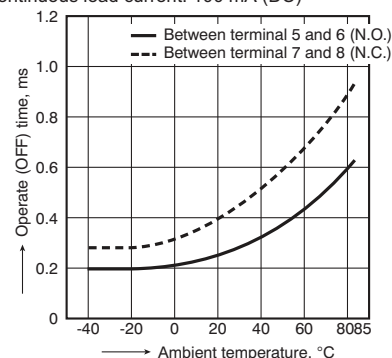

GU Form A & B (AQW614)

PhotoMOS

4. Reverse time vs. ambient temperature characteristics

LED current: 5 mA; Load voltage: 400 V (DC);
Continuous load current: 100 mA (DC)

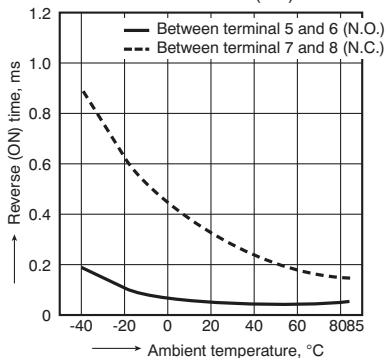

5. LED operate current vs. ambient temperature characteristics

Load voltage: 400 V (DC);
Continuous load current: 100 mA (DC)

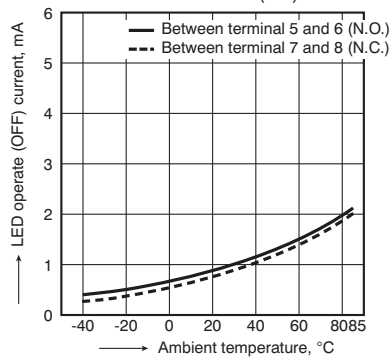

6. LED reverse current vs. ambient temperature characteristics

Load voltage: 400 V (DC);
Continuous load current: 100 mA (DC)

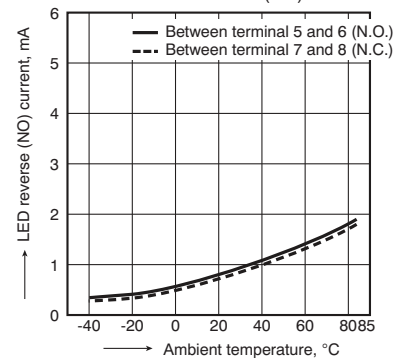

7. LED dropout voltage vs. ambient temperature characteristics

LED current: 5 to 50 mA

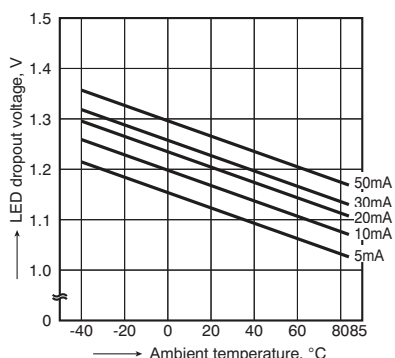

8. Current vs. voltage characteristics of output at MOS portion

Measured portion: between terminals 5 and 6, 7 and 8;
Ambient temperature: 25°C 77°F

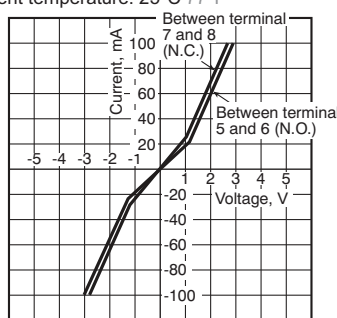

9. Off state leakage current vs. load voltage characteristics

Measured portion: between terminals 5 and 6, 7 and 8;
Ambient temperature: 25°C 77°F

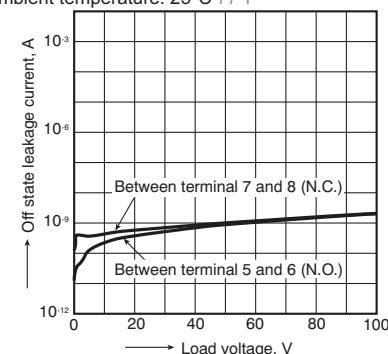

10. Operate time vs. LED forward current characteristics

Measured portion: between terminals 5 and 6, 7 and 8;
Load voltage: 400 V (DC); Continuous load current:
100 mA (DC); Ambient temperature: 25°C 77°F

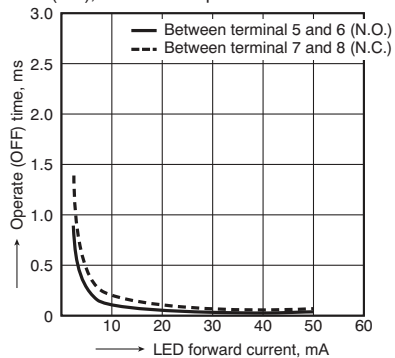

11. Reverse time vs. LED forward current characteristics

Measured portion: between terminals 5 and 6, 7 and 8;
Load voltage: 400 V (DC); Continuous load current:
100 mA (DC); Ambient temperature: 25°C 77°F

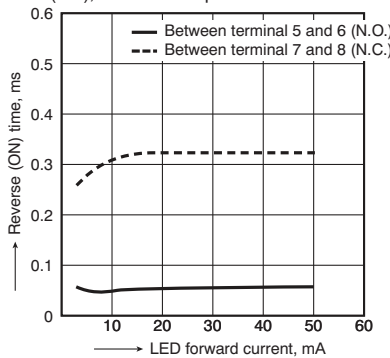

12. Output capacitance vs. applied voltage characteristics

Measured portion: between terminals 5 and 6, 7 and 8;
Frequency: 1 MHz;
Ambient temperature: 25°C 77°F

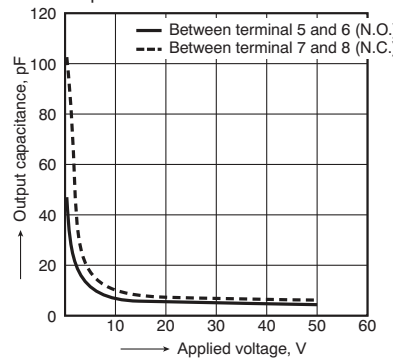

Panasonic

ideas for life



Small SOP4-pin type with
short circuit protecting
(Latch type)

PhotoMOS[®]
GU SOP 1 Form A
Short Circuit Protection (AQY210KS)

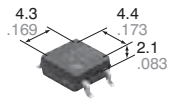

CAD Data

mm inch

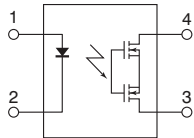

FEATURES

- 1. Short circuit protection (Latch type)**
When the output current exceeds a fixed amount, it is cut and the off state is maintained. The relay can be restored by turning off the input current and then turning it back on.
- 2. Miniature SOP4-pin package**
- 3. Controls low-level analog signals**
- 4. Low-level off state leakage current**

TYPICAL APPLICATIONS

- Modem and telephone equipment
- Measuring and testing equipment
- Security equipment
- Industrial equipment
- Traffic signal control

TYPES

	Output rating*		Package	Part No.			Packing quantity	
	Load voltage	Load current		Tube packing style	Tape and reel packing style		Tube	Tape and reel
					Picked from the 1/2-pin side)	Picked from the 3/4-pin side)		
AC/DC dual use	350V	120mA	SOP4-pin	AQY210KS	AQY210KSX	AQY210KSZ	1 tube contains: 100 pcs. 1 batch contains: 2,000 pcs.	1,000 pcs.

* Indicate the peak AC and DC values.

Note: For space reasons, only "210K" is marked on the product. The three initial letters of the part number "AQY", the surface mount terminal shape indicator "S" and the packing style indicator "X" or "Z" are not marked on the relay.

RATING

1. Absolute maximum ratings (Ambient temperature: 25°C 77°F)

Item		Symbol	AQY210KS	Remarks
Input	LED forward current	I_F	50 mA	
	LED reverse voltage	V_R	5 V	
	Peak forward current	I_{FP}	1 A	f = 100 Hz, Duty factor = 0.1%
	Power dissipation	P_{in}	75 mW	
Output	Load voltage (peak AC)	V_L	350 V	
	Continuous load current	I_L	0.12 A	Peak AC, DC
	Power dissipation	P_{out}	400 mW	
Total power dissipation		P_T	450 mW	
I/O isolation voltage		V_{iso}	1,500 V AC	
Temperature limits	Operating	T_{opr}	-40°C to +85°C -40°F to +185°F	Non-condensing at low temperatures
	Storage	T_{stg}	-40°C to +100°C -40°F to +212°F	

GU SOP 1 Form A Short Circuit Protection (AQY210KS)

2. Electrical characteristics (Ambient temperature: 25°C 77°F)

Item			Symbol	AQY210KS	Condition	
Input	LED operate current	Typical	I_{Fon}	1.1 mA	$I_L = \text{Max.}$	
		Maximum		3.0 mA		
	LED turn off current	Minimum	I_{Foff}	0.3 mA	$I_L = \text{Max.}$	
		Typical		1.0 mA		
LED dropout voltage	Typical	V_F	1.32 V (1.13 V at $I_F = 5 \text{ mA}$)			
	Maximum		1.5 V	$I_F = 50 \text{ mA}$		
Output	On resistance	Typical	R_{on}	23.5Ω	$I_F = 5 \text{ mA}$ $I_L = 120 \text{ mA}$ Within 1 s on time	
		Maximum		35Ω		
	Off state leakage current		Maximum	I_{Leak}	1μA	$I_F = 0 \text{ mA}$ $V_L = 350 \text{ V}$
	Over current protection	Cut off current	Minimum	I_{shut}	160 mA	$I_F = 5 \text{ mA}$ Within 20ms on time
			Typical		200 mA	
			Maximum		240 mA	
Detection time		Typical	T_{shut}	50μs	$I_F = 5 \text{ mA}$ $V_L = 350 \text{ V}$ DC short circuit	
Transfer characteristics	Turn on time*		Typical	T_{on}	0.7 ms	$I_F = 5 \text{ mA}$ $I_L = \text{Max.}$
					Maximum	
	Turn off time*		Typical	T_{off}	0.07 ms	$I_F = 5 \text{ mA}$ $I_L = \text{Max.}$
					Maximum	
	I/O capacitance		Typical	C_{iso}	0.8 pF	$f = 1 \text{ MHz}$ $V_E = 0 \text{ V}$
			Maximum		1.5 pF	
Initial I/O isolation resistance		Minimum	R_{iso}	1,000 MΩ	500 V DC	

*Turn on/Turn off time

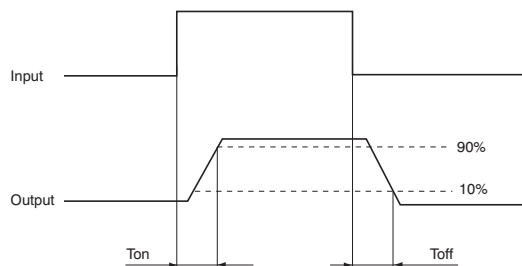

RECOMMENDED OPERATING CONDITIONS

Please obey the following conditions to ensure proper relay operation and resetting.

Item	Symbol	Recommended value	Unit
Input LED current	I_F	5	mA

■ For Dimensions, see page 62.

■ For Schematic and Wiring Diagrams, see page 64.

■ For Cautions for Use, see page 71.

■ These products are not designed for automotive use.

If you are considering to use these products for automotive applications, please contact your local Panasonic technical representative.

For more information, see page 80.

GU SOP 1 Form A Short Circuit Protection (AQY210KS)

REFERENCE DATA

1. Load current vs. ambient temperature characteristics

Allowable ambient temperature: -40°C to $+85^{\circ}\text{C}$
 -40°F to $+185^{\circ}\text{F}$

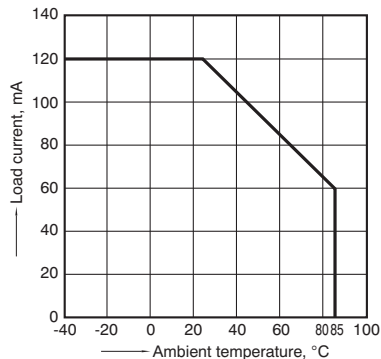

2. On resistance vs. ambient temperature characteristics

Measured portion: between terminals 3 and 4;
 LED current: 5 mA; Load current: Max.(DC)

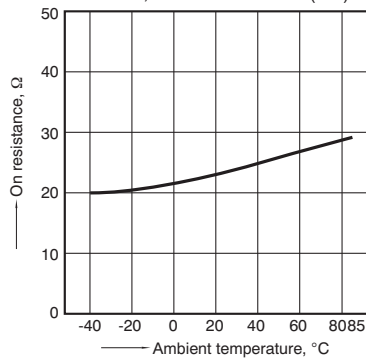

3. Turn on time vs. ambient temperature characteristics

LED current: 5 mA;
 Continuous load current: Max.(DC)

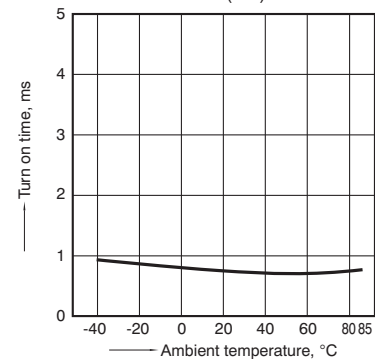

4. Turn off time vs. ambient temperature characteristics

LED current: 5 mA;
 Continuous load current: Max.(DC)

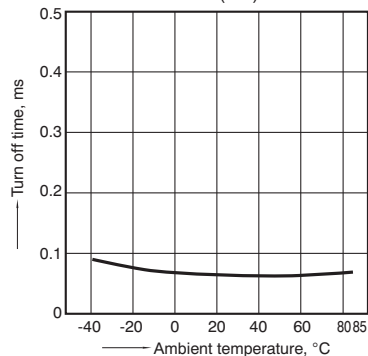

5. LED operate current vs. ambient temperature characteristics

Continuous load current: Max.(DC)

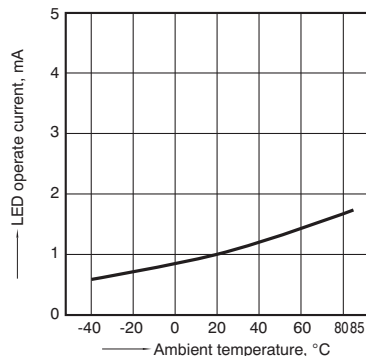

6. LED turn off current vs. ambient temperature characteristics

Continuous load current: Max.(DC)

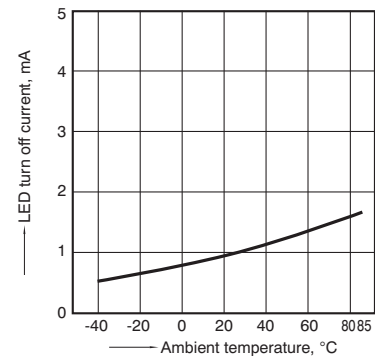

7. LED dropout voltage vs. ambient temperature characteristics

LED current: 5 to 50 mA

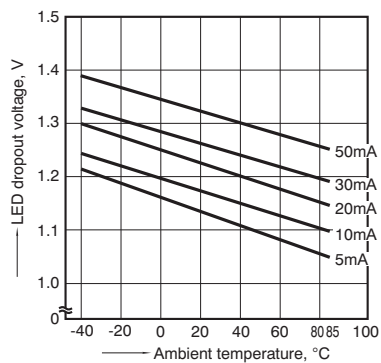

8. Current vs. voltage characteristics of output at MOS portion

Measured portion: between terminals 3 and 4;
 Ambient temperature: 25°C 77°F

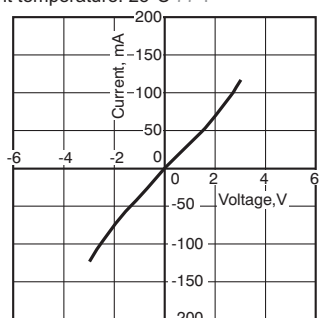

9. Off state leakage current vs. load voltage characteristics

Measured portion: between terminals 3 and 4;
 Ambient temperature: 25°C 77°F

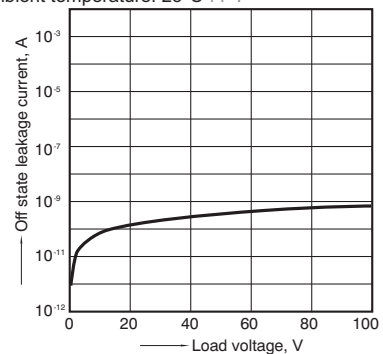

GU SOP 1 Form A Short Circuit Protection (AQY210KS)

10. Turn on time vs. LED forward current characteristics

Measured portion: between terminals 3 and 4; Load voltage: Max.(DC); Continuous load current:Max.(DC); Ambient temperature: 25°C 77°F

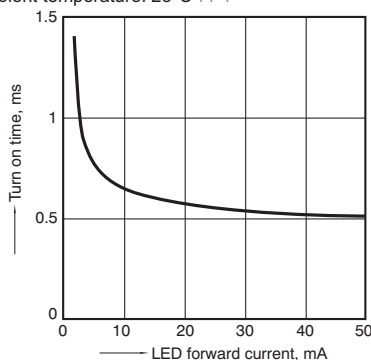

11. Turn off time vs. LED forward current characteristics

Measured portion: between terminals 3 and 4; Load voltage: Max.(DC); Continuous load current:Max.(DC); Ambient temperature: 25°C 77°F

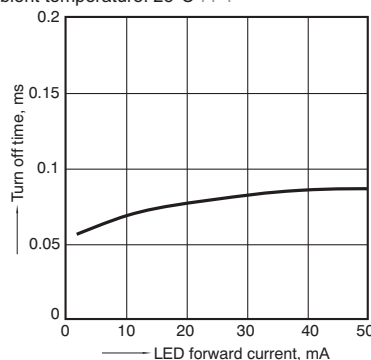

12. Output capacitance vs. applied voltage characteristics

Measured portion: between terminals 3 and 4; Frequency: 1 MHz; Ambient temperature: 25°C 77°F

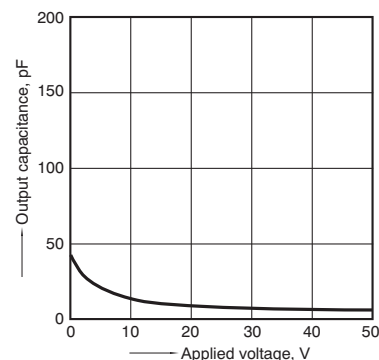

13. Cut off current vs. ambient temperature characteristics

Measured portion: between terminals 3 and 4; LED current: 5 mA, within 20ms on time

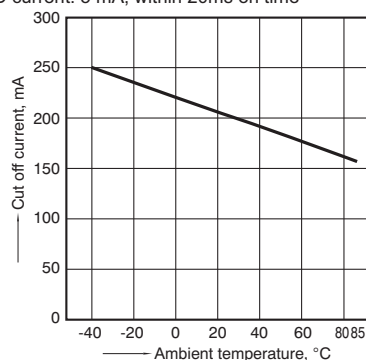

14. Detection time vs. ambient temperature characteristics

Measured portion: between terminals 3 and 4; LED current: 5 mA; Load voltage: Max.(DC);

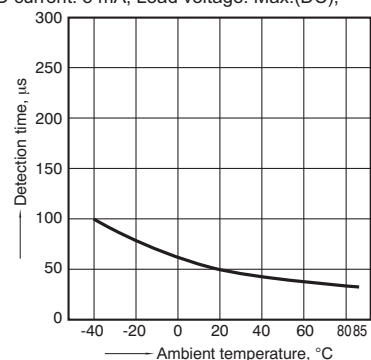

GU SOP 1 Form A Short Circuit Protection (AQY210KS)

What is short circuit protection latch type?

When the load current exceeds specifications, the short circuit protection function kicks in and completely cuts off the load current, thus turning off the relay.

The short circuit protection inside the PhotoMOS relay instantaneously (typ. 50 μ s) and completely cuts off the load current.

This protects any circuits that follow the PhotoMOS relay from excess current.

There is almost no heating of the PhotoMOS relay, which prevents it from becoming damaged. To restore the function of the relay turn off the input current and then turn it back on.

In order to operate the short circuit protection function, ensure that the input current is at least $I_F = 5$ mA.

Output voltage and output current characteristics

V-I characteristics of PhotoMOS relay with short circuit protection circuit

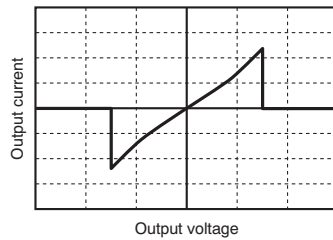

Operation chart

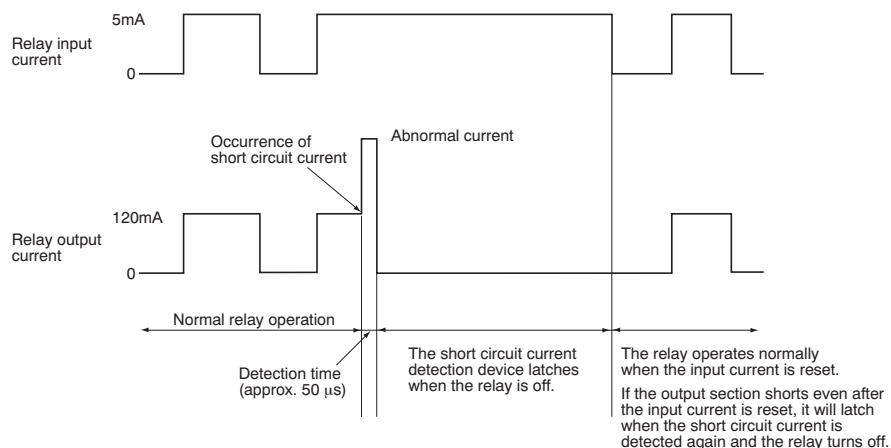

Panasonic

ideas for life



**Short circuit protection
(Non-latch type)
only for DC load**

**PhotoMOS[®]
GU 1 Form A**
Short Circuit Protection (AQV112KL)

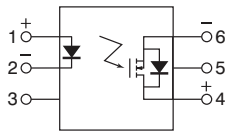
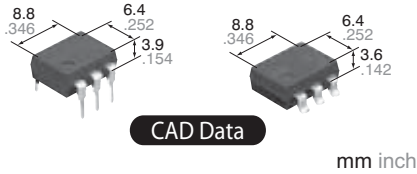

FEATURES

1. Protects Circuit from excess current

The short circuit protection function prevents the continued flow of short current. After short current is detected, load current is monitored, and if the load returns to normal, the relay returns to normal operation.

2. No need for fuses, polyswitches, or other protectors

The built-in short circuit protection function eliminates the need for overcurrent protectors, reducing mounting costs and space requirements.

3. High capacity

Can control up to 0.5A (60V DC) load current.

TYPICAL APPLICATIONS

- Industrial equipment
- Traffic signal control
- Security equipment

PhotoMOS

TYPES

	Output rating*		Package	Part No.				Packing quantity	
				Through hole terminal	Surface-mount terminal		Tube	Tape and reel	
	Load voltage	Load current			Tube packing style	Tape and reel packing style			
DC only	60 V	500 mA	DIP6-pin	AQV112KL	AQV112KLA	AQV112KLAX	AQV112KLAZ	1 tube contains: 50 pcs. 1 batch contains: 500 pcs.	1,000 pcs.

*Indicate the DC values.

Note: The surface mount terminal shape indicator "A" and the packing style indicator "X" or "Z" are not marked on the relay.

RATING

1. Absolute maximum ratings (Ambient temperature: 25°C 77°F)

Item		Symbol	AQV112KL(A)	Remarks
Input	LED forward current	I_F	50 mA	
	LED reverse voltage	V_R	5 V	
	Peak forward current	I_{FP}	1 A	$f = 100 \text{ Hz}$, Duty factor = 0.1%
	Power dissipation	P_{in}	75 mW	
Output	Load voltage (peak AC)	V_L	7 to 60V	
	Continuous load current	I_L	0.5 A	Peak AC, DC
	Power dissipation	P_{out}	500 mW	
Total power dissipation		P_T	550 mW	
I/O isolation voltage		V_{iso}	1,500 V AC	
Temperature limits	Operating	T_{opr}	-40°C to +85°C -40°F to +185°F	Non-condensing at low temperatures
	Storage	T_{stg}	-40°C to +100°C -40°F to +212°F	

GU 1 Form A Short Circuit Protection (AQV112KL)

2. Electrical characteristics (Ambient temperature: 25°C 77°F)

Item		Symbol	AQV112KL(A)	Condition
Input	LED operate current	Typical	0.8 mA	$I_L = 100\text{mA}$
		Maximum	10 mA	
	LED turn off current	Minimum	0.3 mA	$I_L = 100\text{mA}$
		Typical	0.7 mA	
LED dropout voltage	Typical	V_F	1.35 V (1.17 V at $I_F = 10\text{ mA}$)	$I_F = 50\text{ mA}$
	Maximum		1.5 V	
Output	On resistance	Typical	0.55 Ω	$I_F = 10\text{ mA}$ $I_L = \text{Max.}$
		Maximum	2.0 Ω	
	Load short circuit detection voltage	Typical	5 V	$I_F = 10\text{ mA}$
		Maximum	7 V	
	Off state leakage current	Maximum	I_{Leak}	1 μA
Transfer characteristics	Turn on time*	Typical	2.0 ms	$I_F = 10\text{ mA}$ $I_L = 100\text{ mA}$ $V_L = 10\text{ V}$
		Maximum	5.0 ms	
	Turn off time*	Typical	0.1 ms	$I_F = 10\text{ mA}$ $I_L = 100\text{ mA}$ $V_L = 10\text{ V}$
		Maximum	1.0 ms	
	I/O capacitance	Typical	C_{iso}	0.8 pF
Maximum		1.5 pF		
Initial I/O isolation resistance	Minimum	R_{iso}	1,000 M Ω	500 V DC

*Turn on/Turn off time

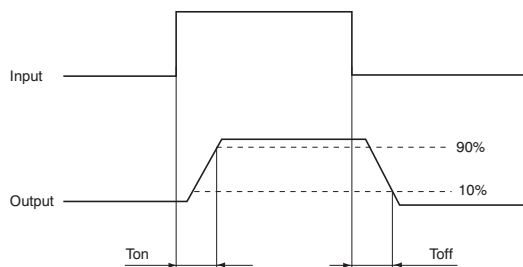

RECOMMENDED OPERATING CONDITIONS

Please obey the following conditions to ensure proper relay operation and resetting.

Item	Symbol	Recommended value	Unit
Input LED current	I_F	10	mA

■ For Dimensions, see page 60.

■ For Schematic and Wiring Diagrams, see page 64.

■ For Cautions for Use, see page 71.

■ These products are not designed for automotive use.

If you are considering to use these products for automotive applications, please contact your local Panasonic technical representative.

For more information, see page 80.

GU 1 Form A Short Circuit Protection (AQV112KL)

REFERENCE DATA

1. Load current vs. ambient temperature characteristics

Allowable ambient temperature: -40°C to $+85^{\circ}\text{C}$
 -40°F to $+185^{\circ}\text{F}$

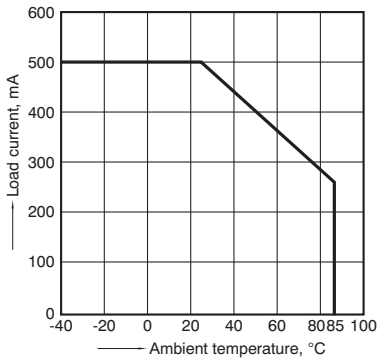

2. On resistance vs. ambient temperature characteristics

Measured portion: between terminals 4 and 6;
 LED current: 10 mA; Load current: Max.(DC)

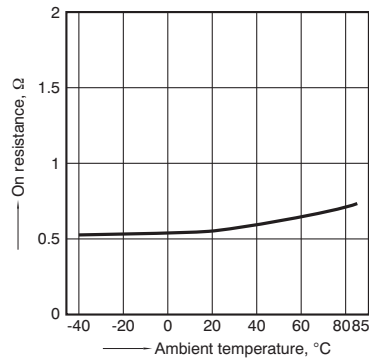

3. Turn on time vs. ambient temperature characteristics

Measured portion: between terminals 4 and 6;
 LED current: 10 mA; Load voltage: 10V (DC);
 Load current: 100 mA

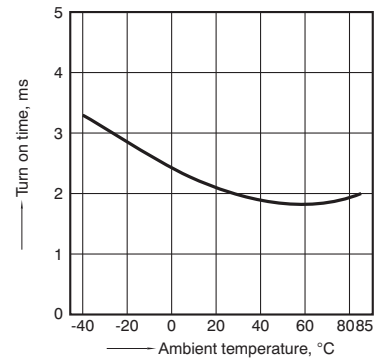

4. Turn off time vs. ambient temperature characteristics

Measured portion: between terminals 4 and 6;
 LED current: 10 mA; Load voltage: 10 V (DC);
 Load current: 100 mA (DC)

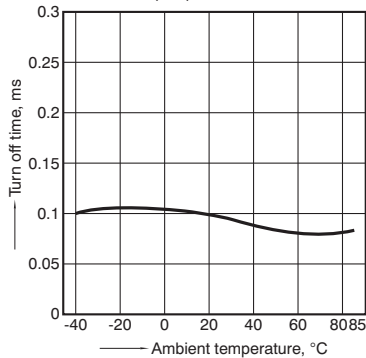

5. LED operate current vs. ambient temperature characteristics

Measured portion: between terminals 4 and 6;
 Load current: 100 mA

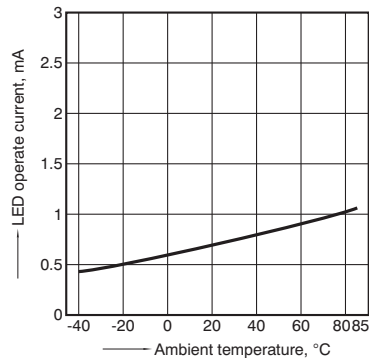

6. LED turn off current vs. ambient temperature characteristics

Measured portion: between terminals 4 and 6;
 Load current: 100 mA

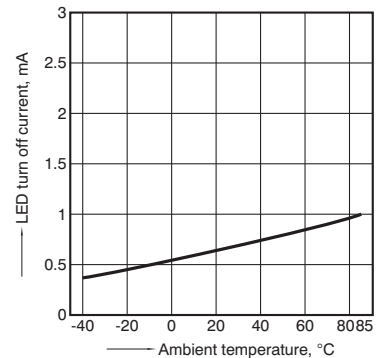

7. Off state leakage current vs. load voltage characteristics

Measured portion: between terminals 4 and 6;
 Ambient temperature: 25°C 77°F

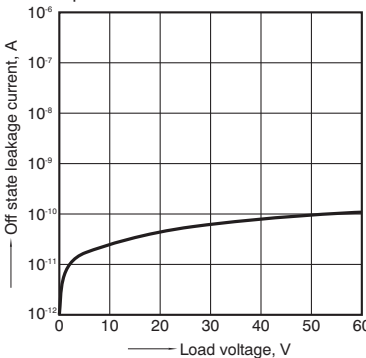

8. Current vs. voltage characteristics of output at MOS portion

Measured portion: between terminals 4 and 6;
 Ambient temperature: 25°C 77°F

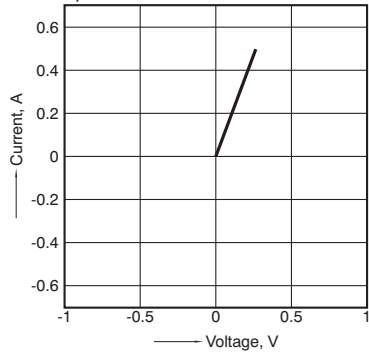

9. LED dropout voltage vs. ambient temperature characteristics

Measured portion: between terminals 1 and 2;
 LED current: 10 to 50 mA

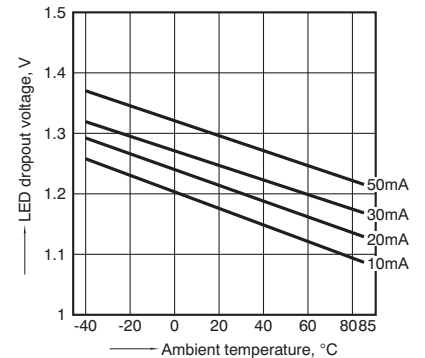

GU 1 Form A Short Circuit Protection (AQV112KL)

10. Turn on time vs. LED forward current characteristics

Measured portion: between terminals 4 and 6;
Load voltage: 10 V (DC); Load current: 100 mA (DC);
Ambient temperature: 25°C 77°F

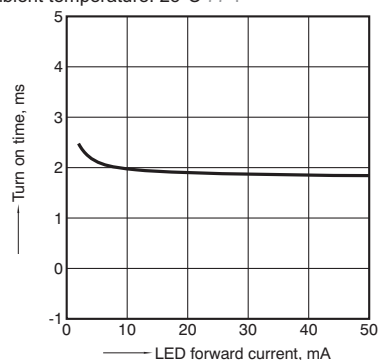

11. Turn off time vs. LED forward current characteristics

Measured portion: between terminals 4 and 6;
Load voltage: 10 V (DC); Load current: 100 mA (DC);
Ambient temperature: 25°C 77°F

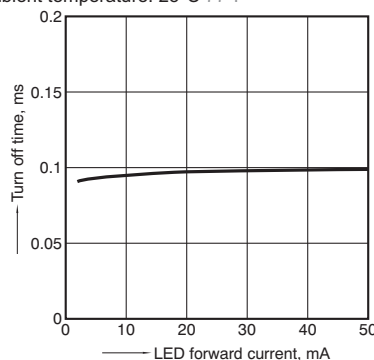

12. Output capacitance vs. applied voltage characteristics

Measured portion: between terminals 4 and 6;
Frequency: 1 MHz; Ambient temperature: 25°C 77°F

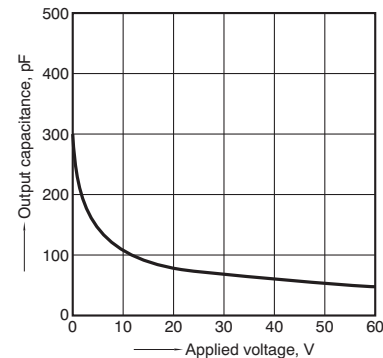

13. Short circuit peak current vs. time characteristics

Measured portion: between terminals 4 and 6;
LED current: 10 mA; Load resistance: 0;
Ambient temperature: 25°C 77°F

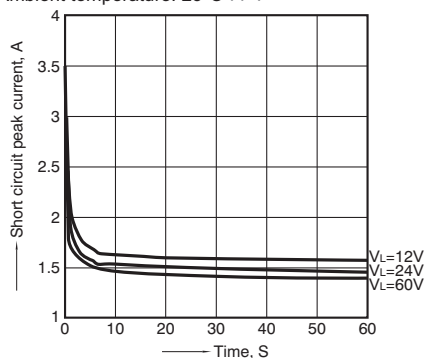

14. Short current monitoring interval vs. time characteristics

Measured portion: between terminals 4 and 6;
LED current: 10 mA; Load resistance: 0;
Ambient temperature: 25°C 77°F

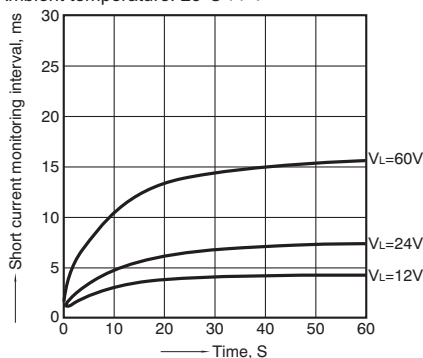

What is short circuit protection Non-latch type?

If the load current reaches a predetermined overcurrent level, the output-side short circuit protection function cuts off the load current. It then monitors the load current, and if it returns to normal, automatically recovers to normal relay operation.

In order to operate the short circuit protection function, ensure that the input current is at least $I_F = 10$ mA.

Operation chart (Non-latch type)

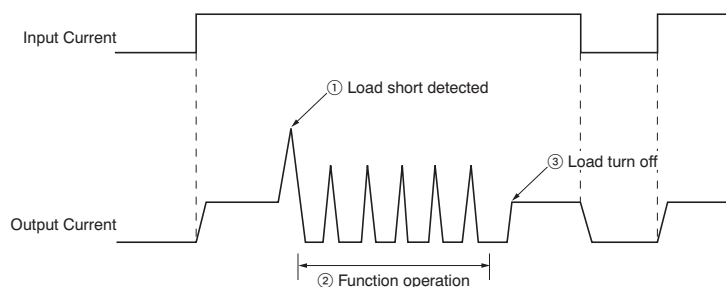

Panasonic

ideas for life



Miniature SOP4-pin type
with current limiting

PhotoMOS®
GU SOP 1 Form A
Current Limiting (AQY210LS)

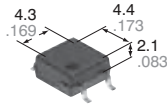

CAD Data

mm inch

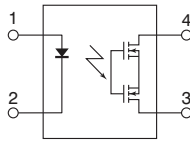

FEATURES

1. Current limiting function

To control an over current from flowing, the current limit function has been realized. It keeps an output current at a constant value when the current reaches a specified current limit value.

2. Enhances the capability of surge resistance between output terminals

The current limit function controls the ON time surge current to enhance the capability of surge resistance between output terminals.

3. Small SOP4-Pin package

The device comes in a super-miniature SO package 4-Pin type measuring (W) 4.3×(L) 4.4×(H) 2.1 mm (W) .169×(L) .173×(H) .083 inch

4. Controls low-level analog signals

5. Low-level off state leakage current

TYPICAL APPLICATIONS

- Telephone equipment
- Modem
- Measuring equipment

PhotoMOS

TYPES

	Output rating*		Package	Part No.			Packing quantity	
	Load voltage	Load current		Tube packing style	Tape and reel packing style		Tube	Tape and reel
					Picked from the 1/2-pin side	Picked from the 3/4-pin side		
AC/DC dual use	350V	120mA	SOP4-pin	AQY210LS	AQY210LSX	AQY210LSZ	1 tube contains: 100 pcs. 1 batch contains: 2,000 pcs.	1,000 pcs.

* Indicate the peak AC and DC values.

Note: For space reasons, only "210L" is marked on the product. The three initial letters of the part number "AQY", the surface mount terminal shape indicator "S" and the packing style indicator "X" or "Z" are not marked on the relay.

RATING

1. Absolute maximum ratings (Ambient temperature: 25°C 77°F)

Item		Symbol	AQY210LS	Remarks
Input	LED forward current	I_F	50 mA	
	LED reverse voltage	V_R	5 V	
	Peak forward current	I_{FP}	1 A	$f = 100 \text{ Hz}$, Duty factor = 0.1%
	Power dissipation	P_{in}	75 mW	
Output	Load voltage (peak AC)	V_L	350 V	
	Continuous load current	I_L	0.12 A	Peak AC, DC
	Power dissipation	P_{out}	300 mW	
Total power dissipation		P_T	350 mW	
I/O isolation voltage		V_{iso}	1,500 V AC	
Temperature limits	Operating	T_{opr}	-40°C to +85°C -40°F to +185°F	Non-condensing at low temperatures
	Storage	T_{stg}	-40°C to +100°C -40°F to +212°F	

GU SOP 1 Form A Current Limiting (AQY210LS)

2. Electrical characteristics (Ambient temperature: 25°C 77°F)

Item		Symbol	AQY210LS	Condition
Input	LED operate current	Typical	1.2 mA	$I_L = \text{Max.}$
		Maximum	3 mA	
	LED turn off current	Minimum	0.4 mA	$I_L = \text{Max.}$
		Typical	1.1 mA	
LED dropout voltage	Minimum	V_F	1.25 (1.14 V at $I_F = 5 \text{ mA}$)	$I_F = 50 \text{ mA}$
	Typical		1.5 V	
Output	On resistance	Typical	R_{on}	$I_F = 5 \text{ mA}$
		Maximum		$I_L = \text{Max.}$ Within 1 s on time
	Off state leakage current	Maximum	I_{Leak}	1 μA
Current limit		Typical	—	0.18 A $I_F = 5 \text{ mA}$
Transfer characteristics	Turn on time*	Typical	T_{on}	0.5 ms $I_F = 5 \text{ mA}$
		Maximum		2.0 ms $I_L = \text{Max.}$
	Turn off time*	Typical	T_{off}	0.08 ms $I_F = 5 \text{ mA}$
		Maximum		1.0 ms $I_L = \text{Max.}$
	I/O capacitance	Typical	C_{iso}	0.8 pF $f = 1 \text{ MHz}$
		Maximum		1.5 pF $V_B = 0 \text{ V}$
Initial I/O isolation resistance	Minimum	R_{iso}	1,000 M Ω 500 V DC	

*Turn on/Turn off time

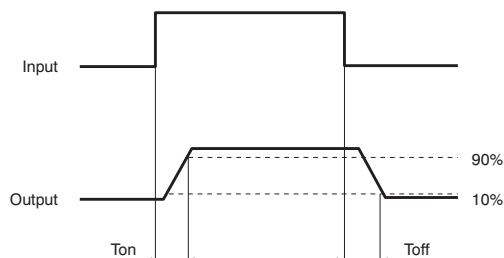

RECOMMENDED OPERATING CONDITIONS

Please obey the following conditions to ensure proper relay operation and resetting.

Item	Symbol	Recommended value	Unit
Input LED current	I_F	5	mA

■ For Dimensions, see page 62.

■ For Schematic and Wiring Diagrams, see page 64.

■ For Cautions for Use, see page 71.

■ These products are not designed for automotive use.

If you are considering to use these products for automotive applications, please contact your local Panasonic technical representative.

For more information, see page 80.

REFERENCE DATA

1. Load current vs. ambient temperature characteristics

Allowable ambient temperature:

-40°C to +85°C

-40°F to +185°F

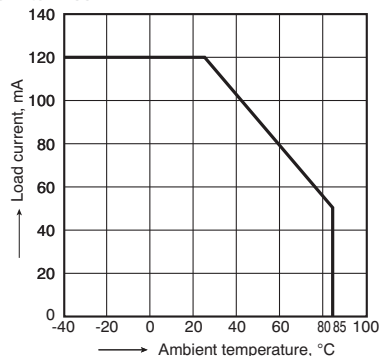

2. On resistance vs. ambient temperature characteristics

Measured portion: between terminals 3 and 4;

LED current: 5 mA; Load voltage: Max. (DC)

Continuous load current: Max. (DC)

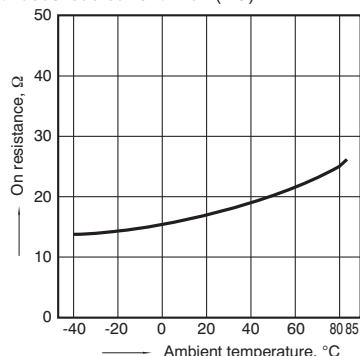

3. Turn on time vs. ambient temperature characteristics

LED current: 5 mA; Load voltage: Max. (DC);

Continuous load current: Max. (DC)

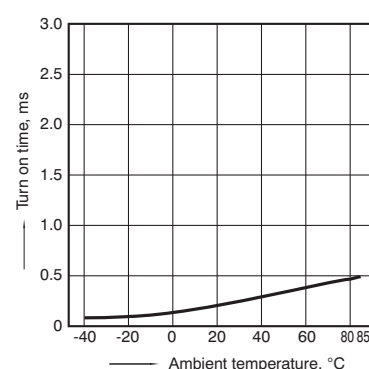

GU SOP 1 Form A Current Limiting (AQY210LS)

4. Turn off time vs. ambient temperature characteristics

LED current: 5 mA; Load voltage: Max.(DC);
Continuous load current: Max.(DC)

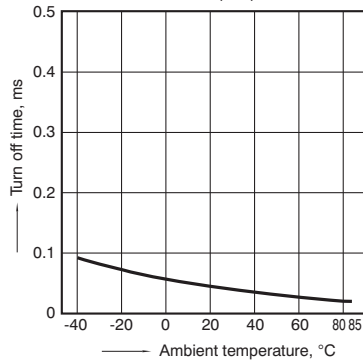

5. LED operate current vs. ambient temperature characteristics

Load voltage: Max.(DC);
Continuous load current: Max.(DC)

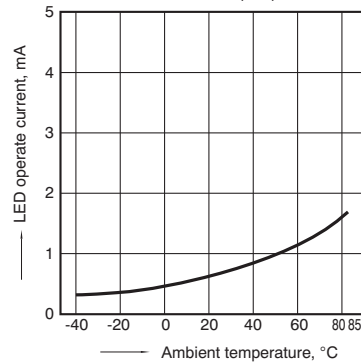

6. LED turn off current vs. ambient temperature characteristics

Load voltage: Max.(DC);
Continuous load current: Max.(DC)

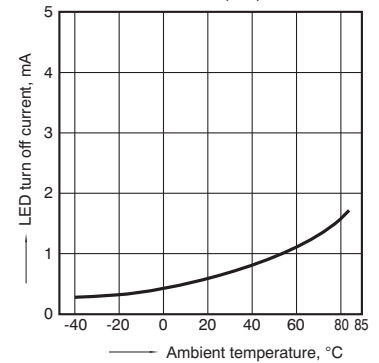

7. LED dropout voltage vs. ambient temperature characteristics

LED current: 5 to 50 mA

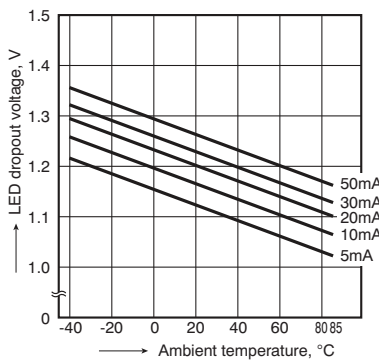

8. Current vs. voltage characteristics of output at MOS portion

Measured portion: between terminals 3 and 4;
Ambient temperature: 25°C 77°F

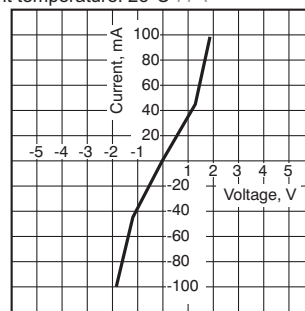

9. Off state leakage current vs. load voltage characteristics

Measured portion: between terminals 3 and 4;
Ambient temperature: 25°C 77°F

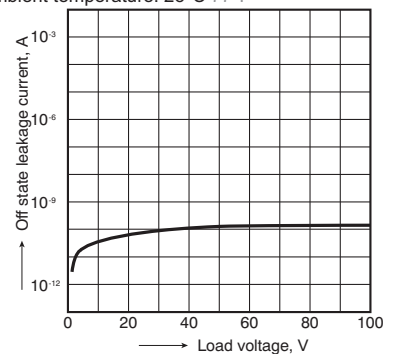

10. Turn on time vs. LED forward current characteristics

Measured portion: between terminals 3 and 4;
Load voltage: Max.(DC); Continuous load current: Max.(DC); Ambient temperature: 25°C 77°F

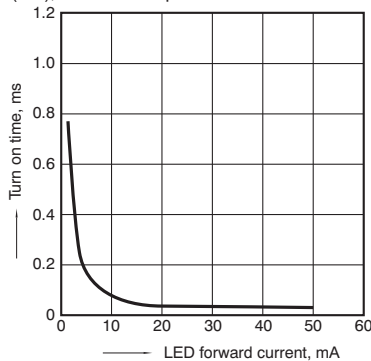

11. Turn off time vs. LED forward current characteristics

Measured portion: between terminals 3 and 4;
Load voltage: Max.(DC); Continuous load current: Max.(DC); Ambient temperature: 25°C 77°F

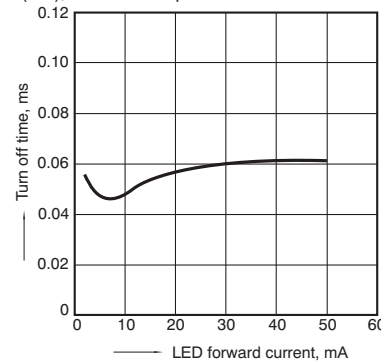

12. Output capacitance vs. applied voltage characteristics

Measured portion: between terminals 3 and 4;
Frequency: 1 MHz; Ambient temperature: 25°C 77°F

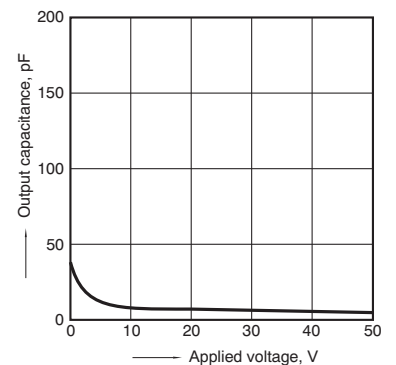

What is current limit?

When a load current reaches the specified output control current, a current limit function works against the load current to keep the current a constant value.

The current limit circuit built into the PhotoMOS relay thus controls the instantaneous load current to effectively ensure circuit safety.

This safety feature protects circuits downstream of the PhotoMOS relay against over-current.

But, if the current-limiting feature is used longer than the specified time, the PhotoMOS relay can be destroyed. Therefore, set the output loss to the max. rate or less.

- Comparison of output voltage and output current characteristics

V-I Characteristics

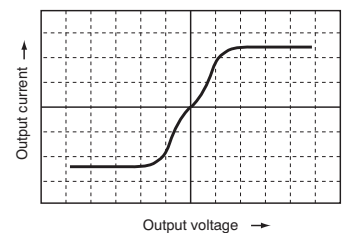

Panasonic

ideas for life



**DIP4-pin type with
current limiting and
reinforced insulation**

**PhotoMOS[®]
GU 1 Form A**
Current Limiting (AQY210HL)

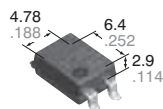
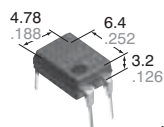

CAD Data

mm inch

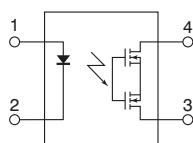

FEATURES

1. Current Limiting Function

To control an over current from flowing, the current limit function has been realized. It keeps an output current at a constant value when the current reaches a specified current limit value.

2. Enhances the capability of surge resistance between output terminals

The current limit function controls the ON time surge current to enhance the capability of surge resistance between output terminals.

3. Reinforced insulation of 5,000 V

More than 0.4 mm internal insulation distance between inputs and outputs. Con-forms to EN41003, EN60950 (reinforced insulation).

4. Controls low-level analog signals

PhotoMOS relays feature extremely low closed-circuit offset voltage to enable control of low-level analog signals without distortion.

5. High sensitivity and low on-resistance

6. Low-level off state leakage current

TYPICAL APPLICATIONS

- Telephone equipment
- Modem

TYPES

	I/O isolation voltage	Output rating*		Package	Part No.				Packing quantity	
					Through hole terminal	Surface-mount terminal				
						Tube packing style	Tape and reel packing style		Tube	Tape and reel
							Picked from the 1/2-pin side	Picked from the 3/4-pin side		
AC/DC dual use	Reinforced 5,000 V	350 V	120 mA	DIP4-pin	AQY210HL	AQY210HLA	AQY210HLAX	AQY210HLAZ	1 tube contains: 100 pcs. 1 batch contains: 1,000 pcs.	1,000 pcs.

*Indicate the peak AC and DC values.

Note: For space reasons, only "210HL" is marked on the product. The three initial letters of the part number "AQY", the surface mount terminal shape indicator "A" and the packing style indicator "X" or "Z" are not marked on the relay.

RATING

1. Absolute maximum ratings (Ambient temperature: 25°C 77°F)

Item		Symbol	AQY210HL(A)	Remarks
Input	LED forward current	I _F	50 mA	
	LED reverse voltage	V _R	5 V	
	Peak forward current	I _{FP}	1 A	f = 100 Hz, Duty factor = 0.1%
	Power dissipation	P _{in}	75 mW	
Output	Load voltage (peak AC)	V _L	350 V	
	Continuous load current	I _L	0.12 A	Peak AC, DC
	Power dissipation	P _{out}	500 mW	
Total power dissipation		P _T	550 mW	
I/O isolation voltage		V _{iso}	5,000 V AC	
Temperature limits	Operating	T _{opr}	-40°C to +85°C -40°F to +185°F	Non-condensing at low temperatures
	Storage	T _{stg}	-40°C to +100°C -40°F to +212°F	

GU 1 Form A Current Limiting (AQY210HL)

2. Electrical characteristics (Ambient temperature: 25°C 77°F)

Item			Symbol	AQY210HL(A)	Condition
Input	LED operate current	Typical	I_{Fon}	1.2 mA	$I_L = \text{Max.}$
		Maximum		3.0 mA	
	LED turn off current	Minimum	I_{Foff}	0.4 mA	$I_L = \text{Max.}$
		Typical		1.1 mA	
LED dropout voltage	Minimum	V_F	1.25 (1.14 V at $I_F = 5 \text{ mA}$)		$I_F = 50 \text{ mA}$
	Typical		1.5 V		
Output	On resistance	Typical	R_{on}	20Ω	$I_F = 5 \text{ mA}$ $I_L = \text{Max.}$ Within 1 s on time
		Maximum		25Ω	
	Off state leakage current	Maximum	I_{Leak}	1μA	$I_F = 0 \text{ mA}$ $V_L = \text{Max.}$
Transfer characteristics	Current limit	Typical	—	0.18 A	$I_F = 5 \text{ mA}$
	Turn on time*	Typical	T_{on}	0.5 ms	$I_F = 5 \text{ mA}$ $I_L = \text{Max.}$
		Maximum		2.0 ms	
	Turn off time*	Typical	T_{off}	0.08 ms	$I_F = 5 \text{ mA}$ $I_L = \text{Max.}$
		Maximum		1.0 ms	
	I/O capacitance	Typical	C_{iso}	0.8 pF	$f = 1 \text{ MHz}$ $V_B = 0 \text{ V}$
		Maximum		1.5 pF	
Initial I/O isolation resistance	Minimum	R_{iso}	1,000 MΩ	500 V DC	

*Turn on/Turn off time

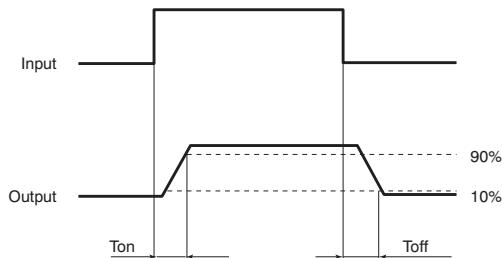

RECOMMENDED OPERATING CONDITIONS

Please obey the following conditions to ensure proper relay operation and resetting.

Item	Symbol	Recommended value	Unit
Input LED current	I_F	5 to 10	mA

■ For Dimensions, see page 60.

■ For Schematic and Wiring Diagrams, see page 64.

■ For Cautions for Use, see page 71.

■ These products are not designed for automotive use.

If you are considering to use these products for automotive applications, please contact your local Panasonic technical representative.

For more information, see page 80.

REFERENCE DATA

1. Load current vs. ambient temperature characteristics

Allowable ambient temperature: -40°C to +85°C
-40°F to +185°F

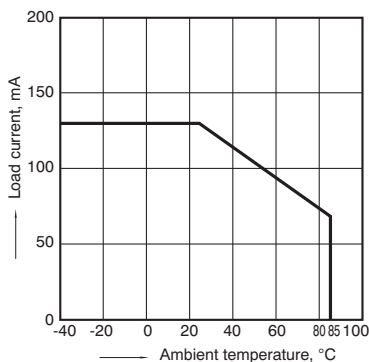

2. On resistance vs. ambient temperature characteristics

Measured portion: between terminals 3 and 4;
LED current: 5 mA; Load voltage: Max. (DC)
Continuous load current: Max. (DC)

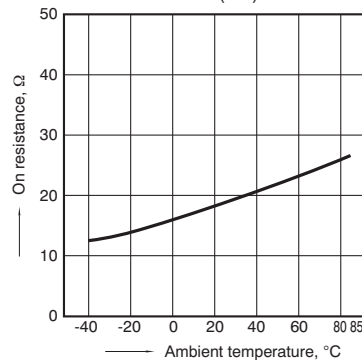

3. Turn on time vs. ambient temperature characteristics

LED current: 5 mA; Load voltage: Max. (DC);
Continuous load current: Max. (DC)

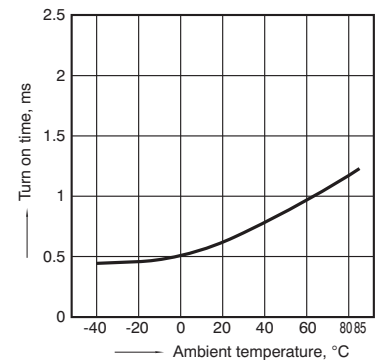

GU 1 Form A Current Limiting (AQY210HL)

4. Turn off time vs. ambient temperature characteristics

LED current: 5 mA; Load voltage: Max.(DC);
Continuous load current: Max.(DC)

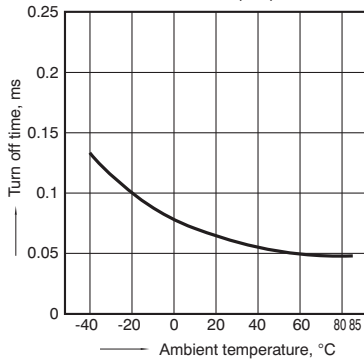

5. LED operate current vs. ambient temperature characteristics

Load voltage: Max.(DC);
Continuous load current: Max.(DC)

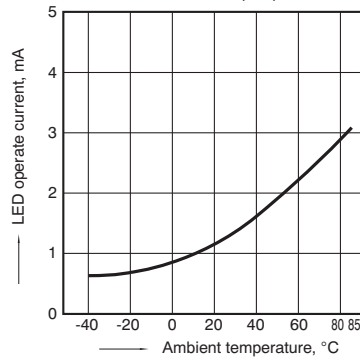

6. LED turn off current vs. ambient temperature characteristics

Load voltage: Max.(DC);
Continuous load current: Max.(DC)

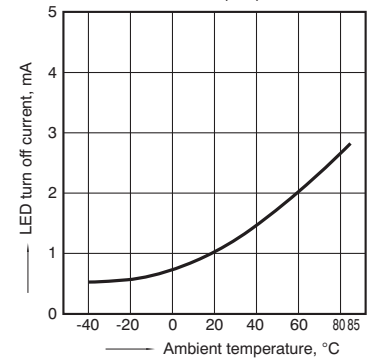

7. LED dropout voltage vs. ambient temperature characteristics

LED current: 5 to 50 mA

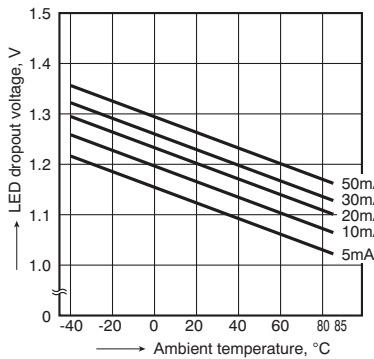

8. Current vs. voltage characteristics of output at MOS portion

Measured portion: between terminals 3 and 4;
Ambient temperature: 25°C 77°F

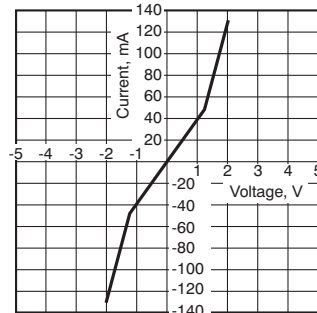

9. Off state leakage current vs. load voltage characteristics

Measured portion: between terminals 3 and 4;
Ambient temperature: 25°C 77°F

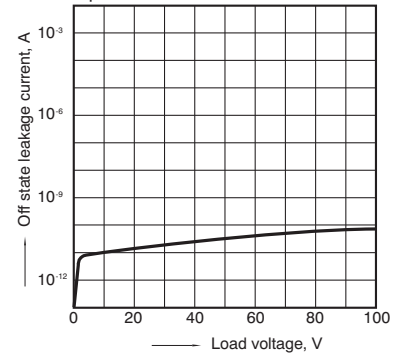

10. Turn on time vs. LED forward current characteristics

Measured portion: between terminals 3 and 4;
Load voltage: Max.(DC); Continuous load current:
Max.(DC); Ambient temperature: 25°C 77°F

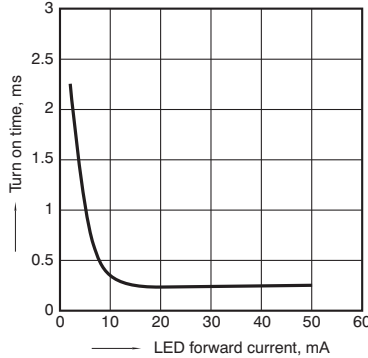

11. Turn off time vs. LED forward current characteristics

Measured portion: between terminals 3 and 4;
Load voltage: Max.(DC); Continuous load current:
Max.(DC); Ambient temperature: 25°C 77°F

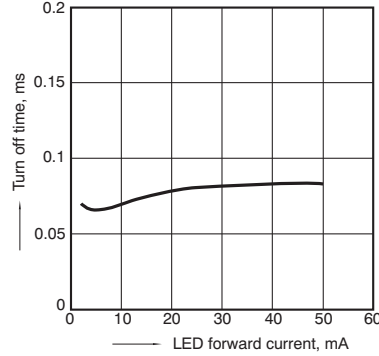

12. Output capacitance vs. applied voltage characteristics

Measured portion: between terminals 3 and 4;
Frequency: 1 MHz; Ambient temperature: 25°C 77°F

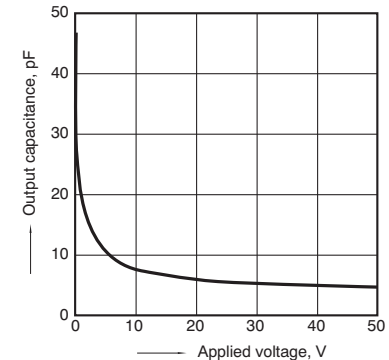

What is current limit?

When a load current reaches the specified output control current, a current limit function works against the load current to keep the current a constant value.

The current limit circuit built into the PhotoMOS relay thus controls the instantaneous load current to effectively ensure circuit safety.

This safety feature protects circuits downstream of the PhotoMOS relay against over-current.

But, if the current-limiting feature is used longer than the specified time, the PhotoMOS relay can be destroyed. Therefore, set the output loss to the max. rate or less.

- Comparison of output voltage and output current characteristics

V-I Characteristics

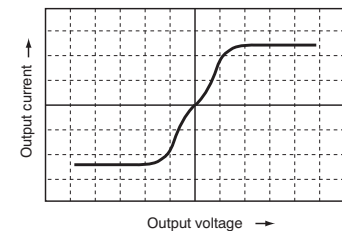

Panasonic

ideas for life



Two output type with
current limiting and
reinforced insulation

PhotoMOS[®]
GU 2 Form A
Current Limiting (AQW210HL)

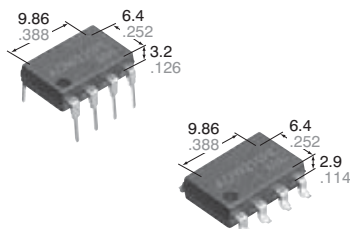

CAD Data

mm inch

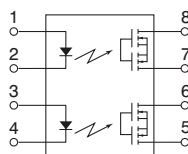

FEATURES

1. Current Limiting Function

To control an over current from flowing, the current limit function has been realized. It keeps an output current at a constant value when the current reaches a specified current limit value.

2. Enhances the capability of surge resistance between output terminals

The current limit function controls the ON time surge current to enhance the capability of surge resistance between output terminals.

3. Reinforced insulation of 5,000 V

More than 0.4 mm internal insulation distance between inputs and outputs. Con-forms to EN41003, EN60950 (reinforced insulation).

4. Applicable for 2 Form A use as well as two independent 1 Form A use.

5. Controls low-level analog signals

6. High sensitivity and high speed response.

Can control max. 0.12 A load current with 5 mA input current. This enables fast operation speed of typ. 0.5 ms

7. Low-level off state leakage current

TYPICAL APPLICATIONS

- Telephone equipment
- Modem

TYPES

	I/O isolation voltage	Output rating*		Package	Part No.				Packing quantity	
		Load voltage	Load current		Through hole terminal	Surface-mount terminal		Tube	Tape and reel	
						Tape and reel packing style				
					Tube packing style	Picked from the 1/2/3/4-pin side	Picked from the 5/6/7/8-pin side			
AC/DC dual use	Reinforced 5,000 V AC	350 V	100 mA	DIP8-pin	AQW210HL	AQW210HLA	AQW210HLAX	AQW210HLAZ	1 tube contains: 50 pcs. 1 batch contains: 500 pcs.	1,000 pcs.

*Indicate the peak AC and DC values.

Note: The surface mount terminal shape indicator "A" and the packing style indicator "X" or "Z" are not marked on the relay.

RATING

1. Absolute maximum ratings (Ambient temperature: 25°C 77°F)

Item		Symbol	AQW210HL(A)	Remarks
Input	LED forward current	I_F	50 mA	
	LED reverse voltage	V_R	5 V	
	Peak forward current	I_{FP}	1 A	$f = 100 \text{ Hz}$, Duty factor = 0.1%
	Power dissipation	P_{in}	75 mW	
Load voltage (peak AC)		V_L	350 V	
Output	Continuous load current	I_L	0.1 A (0.12 A)	Peak AC, DC (): in case of using only 1 channel
	Power dissipation	P_{out}	800 mW	
Total power dissipation		P_T	850 mW	
I/O isolation voltage		V_{iso}	5,000 V AC	
Temperature limits	Operating	T_{opr}	-40°C to +85°C -40°F to +185°F	Non-condensing at low temperatures
	Storage	T_{stg}	-40°C to +100°C -40°F to +212°F	

GU 2 Form A Current Limiting (AQW210HL)

2. Electrical characteristics (Ambient temperature: 25°C 77°F)

Item		Symbol	AQW210HL(A)	Condition	
Input	LED operate current	Typical	1.2 mA	$I_L = \text{Max.}$	
		Maximum	3.0 mA		
	LED turn off current	Minimum	0.4 mA	$I_L = \text{Max.}$	
		Typical	1.1 mA		
LED dropout voltage	Minimum	V_F	1.25 (1.14 V at $I_F = 5 \text{ mA}$)	$I_F = 50 \text{ mA}$	
	Typical		1.5 V		
Output	On resistance	Typical	20Ω	$I_F = 5 \text{ mA}$ $I_L = \text{Max.}$ Within 1 s on time	
		Maximum	25Ω		
	Off state leakage current	Maximum	I_{Leak}	1μA	$I_F = 0 \text{ mA}$ $V_L = \text{Max.}$
Current limit	Typical	—	0.18 A	$I_F = 5 \text{ mA}$	
Transfer characteristics	Turn on time*	Typical	0.5 ms	$I_F = 5 \text{ mA}$ $I_L = \text{Max.}$	
		Maximum	2.0 ms		
	Turn off time*	Typical	T_{off}	0.08 ms	$I_F = 5 \text{ mA}$ $I_L = \text{Max.}$
		Maximum		1.0 ms	
	I/O capacitance	Typical	C_{iso}	0.8 pF	$f = 1 \text{ MHz}$ $V_B = 0 \text{ V}$
		Maximum		1.5 pF	
Initial I/O isolation resistance	Minimum	R_{iso}	1,000 MΩ	500 V DC	

*Turn on/Turn off time

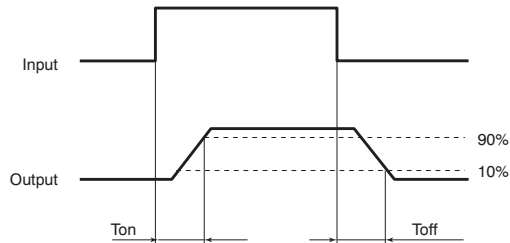

RECOMMENDED OPERATING CONDITIONS

Please obey the following conditions to ensure proper relay operation and resetting.

Item	Symbol	Recommended value	Unit
Input LED current	I_F	5 to 10	mA

■ For Dimensions, see page 61.

■ For Schematic and Wiring Diagrams, see page 65.

■ For Cautions for Use, see page 71.

■ These products are not designed for automotive use.

If you are considering to use these products for automotive applications, please contact your local Panasonic technical representative.

For more information, see page 80.

REFERENCE DATA

1. Load current vs. ambient temperature characteristics

Allowable ambient temperature: -40°C to +85°C
-40°F to +185°F

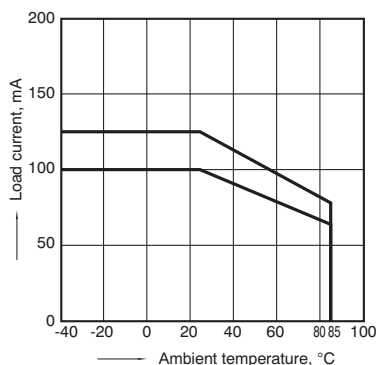

2. On resistance vs. ambient temperature characteristics

Measured portion: between terminals 5 and 6, 7 and 8;
LED current: 5 mA; Load voltage: Max. (DC)
Continuous load current: Max. (DC)

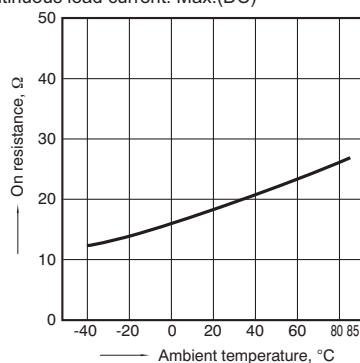

3. Turn on time vs. ambient temperature characteristics

LED current: 5 mA; Load voltage: Max. (DC);
Continuous load current: Max. (DC)

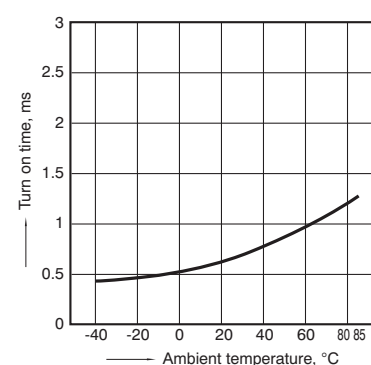

GU 2 Form A Current Limiting (AQW210HL)

4. Turn off time vs. ambient temperature characteristics

LED current: 5 mA; Load voltage: Max.(DC);
Continuous load current: Max.(DC)

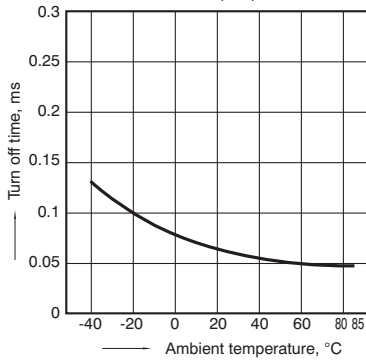

5. LED operate current vs. ambient temperature characteristics

Load voltage: Max.(DC);
Continuous load current: Max.(DC)

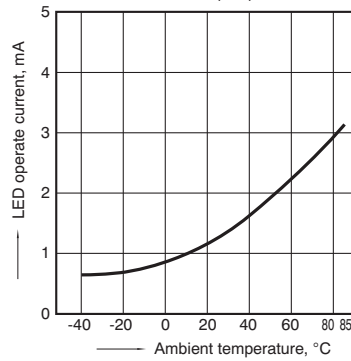

6. LED turn off current vs. ambient temperature characteristics

Load voltage: Max.(DC);
Continuous load current: Max.(DC)

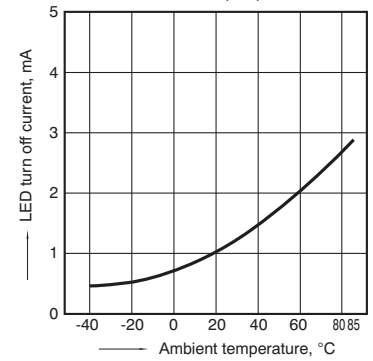

7. LED dropout voltage vs. ambient temperature characteristics

LED current: 5 to 50 mA

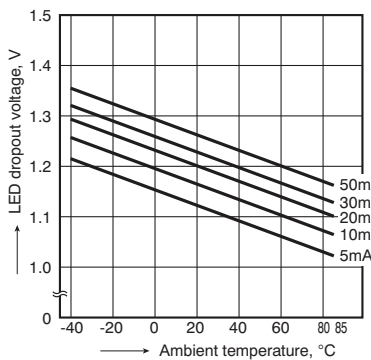

8. Current vs. voltage characteristics of output at MOS portion

Measured portion: between terminals 5 and 6, 7 and 8;
Ambient temperature: 25°C 77°F

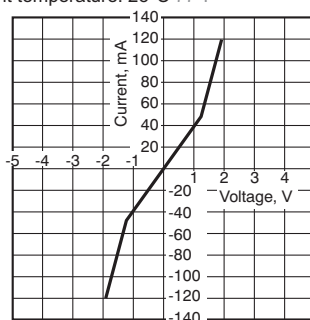

9. Off state leakage current vs. load voltage characteristics

Measured portion: between terminals 5 and 6, 7 and 8;
Ambient temperature: 25°C 77°F

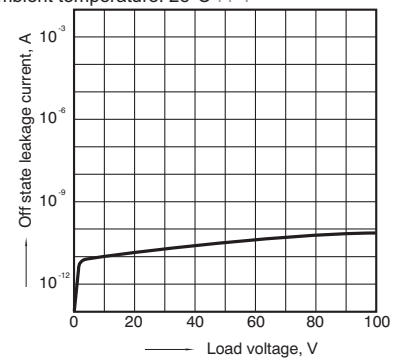

10. Turn on time vs. LED forward current characteristics

Measured portion: between terminals 5 and 6, 7 and 8;
Load voltage: Max.(DC); Continuous load current: Max.(DC); Ambient temperature: 25°C 77°F

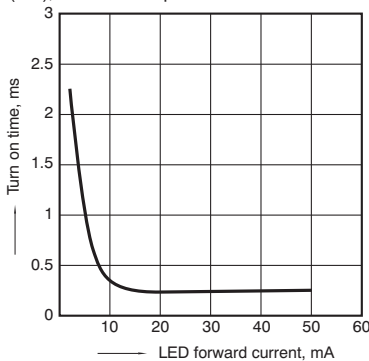

11. Turn off time vs. LED forward current characteristics

Measured portion: between terminals 5 and 6, 7 and 8;
Load voltage: Max.(DC); Continuous load current: Max.(DC); Ambient temperature: 25°C 77°F

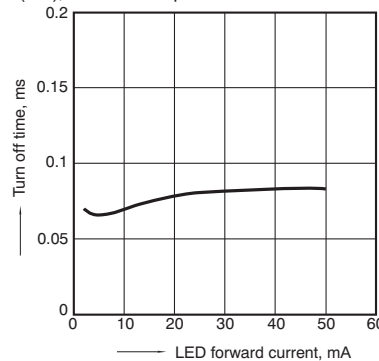

12. Output capacitance vs. applied voltage characteristics

Measured portion: between terminals 5 and 6, 7 and 8;
Frequency: 1 MHz; Ambient temperature: 25°C 77°F

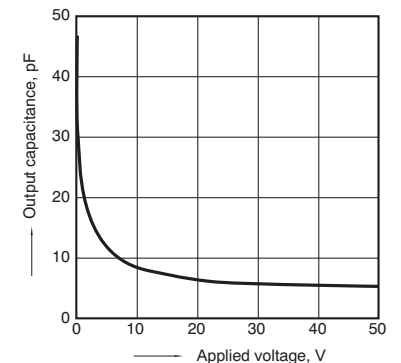

What is current limit?

When a load current reaches the specified output control current, a current limit function works against the load current to keep the current a constant value.

The current limit circuit built into the PhotoMOS relay thus controls the instantaneous load current to effectively ensure circuit safety.

This safety feature protects circuits downstream of the PhotoMOS relay against over-current.

But, if the current-limiting feature is used longer than the specified time, the PhotoMOS relay can be destroyed. Therefore, set the output loss to the max. rate or less.

- Comparison of output voltage and output current characteristics

V-I Characteristics

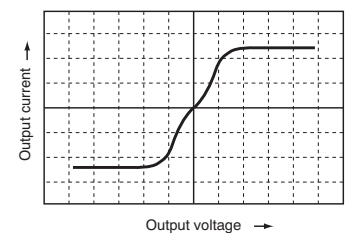

Panasonic

ideas for life



High cost-performance
DIP4-pin type with
reinforced insulation

PhotoMOS[®]
GU-E 1 Form A
(AQY210EH)

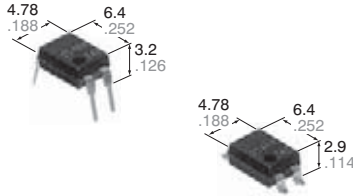

CAD Data

mm inch

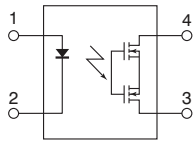

FEATURES

1. Reinforced insulation of 5,000 V

More than 0.4 mm internal insulation distance between inputs and outputs. Con-forms to EN41003, EN60950 (reinforced insulation).

2. Controls low-level analog signals

PhotoMOS relays feature extremely low closed-circuit offset voltage to enable control of low-level analog signals without distortion.

3. High sensitivity and low on-resistance

Can control max. 0.13 A load current with 5 mA input current.

Low on-resistance of typ. 25Ω (AQY211EH).

4. Low-level off state leakage current of max. 1 μA

TYPICAL APPLICATIONS

- Modem
- Telephone equipment
- Security equipment
- Sensing equipment

TYPES

	I/O isolation voltage	Output rating*		Package	Part No.				Packing quantity	
					Through hole terminal	Surface-mount terminal			Tube	Tape and reel
						Tube packing style	Tape and reel packing style			
							Picked from the 1/2-pin side	Picked from the 3/4-pin side		
AC/DC dual use	Reinforced 5,000 V	30 V	1,000 mA	DIP4-pin	AQY211EH	AQY211EHA	AQY211EHAX	AQY211EHAZ	1 tube contains: 100 pcs. 1 batch contains: 1,000 pcs.	1,000 pcs.
		60 V	550 mA		AQY212EH	AQY212EHA	AQY212EHAX	AQY212EHAZ		
		350 V	130 mA		AQY210EH	AQY210EHA	AQY210EHAX	AQY210EHAZ		
		400 V	120 mA		AQY214EH	AQY214EHA	AQY214EHAX	AQY214EHAZ		
		600 V	50 mA		AQY216EH	AQY216EHA	AQY216EHAX	AQY216EHAZ		

*Indicate the peak AC and DC values.

Note: For space reasons, the initial letters of the part number "AQY", the surface mount terminal shape indicator "A" and the packing style indicator "X" or "Z" are not marked on the relay. (Ex. the label for product number AQY211EHAX is 211EH)

RATING

1. Absolute maximum ratings (Ambient temperature: 25°C 77°F)

Item		Symbol	AQY211EH(A)	AQY212EH(A)	AQY210EH(A)	AQY214EH(A)	AQY216EH(A)	Remarks
Input	LED forward current	I _F	50mA					
	LED reverse voltage	V _R	5 V					
	Peak forward current	I _{FP}	1 A					f = 100 Hz, Duty factor = 0.1%
	Power dissipation	P _{in}	75mW					
Output	Load voltage (peak AC)	V _L	30 V	60 V	350 V	400 V	600 V	
	Continuous load current	I _L	1 A	0.55 A	0.13 A	0.12 A	0.05 A	Peak AC, DC
	Peak load current	I _{peak}	3 A	1.5 A	0.4 A	0.3 A	0.15 A	100 ms (1 shot), V _L = DC
	Power dissipation	P _{out}	500mW					
Total power dissipation		P _T	550mW					
I/O isolation voltage		V _{iso}	5,000 V AC					
Temperature limits	Operating	T _{opr}	-40°C to +85°C -40°F to +185°F					Non-condensing at low temperatures
	Storage	T _{stg}	-40°C to +100°C -40°F to +212°F					

GU-E 1 Form A (AQY21○EH)

2. Electrical characteristics (Ambient temperature: 25°C 77°F)

Item		Symbol	AQY211EH(A)	AQY212EH(A)	AQY210EH(A)	AQY214EH(A)	AQY216EH(A)	Condition
Input	LED operate current	Typical	1.2mA					I _L =Max.
		Maximum	3.0mA					
	LED turn off current	Minimum	0.4mA					I _L =Max.
		Typical	1.1mA					
LED dropout voltage	Typical	V _F	1.25 (1.14 V at I _F =5mA)					I _F =50mA
	Maximum		1.5V					
Output	On resistance	Typical	0.25Ω	0.85Ω	18Ω	26Ω	52Ω	I _F =5mA I _L =Max. Within 1 s on time
		Maximum	0.5Ω	2.5Ω	25Ω	35Ω	120Ω	
	Off state leakage current	Maximum	1μA					I _F =0mA V _I =Max.
Transfer characteristics	Turn on time*	Typical	1.5ms	1ms	0.5ms		I _F =5mA I _L =Max.	
		Maximum	5ms	4ms	2.0ms			
	Turn off time*	Typical	0.1ms	0.05ms	0.08ms	0.04ms	I _F =5mA I _L =Max.	
		Maximum	1.0ms					
	I/O capacitance	Typical	0.8pF					f=1MHz V _B =0V
		Maximum	1.5pF					
Initial I/O isolation resistance	Minimum	R _{iso}	1,000MΩ					500V DC

*Turn on/Turn off time

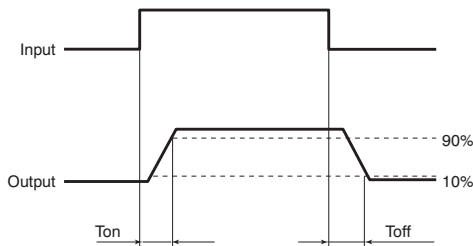

RECOMMENDED OPERATING CONDITIONS

Please obey the following conditions to ensure proper relay operation and resetting.

Item	Symbol	Recommended value	Unit
Input LED current	I _F	5 to 10	mA

■ For Dimensions, see page 60.

■ For Schematic and Wiring Diagrams, see page 64.

■ For Cautions for Use, see page 71.

■ These products are not designed for automotive use.

If you are considering to use these products for automotive applications, please contact your local Panasonic technical representative.

For more information, see page 80.

REFERENCE DATA

1-(1). Load current vs. ambient temperature characteristics

Allowable ambient temperature: -40°C to +85°C
-40°F to +185°F

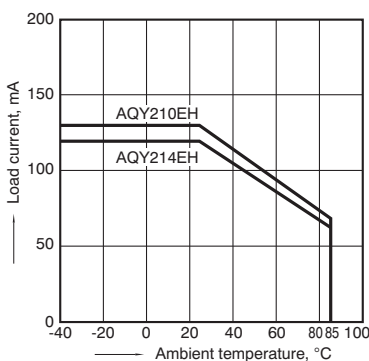

1-(2). Load current vs. ambient temperature characteristics

Allowable ambient temperature: -40°C to +85°C
-40°F to +185°F

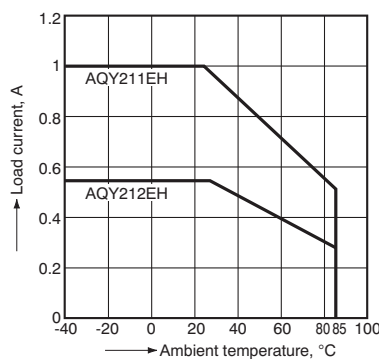

1-(3). Load current vs. ambient temperature characteristics

Allowable ambient temperature: -40°C to +85°C
-40°F to +185°F

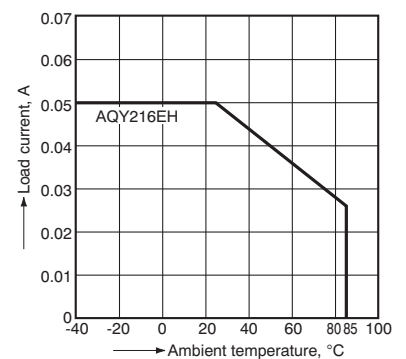

GU-E 1 Form A (AQY210EH)

2-(1). On resistance vs. ambient temperature characteristics

Measured portion: between terminals 3 and 4;
LED current: 5 mA; Load voltage: Max. (DC);
Continuous load current: Max. (DC)

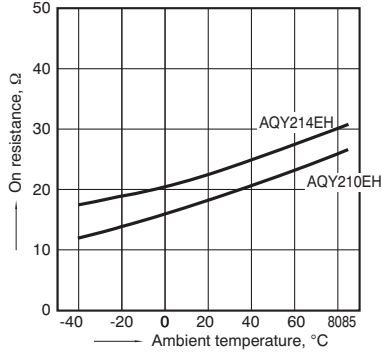

2-(2). On resistance vs. ambient temperature characteristics

Measured portion: between terminals 3 and 4;
LED current: 5 mA; Load voltage: Max. (DC);
Continuous load current: Max. (DC)

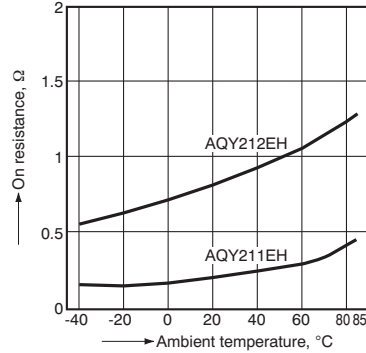

2-(3). On resistance vs. ambient temperature characteristics

Measured portion: between terminals 3 and 4;
LED current: 5 mA; Load voltage: Max. (DC);
Continuous load current: Max. (DC)

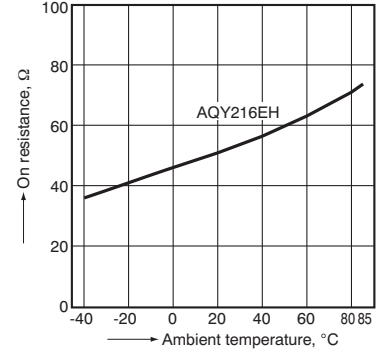

3-(1). Turn on time vs. ambient temperature characteristics

LED current: 5 mA; Load voltage: Max. (DC);
Continuous load current: Max. (DC)

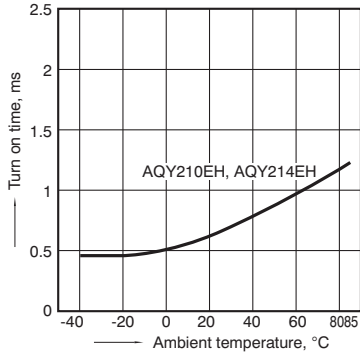

3-(2). Turn on time vs. ambient temperature characteristics

LED current: 5 mA; Load voltage: Max. (DC);
Continuous load current: Max. (DC)

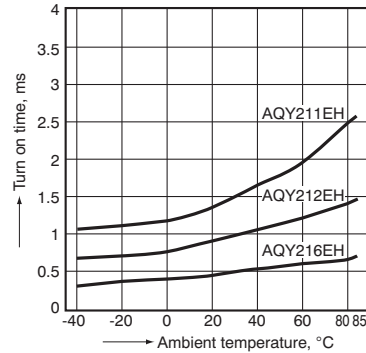

4-(1). Turn off time vs. ambient temperature characteristics

LED current: 5 mA; Load voltage: Max. (DC);
Continuous load current: Max. (DC)

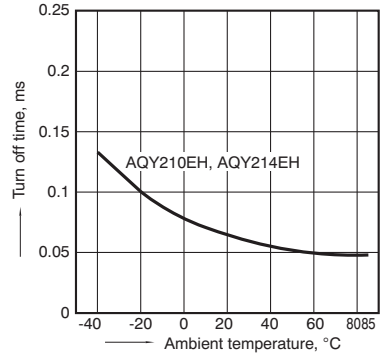

4-(2). Turn off time vs. ambient temperature characteristics

LED current: 5 mA; Load voltage: Max. (DC);
Continuous load current: Max. (DC)

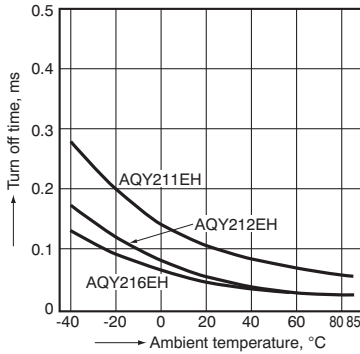

5. LED operate current vs. ambient temperature characteristics

Sample: All types; Load voltage: Max. (DC);
Continuous load current: Max. (DC)

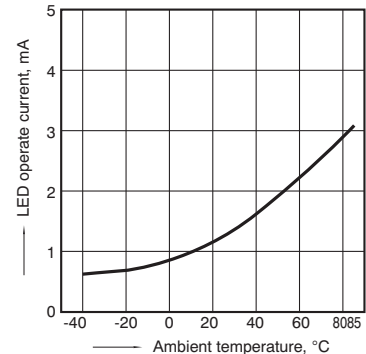

6. LED turn off current vs. ambient temperature characteristics

Sample: All types; Load voltage: Max. (DC);
Continuous load current: Max. (DC)

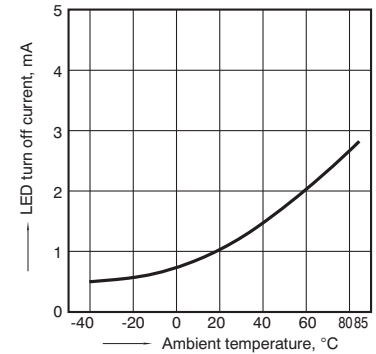

7. LED dropout voltage vs. ambient temperature characteristics

Sample: All types; LED current: 5 to 50 mA

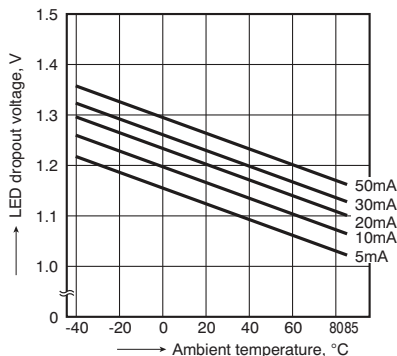

8-(1). Current vs. voltage characteristics of output at MOS portion

Measured portion: between terminals 3 and 4;
Ambient temperature: 25°C 77°F

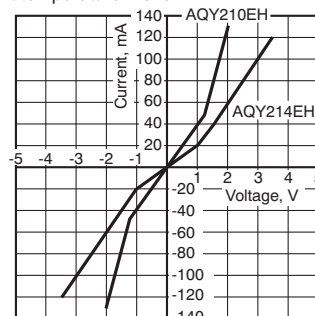

8-(2). Current vs. voltage characteristics of output at MOS portion

Measured portion: between terminals 3 and 4;
Ambient temperature: 25°C 77°F

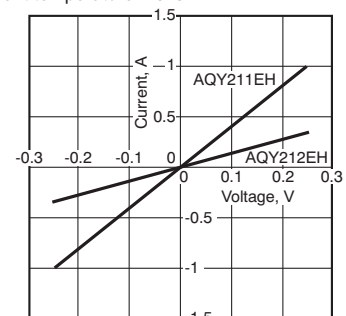

GU-E 1 Form A (AQY21○EH)

8-(3). Current vs. voltage characteristics of output at MOS portion

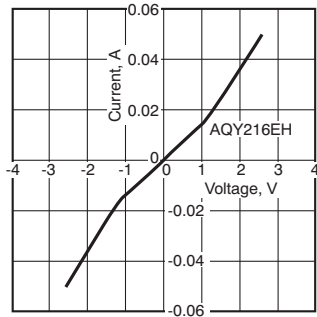
Measured portion: between terminals 3 and 4;
Ambient temperature: 25°C 77°F

9-(1). Off state leakage current vs. load voltage characteristics

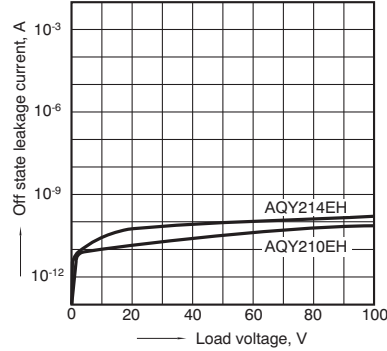
Measured portion: between terminals 3 and 4;
Ambient temperature: 25°C 77°F

9-(2). Off state leakage current vs. load voltage characteristics

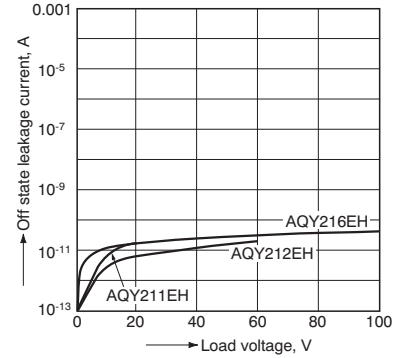
Measured portion: between terminals 3 and 4;
Ambient temperature: 25°C 77°F

10-(1). Turn on time vs. LED forward current characteristics

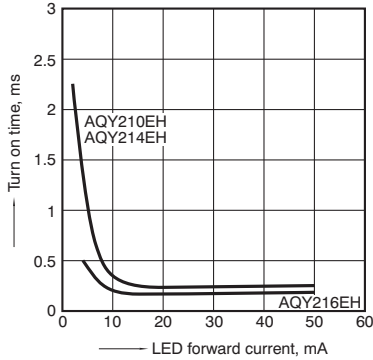
Measured portion: between terminals 3 and 4;
Load voltage: Max. (DC); Continuous load current: Max. (DC); Ambient temperature: 25°C 77°F

10-(2). Turn on time vs. LED forward current characteristics

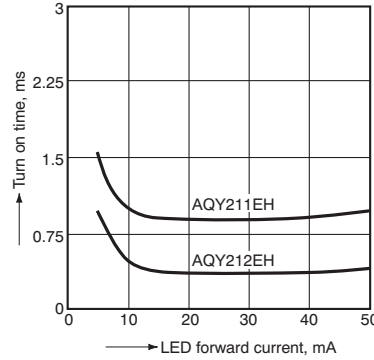
Measured portion: between terminals 3 and 4;
Load voltage: Max. (DC); Continuous load current: Max. (DC); Ambient temperature: 25°C 77°F

11-(1). Turn off time vs. LED forward current characteristics

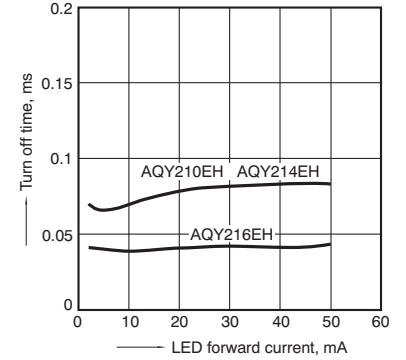
Measured portion: between terminals 3 and 4;
Load voltage: Max. (DC); Continuous load current: Max. (DC); Ambient temperature: 25°C 77°F

11-(2). Turn off time vs. LED forward current characteristics

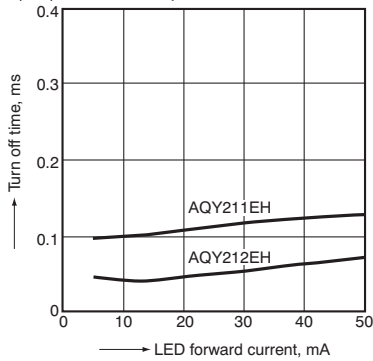
Measured portion: between terminals 3 and 4;
Load voltage: Max. (DC); Continuous load current: Max. (DC); Ambient temperature: 25°C 77°F

12-(1). Output capacitance vs. applied voltage characteristics

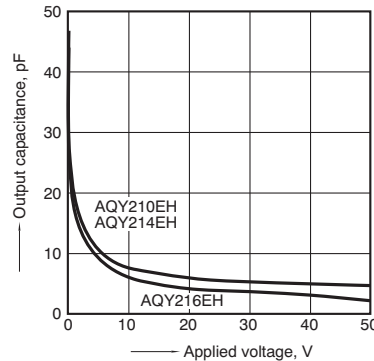
Measured portion: between terminals 3 and 4;
Frequency: 1 MHz; Ambient temperature: 25°C 77°F

12-(2). Output capacitance vs. applied voltage characteristics

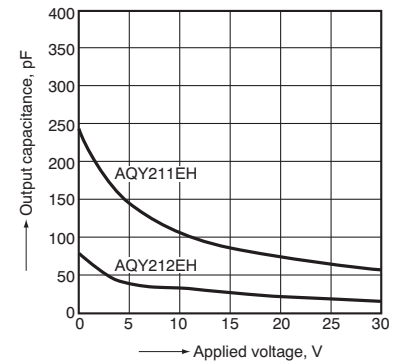
Measured portion: between terminals 3 and 4;
Frequency: 1 MHz; Ambient temperature: 25°C 77°F

Panasonic

ideas for life

RU US (Standard type) RU US BSI (Reinforced type)

High cost-performance
DIP6-pin type, reinforced
insulation available

PhotoMOS[®]
GU-E 1 Form A
(AQV210E, AQV210EH)

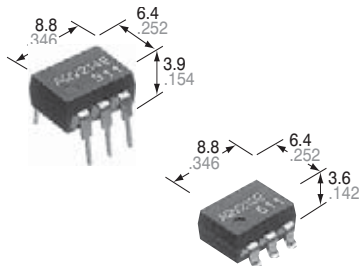

CAD Data

mm inch

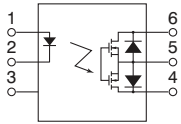

FEATURES

- Reinforced insulation of I/O isolation voltage 5,000V (Reinforced insulation type)**
- Controls low-level analog signals**
PhotoMOS relays feature extremely low closed-circuit offset voltage to enable control of low-level analog signals without distortion.
- Stable on-resistance**
- Low-level off state leakage current of max. 1 μ A**

TYPICAL APPLICATIONS

- High-speed inspection machines
- Telephone equipment
- Data communication equipment
- Computers

TYPES

	I/O isolation	Output rating*		Package	Part No.				Packing quantity	
		Load voltage	Load current		Through hole terminal	Surface-mount terminal		Tube	Tape and reel	
						Tape and reel packing style				
		Tube packing style			Picked from the 1/2/3-pin side	Picked from the 4/5/6-pin side				
AC/DC dual use	Standard 1,500 V AC	350 V	130 mA	DIP6-pin	AQV210E	AQV210EA	AQV210EAX	AQV210EAZ	1 tube contains: 50 pcs. 1 batch contains: 500 pcs.	1,000 pcs.
		400 V	120 mA		AQV214E	AQV214EA	AQV214EAX	AQV214EAZ		
	Reinforced 5,000 V	350 V	130 mA		AQV210EH	AQV210EHA	AQV210EHAX	AQV210EHAZ		
		400 V	120 mA		AQV214EH	AQV214EHA	AQV214EHAX	AQV214EHAZ		

*Indicate the peak AC and DC values.

Note: The surface mount terminal shape indicator "A" and the packing style indicator "X" or "Z" are not marked on the relay.

RATING

1. Absolute maximum ratings (Ambient temperature: 25°C 77°F)

Item		Sym- bol	Type of connec- tion	AQV210E(A)	AQV214E(A)	AQV210EH(A)	AQV214EH(A)	Remarks
Input	LED forward current	I_F	A	50 mA				
	LED reverse voltage	V_R		5 V				
	Peak forward current	I_{FP}		1 A				f = 100 Hz, Duty factor = 0.1%
	Power dissipation	P_{in}		75 mW				
Output	Load voltage (peak AC)	V_L	A	350 V	400 V	350 V	400 V	
	Continuous load current	I_L	B	0.13 A	0.12 A	0.13 A	0.12 A	A connection: Peak AC, DC B, C connection: DC
			C	0.15 A	0.13 A	0.15 A	0.13 A	
				0.17 A	0.15 A	0.17 A	0.15 A	
	Peak load current	I_{peak}		0.4 A	0.3 A	0.4 A	0.3 A	A connection: 100 ms (1 shot), $V_L=DC$
	Power dissipation	P_{out}		500 mW				
Total power dissipation	P_T		550 mW					
I/O isolation voltage	V_{iso}		1,500 V AC		5,000 V AC			
Temperature limits	Operating	T_{opr}	-40°C to +85°C -40°F to +185°F				Non-condensing at low temp.	
	Storage	T_{stg}	-40°C to +100°C -40°F to +212°F					

GU-E 1 Form A (AQV210E, AQV210EH)

2. Electrical characteristics (Ambient temperature: 25°C 77°F)

Item		Symbol	Type of connection	AQV210E(A)	AQV214E(A)	AQV210EH(A)	AQV214EH(A)	Condition	
Input	LED operate current	Typical	I _{Fon}	—	1.1 mA	1.6 mA		I _L = Max.	
		Maximum			3 mA				
	LED turn off current	Minimum	I _{Foff}	—	0.3 mA	0.4 mA		I _L = Max.	
		Typical			1.0 mA	1.5 mA			
LED dropout voltage	Typical	V _F	—	1.25 V (1.14 V at I _F = 5 mA)				I _F = 50 mA	
	Maximum			1.5 V					
Output	On resistance	Typical	R _{on}	A	23 Ω	30 Ω	23 Ω	30 Ω	I _F = 5 mA I _L = Max. Within 1 s on time
		Maximum			35 Ω	50 Ω	35 Ω	50 Ω	
		Typical	R _{on}	B	11.5 Ω	22.5 Ω	11.5 Ω	22.5 Ω	I _F = 5 mA I _L = Max. Within 1 s on time
		Maximum			17.5 Ω	25 Ω	17.5 Ω	25 Ω	
	Typical	R _{on}	C	6.0 Ω	11.3 Ω	6.0 Ω	11.3 Ω	I _F = 5 mA I _L = Max. Within 1 s on time	
	Maximum			8.8 Ω	12.5 Ω	8.8 Ω	12.5 Ω		
Output capacitance	Typical	C _{out}	A	45 pF				I _F = 0 mA V _B = 0 V f = 1 MHz	
Off state leakage current	Maximum	I _{Leak}	—	1 μA				I _F = 0 mA V _L = Max.	
Transfer characteristics	Turn on time*	Typical	T _{on}	—	0.5 ms	0.7 ms		I _F = 0 mA → 5 mA** I _L = Max.	
		Maximum			2.0 ms				
	Turn off time*	Typical	T _{off}	—	0.05 ms			I _F = 0 mA → 5 mA I _L = Max.	
		Maximum			1.0 ms				
	I/O capacitance	Typical	C _{iso}	—	0.8 pF			f = 1 MHz V _B = 0 V	
Maximum		1.5 pF							
Initial I/O isolation resistance	Minimum	R _{iso}	—	1,000 MΩ			500 V DC		

*Turn on/Turn off time

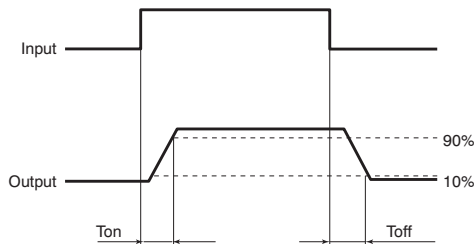

RECOMMENDED OPERATING CONDITIONS

Please obey the following conditions to ensure proper relay operation and resetting.

Item	Symbol	Recommended value	Unit
Input LED current	I _F	Standard type: 5 Reinforced type: 5 to 10	mA

■ For Dimensions, see page 60.

■ For Schematic and Wiring Diagrams, see page 65.

■ For Cautions for Use, see page 71.

■ These products are not designed for automotive use.

If you are considering to use these products for automotive applications, please contact your local Panasonic technical representative.

For more information, see page 80.

GU-E 1 Form A (AQV210E, AQV210EH)

REFERENCE DATA

1. Load current vs. ambient temperature characteristics

Allowable ambient temperature: -40°C to $+85^{\circ}\text{C}$
 -40°F to $+185^{\circ}\text{F}$

Type of connection: A

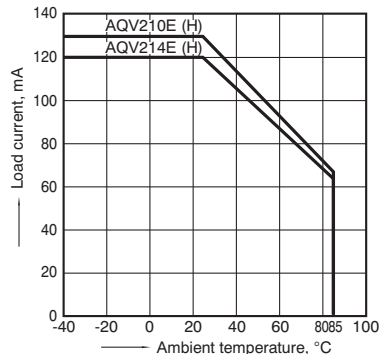

2. On-resistance vs. ambient temperature characteristics

Measured portion: between terminals 4 and 6;
 LED current: 5 mA; Load voltage: Max. (DC);
 Continuous load current: Max. (DC)

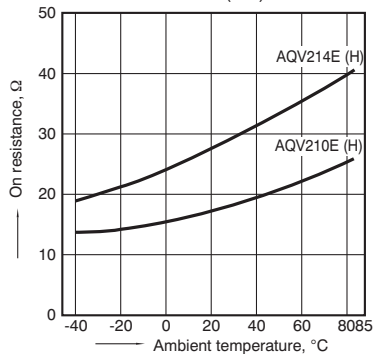

3. Turn on time vs. ambient temperature characteristics

LED current: 5 mA;
 Load voltage: Max. (DC);
 Continuous load current: Max. (DC)

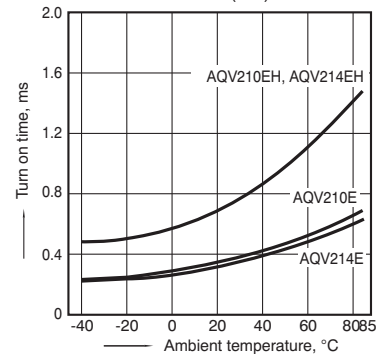

4. Turn off time vs. ambient temperature characteristics

LED current: 5 mA; Load voltage: Max. (DC);
 Continuous load current: Max. (DC)

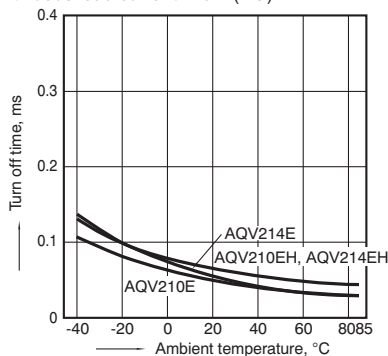

5. LED operate current vs. ambient temperature characteristics

Load voltage: Max. (DC);
 Continuous load current: Max. (DC)

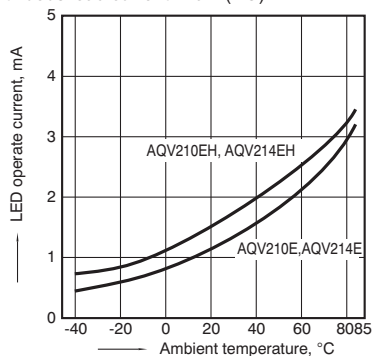

6. LED turn off current vs. ambient temperature characteristics

Load voltage: Max. (DC);
 Continuous load current: Max. (DC)

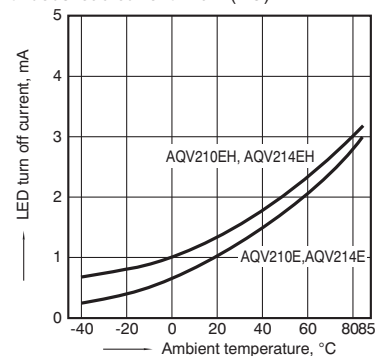

7. LED dropout voltage vs. ambient temperature characteristics

Sample: All types
 LED current: 5 to 50 mA

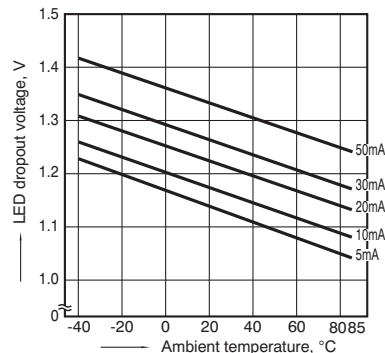

8. Current vs. voltage characteristics of output at MOS portion

Measured portion: between terminals 4 and 6;
 Ambient temperature: 25°C 77°F

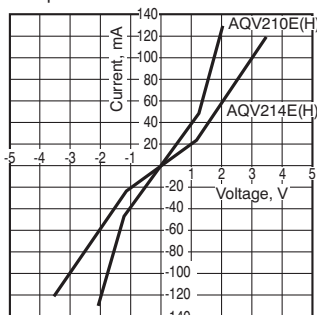

9. Off state leakage current vs. load voltage characteristics

Measured portion: between terminals 4 and 6;
 Ambient temperature: 25°C 77°F

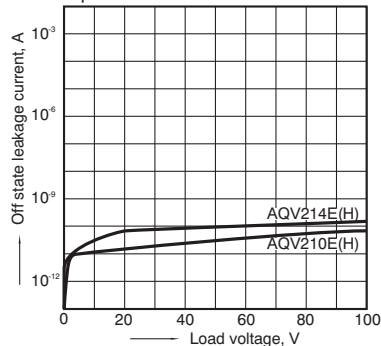

GU-E 1 Form A (AQV210E, AQV210EH)

10-(1). Turn on time vs. LED forward current characteristics

Measured portion: between terminals 4 and 6;
Load voltage: Max. (DC); Continuous load current:
Max. (DC); Ambient temperature: 25°C 77°F

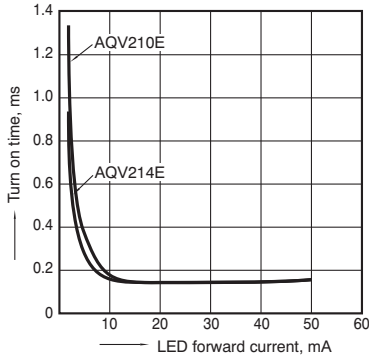

10-(2). Turn on time vs. LED forward current characteristics

Measured portion: between terminals 4 and 6;
Load voltage: Max. (DC); Continuous load current:
Max. (DC); Ambient temperature: 25°C 77°F

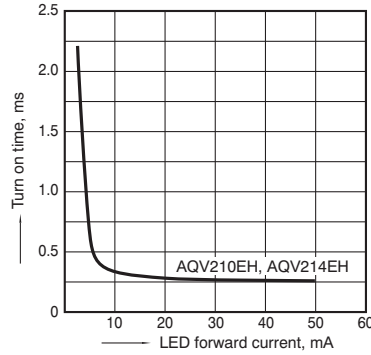

11-(1). Turn off time vs. LED forward current characteristics

Measured portion: between terminals 4 and 6;
Load voltage: Max. (DC); Continuous load current:
Max. (DC); Ambient temperature: 25°C 77°F

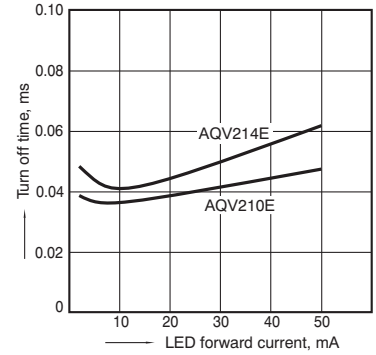

11-(2). Turn off time vs. LED forward current characteristics

Measured portion: between terminals 4 and 6;
Load voltage: Max. (DC); Continuous load current:
Max. (DC); Ambient temperature: 25°C 77°F

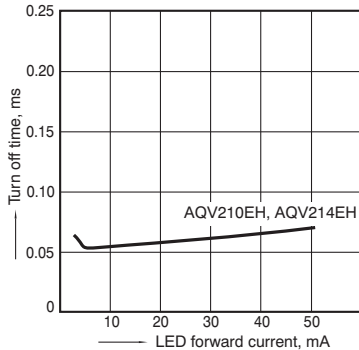

12. Output capacitance vs. applied voltage characteristics

Measured portion: between terminals 4 and 6;
Frequency: 1 MHz;
Ambient temperature: 25°C 77°F

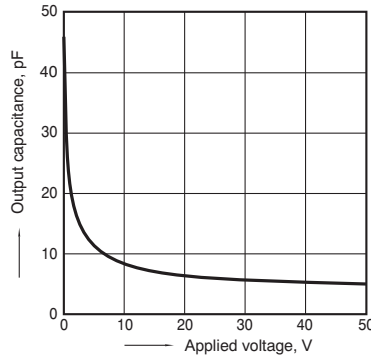

Panasonic

ideas for life



High cost-performance
DIP8-pin type with
reinforced insulation

PhotoMOS®
GU-E 2 Form A
(AQW210EH)

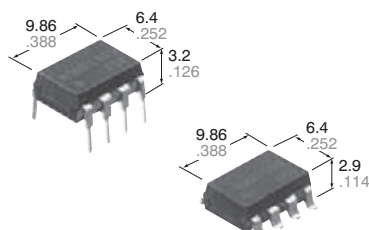

CAD Data

mm inch

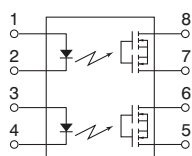

FEATURES

- 1. Reinforced insulation of 5,000 V**
More than 0.4 mm internal insulation distance between inputs and outputs. Con-forms to EN41003, EN60950 (reinforced insulation).
- 2. Applicable for 2 Form A use as well as two independent 1 Form A use**
- 3. Controls low-level analog signals**
PhotoMOS relays feature extremely low closed-circuit offset voltage to enable control of low-level analog signals without distortion.
- 4. High sensitivity and high speed response**
Can control max. 0.14 A load current with 5 mA input current. Fast operation speed of typ. 0.5 ms (AQW210EH).
- 5. Low-level off state leakage current of max. 1 μ A**

TYPICAL APPLICATIONS

- Modem
- Telephone equipment
- Security equipment
- Sensing equipment

TYPES

	I/O isolation voltage	Output rating*		Package	Part No.				Packing quantity	
					Through hole terminal	Surface-mount terminal		Tube	Tape and reel	
						Tape and reel packing style				
					Tube packing style	Picked from the 1/2/3/4-pin side	Picked from the 5/6/7/8-pin side			
AC/DC dual use	Reinforced 5,000 V	60 V	500 mA	DIP8-pin	AQW212EH	AQW212EHA	AQW212EHAX	AQW212EHAZ	1 tube contains: 50 pcs. 1 batch contains: 500 pcs.	1,000 pcs.
		350 V	120 mA		AQW210EH	AQW210EHA	AQW210EHAX	AQW210EHAZ		
		400 V	100 mA		AQW214EH	AQW214EHA	AQW214EHAX	AQW214EHAZ		
		600 V	40 mA		AQW216EH	AQW216EHA	AQW216EHAX	AQW216EHAZ		

*Indicate the peak AC and DC values.

Note: The surface mount terminal shape indicator "A" and the packing style indicator "X" or "Z" are not marked on the relay.

RATING

1. Absolute maximum ratings (Ambient temperature: 25°C 77°F)

Item		Symbol	AQW212EH(A)	AQW210EH(A)	AQW214EH(A)	AQW216EH(A)	Remarks
Input	LED forward current	I_F	50mA				
	LED reverse voltage	V_R	5V				
	Peak forward current	I_{FP}	1A				f = 100 Hz, Duty factor = 0.1%
	Power dissipation	P_{in}	75mW				
Output	Load voltage (peak AC)	V_L	60 V	350 V	400 V	600 V	
	Continuous load current	I_L	0.5 A (0.6 A)	0.12 A (0.14 A)	0.1 A (0.13 A)	0.04 A (0.05 A)	Peak AC, DC (): in case of using only 1 channel
	Peak load current	I_{peak}	1.5 A	0.36 A	0.3 A	0.15 A	100 ms (1 shot), $V_L = DC$
	Power dissipation	P_{out}	800mW				
Total power dissipation		P_T	850mW				
I/O isolation voltage		V_{iso}	5,000 V AC				
Temperature limits	Operating	T_{opr}	-40°C to +85°C -40°F to +185°F				Non-condensing at low temperatures
	Storage	T_{stg}	-40°C to +100°C -40°F to +212°F				

GU-E 2 Form A (AQW210EH)

2. Electrical characteristics (Ambient temperature: 25°C 77°F)

Item			Symbol	AQW212EH(A)	AQW210EH(A)	AQW214EH(A)	AQW216EH(A)	Condition
Input	LED operate current	Typical	I_{Fon}	1.2mA				$I_L=Max.$
		Maximum		3.0mA				
	LED turn off current	Minimum	I_{Foff}	0.4mA				$I_L=Max.$
		Typical		1.1mA				
LED dropout voltage	Typical	V_F	1.25 V (1.14 V at $I_F=5mA$)				$I_F=50mA$	
	Maximum		1.5V					
Output	On resistance	Typical	R_{on}	0.83Ω	18Ω	26Ω	52Ω	$I_F=5mA$ $I_L=Max.$ Within 1 s on time
		Maximum		2.5Ω	25Ω	35Ω	120Ω	
	Off state leakage current	Maximum	I_{Leak}	1μA				$I_F=0mA$ $V_L=Max.$
Transfer characteristics	Turn on time*	Typical	T_{on}	1ms	0.5ms			$I_F=5mA$ $I_L=Max.$
		Maximum		4ms	2.0ms			
	Turn off time*	Typical	T_{off}	0.08ms				$I_F=5mA$ $I_L=Max.$
		Maximum		1.0ms				
	I/O capacitance	Typical	C_{iso}	0.8pF				$f=1MHz$ $V_B=0V$
		Maximum		1.5pF				
Initial I/O isolation resistance	Minimum	R_{iso}	1,000MΩ				500V DC	

*Turn on/Turn off time

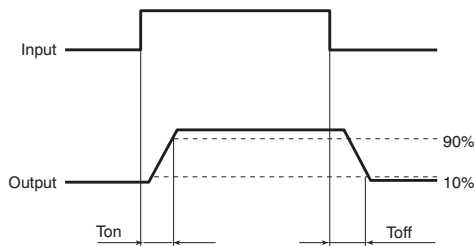

RECOMMENDED OPERATING CONDITIONS

Please obey the following conditions to ensure proper relay operation and resetting.

Item	Symbol	Recommended value	Unit
Input LED current	I_F	5 to 10	mA

■ For Dimensions, see page 61.

■ For Schematic and Wiring Diagrams, see page 65.

■ For Cautions for Use, see page 71.

■ These products are not designed for automotive use.

If you are considering to use these products for automotive applications, please contact your local Panasonic technical representative.

For more information, see page 80.

REFERENCE DATA

1-(1). Load current vs. ambient temperature characteristics

Allowable ambient temperature: -20°C to +85°C
-4°F to +185°F

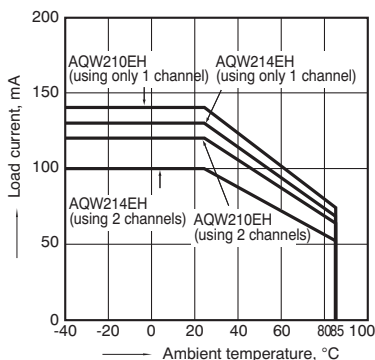

1-(2). Load current vs. ambient temperature characteristics

Allowable ambient temperature: -40°C to +85°C
-40°F to +185°F

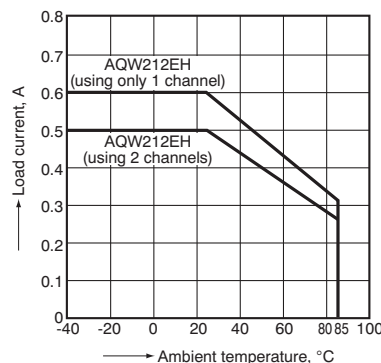

1-(3). Load current vs. ambient temperature characteristics

Allowable ambient temperature: -40°C to +85°C
-40°F to +185°F

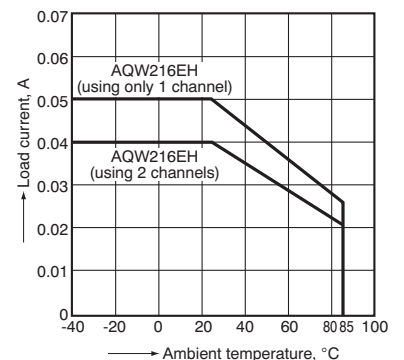

GU-E 2 Form A (AQW21EH)

2-(1). On resistance vs. ambient temperature characteristics

Measured portion: between terminals 5 and 6, 7 and 8;
LED current: 5 mA; Load voltage: Max. (DC);
Continuous load current: Max. (DC)

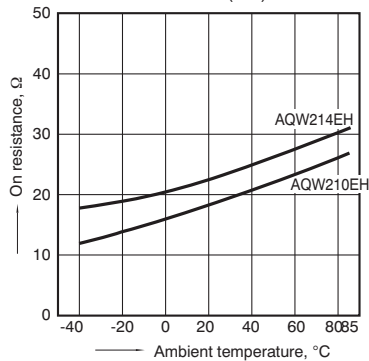

2-(2). On resistance vs. ambient temperature characteristics

Measured portion: between terminals 5 and 6, 7 and 8;
LED current: 5 mA; Load voltage: Max. (DC);
Continuous load current: Max. (DC)

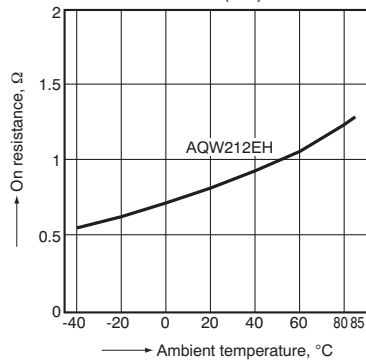

2-(3). On resistance vs. ambient temperature characteristics

Measured portion: between terminals 5 and 6, 7 and 8;
LED current: 5 mA; Load voltage: Max. (DC);
Continuous load current: Max. (DC)

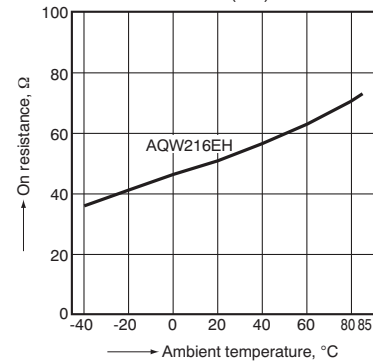

3. Turn on time vs. ambient temperature characteristics

Sample: All types
LED current: 5 mA; Load voltage: Max. (DC);
Continuous load current: Max. (DC)

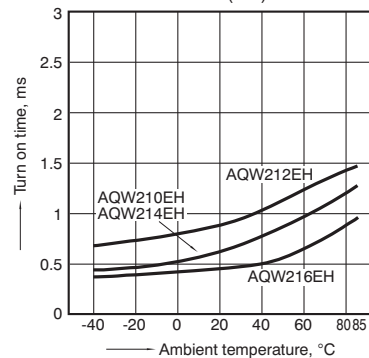

4. Turn off time vs. ambient temperature characteristics

Sample: All types
LED current: 5 mA; Load voltage: Max. (DC);
Continuous load current: Max. (DC)

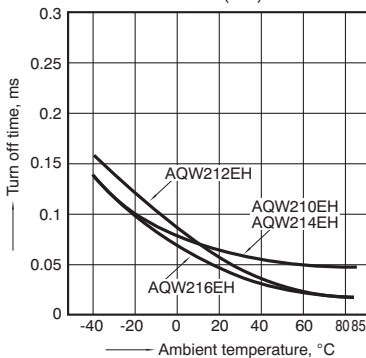

5. LED operate current vs. ambient temperature characteristics

Sample: All types; Load voltage: Max. (DC);
Continuous load current: Max. (DC)

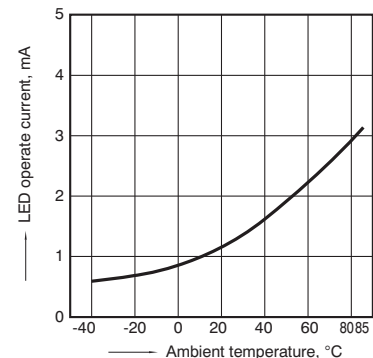

6. LED turn off current vs. ambient temperature characteristics

Sample: All types; Load voltage: Max. (DC);
Continuous load current: Max. (DC)

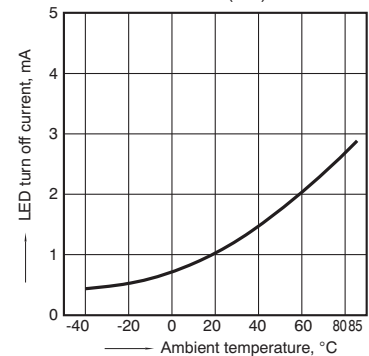

7. LED dropout voltage vs. ambient temperature characteristics

Sample: All types; LED current: 5 to 50 mA

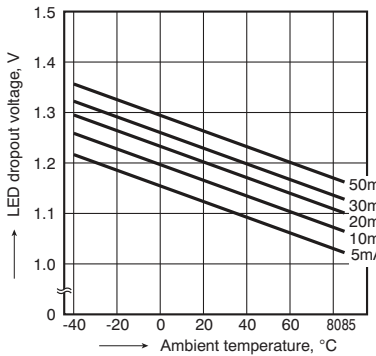

8-(1). Current vs. voltage characteristics of output at MOS portion

Measured portion: between terminals 5 and 6, 7 and 8;
Ambient temperature: 25°C 77°F

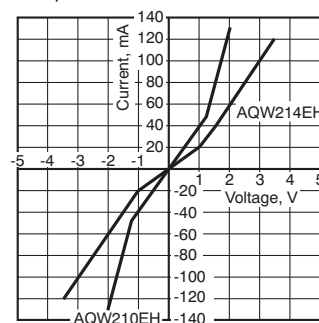

8-(2). Current vs. voltage characteristics of output at MOS portion

Measured portion: between terminals 3 and 4;
Ambient temperature: 25°C 77°F

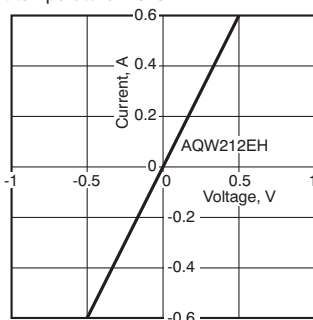

8-(3). Current vs. voltage characteristics of output at MOS portion

Measured portion: between terminals 3 and 4;
Ambient temperature: 25°C 77°F

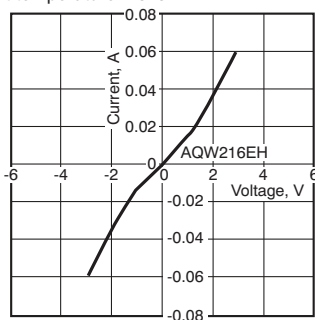

9-(1). Off state leakage current vs. load voltage characteristics

Measured portion: between terminals 5 and 6, 7 and 8;
Ambient temperature: 25°C 77°F

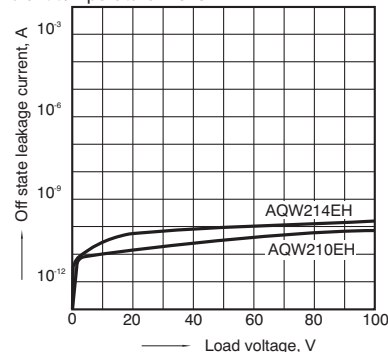

GU-E 2 Form A (AQW210EH)

9-(2). Off state leakage current vs. load voltage characteristics

Measured portion: between terminals 5 and 6, 7 and 8;
Ambient temperature: 25°C 77°F

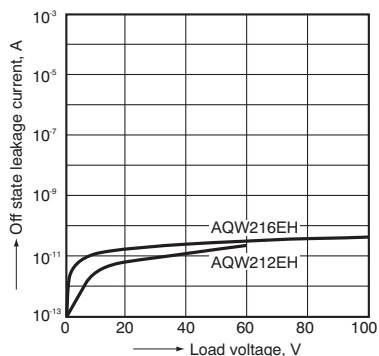

10. Turn on time vs. LED forward current characteristics

Sample: All types
Measured portion: between terminals 5 and 6, 7 and 8;
Load voltage: Max. (DC); Continuous load current: Max. (DC); Ambient temperature: 25°C 77°F

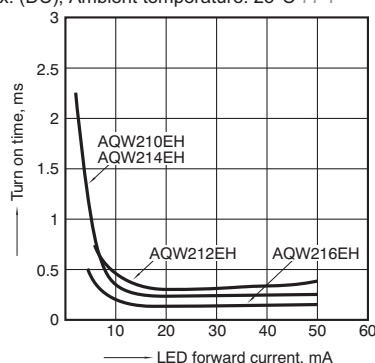

11. Turn off time vs. LED forward current characteristics

Sample: All types
Measured portion: between terminals 5 and 6, 7 and 8;
Load voltage: Max. (DC); Continuous load current: Max. (DC); Ambient temperature: 25°C 77°F

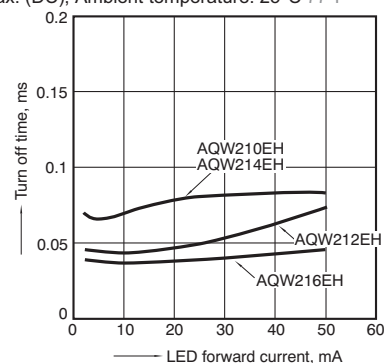

12-(1). Output capacitance vs. applied voltage characteristics

Measured portion: between terminals 5 and 6, 7 and 8;
Frequency: 1 MHz; Ambient temperature: 25°C 77°F

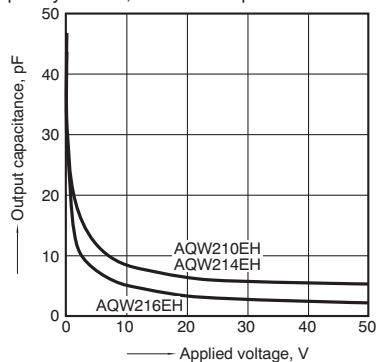

12-(2). Output capacitance vs. applied voltage characteristics

Measured portion: between terminals 5 and 6, 7 and 8;
Frequency: 1 MHz; Ambient temperature: 25°C 77°F

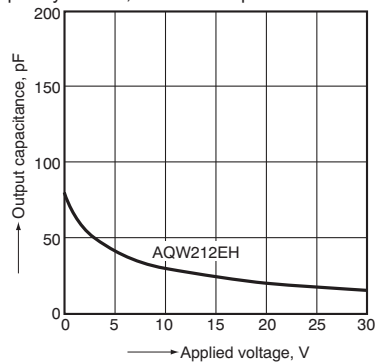

PhotoMOS

Panasonic

ideas for life



Normally closed DIP4-pin
economic type with
reinforced insulation

PhotoMOS[®]
GU-E 1 Form B
(AQY410EH)

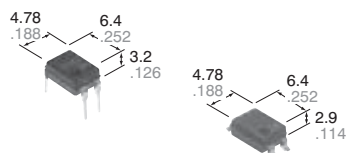

CAD Data

mm inch

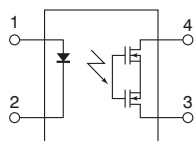

FEATURES

1. High cost-performance type of PhotoMOS relay 1 Form B output

2. Low on-resistance

This has been realized thanks to the built-in MOSFET processed by our proprietary method, DSD (Double-diffused and Selective Doping) method.

4. Controls low-level analog signals

PhotoMOS relays feature extremely low closed-circuit offset voltage to enable control of low-level analog signals without distortion.

5. High sensitivity and low on-resistance

Can control max. 0.55 A load current with 5 mA input current.

Low on-resistance of typ. 1Ω (AQY412EH).

6. Low-level off-state leakage current

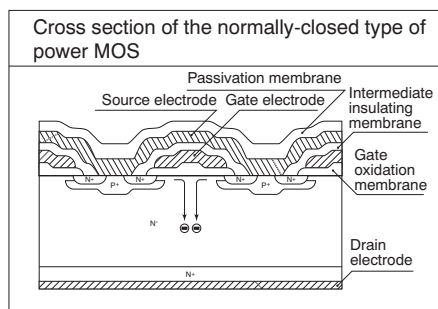

3. Reinforced insulation of 5,000 V

More than 0.4 mm internal insulation distance between inputs and outputs. Conforms to EN41003, EN60950 (reinforced insulation).

TYPICAL APPLICATIONS

- Power supply
- Measuring equipment
- Security equipment
- Modem
- Telephone equipment
- Electricity, plant equipment
- Sensing equipment

TYPES

Type	I/O isolation voltage	Output rating*		Package	Part No.				Packing quantity	
		Load voltage	Load current		Through hole terminal	Surface-mount terminal		Tube	Tape and reel	
						Tape and reel packing style				
				Tube packing style		Picked from the 1/2-pin side	Picked from the 3/4-pin side			
AC/DC dual use	Reinforced 5,000 V	60 V	550 mA	DIP4-pin	AQY412EH	AQY412EHA	AQY412EHAX	AQY412EHAZ	1 tube contains: 100 pcs. 1 batch contains: 1,000 pcs.	1,000 pcs.
		350 V	130 mA		AQY410EH	AQY410EHA	AQY410EHAX	AQY410EHAZ		
		400 V	120 mA		AQY414EH	AQY414EHA	AQY414EHAX	AQY414EHAZ		

*Indicate the peak AC and DC values.

Note: For space reasons, the initial letters of the part number "AQY", the surface mount terminal shape indicator "A" and the packing style indicator "X" or "Z" are not marked on the relay. (Ex. the label for product number AQY412EHAX is 412EH.)

RATING

1. Absolute maximum ratings (Ambient temperature: 25°C 77°F)

Item		Symbol	AQY412EH(A)	AQY410EH(A)	AQY414EH(A)	Remarks
Input	LED forward current	I _F	50 mA			
	LED reverse voltage	V _R	5 V			
	Peak forward current	I _{FP}	1 A			f = 100 Hz, Duty factor = 0.1%
	Power dissipation	P _{in}	75 mW			
Output	Load voltage (peak AC)	V _L	60 V	350 V	400 V	
	Continuous load current	I _L	0.55 A	0.13 A	0.12 A	Peak AC, DC
	Peak load current	I _{peak}	1.5 A	0.4 A	0.3 A	100 ms (1 shot), V _L = DC
	Power dissipation	P _{out}	500 mW			
Total power dissipation		P _T	550 mW			
I/O isolation voltage		V _{iso}	5,000 V AC			
Temperature limits	Operating	T _{opr}	-40°C to +85°C -40°F to +185°F			Non-condensing at low temperatures
	Storage	T _{stg}	-40°C to +100°C -40°F to +212°F			

GU-E 1 Form B (AQY41○EH)

2. Electrical characteristics (Ambient temperature: 25°C 77°F)

Item			Symbol	AQY412EH(A)	AQY410EH(A)	AQY414EH(A)	Condition
Input	LED operate (OFF) current	Typical	I_{Foff}	1.4 mA			$I_L = \text{Max.}$
		Maximum		3.0 mA			
	LED reverse (ON) current	Minimum	I_{Fon}	0.4 mA			$I_L = \text{Max.}$
		Typical		1.3 mA			
LED dropout voltage	Typical	V_F	1.25 (1.14 V at $I_F = 5 \text{ mA}$)			$I_F = 50 \text{ mA}$	
	Maximum		1.5 V				
Output	On resistance	Typical	R_{on}	1Ω	18Ω	26Ω	$I_F = 0 \text{ mA}$ $I_L = \text{Max.}$ Within 1 s on time
		Maximum		2.5Ω	25Ω	35Ω	
	Off state leakage current	Maximum	I_{Leak}	10μA			$I_F = 5 \text{ mA}$ $V_L = \text{Max.}$
Transfer characteristics	Operate (OFF) time*	Typical	T_{off}	3.0 ms	1.0 ms	0.8 ms	$I_F = 0 \text{ mA} \rightarrow 5 \text{ mA}$ $I_L = \text{Max.}$
		Maximum		10.0 ms			
	Reverse (ON) time*	Typical	T_{on}	0.2 ms	0.3 ms	0.2 ms	$I_F = 5 \text{ mA} \rightarrow 0 \text{ mA}$ $I_L = \text{Max.}$
		Maximum		1.0 ms			
	I/O capacitance	Typical	C_{iso}	0.8 pF			$f = 1 \text{ MHz}$ $V_B = 0 \text{ V}$
Maximum		1.5 pF					
Initial I/O isolation resistance	Minimum	R_{iso}	1,000MΩ			500 V DC	

*Operate/Reverse time

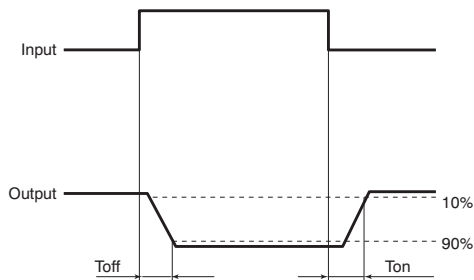

RECOMMENDED OPERATING CONDITIONS

Please obey the following conditions to ensure proper relay operation and resetting.

Item	Symbol	Recommended value	Unit
Input LED current	I_F	5 to 10	mA

- For Dimensions, see page 60.
- For Schematic and Wiring Diagrams, see page 65.
- For Cautions for Use, see page 71.
- These products are not designed for automotive use.

If you are considering to use these products for automotive applications, please contact your local Panasonic technical representative.

For more information, see page 80.

REFERENCE DATA

1-(1). Load current vs. ambient temperature characteristics

Allowable ambient temperature: -40°C to +85°C
-40°F to +185°F

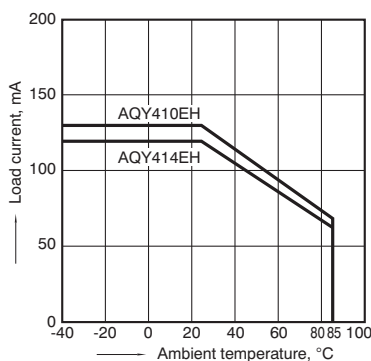

1-(2). Load current vs. ambient temperature characteristics

Allowable ambient temperature: -40°C to +85°C
-40°F to +185°F

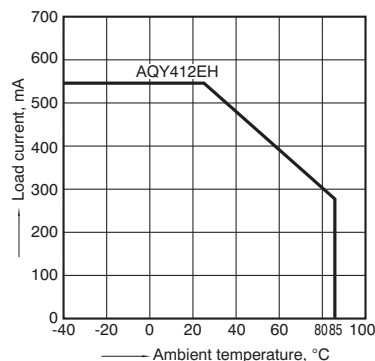

2. On resistance vs. ambient temperature characteristics

Measured portion: between terminals 3 and 4;
LED current: 0 mA; Load voltage: Max.(DC);
Continuous load current: Max. (DC)

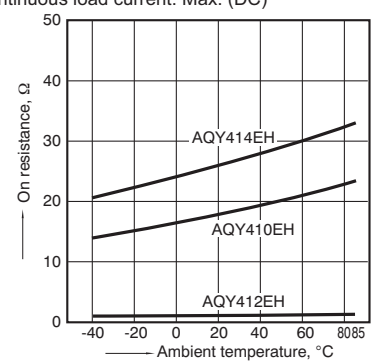

GU-E 1 Form B (AQY410EH)

3. Operate (OFF) time vs. ambient temperature characteristics

LED current: 5 mA; Load voltage: Max. (DC);
Continuous load current: Max. (DC)

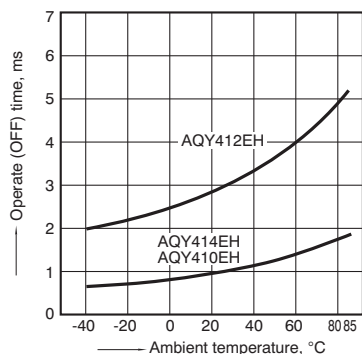

4. Reverse (ON) time vs. ambient temperature characteristics

LED current: 5 mA; Load voltage: Max. (DC);
Continuous load current: Max. (DC)

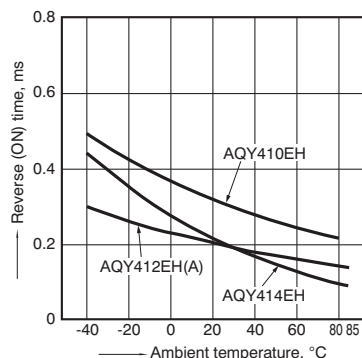

5. LED operate (OFF) current vs. ambient temperature characteristics

Sample: All types;
Load voltage: Max. (DC);
Continuous load current: Max. (DC)

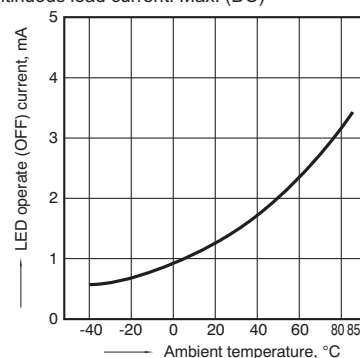

6. LED reverse (ON) current vs. ambient temperature characteristics

Sample: All types;
Load voltage: Max. (DC);
Continuous load current: Max. (DC)

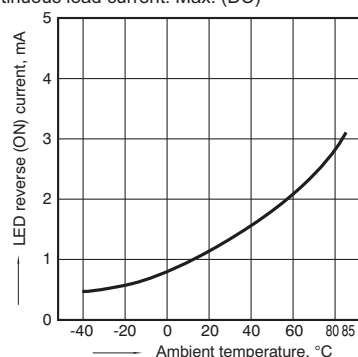

7. LED dropout voltage vs. ambient temperature characteristics

LED current: 5 to 50 mA

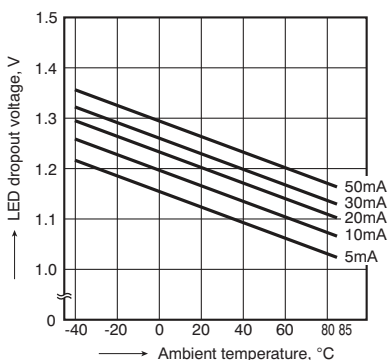

8-(1). Current vs. voltage characteristics of output at MOS portion

Measured portion: between terminals 3 and 4;
Ambient temperature: 25°C 77°F

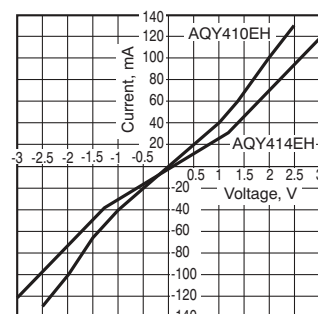

8-(2). Current vs. voltage characteristics of output at MOS portion

Measured portion: between terminals 3 and 4;
Ambient temperature: 25°C 77°F

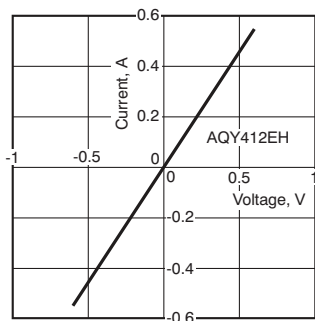

9. Off state leakage current vs. load voltage characteristics

Measured portion: between terminals 3 and 4;
Ambient temperature: 25°C 77°F

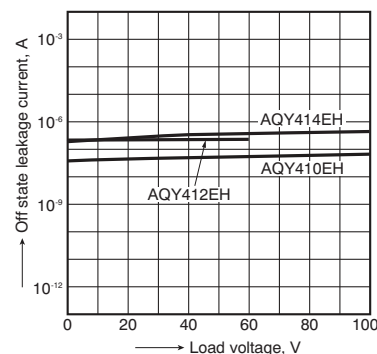

10. Operate (OFF) time vs. LED forward current characteristics

Measured portion: between terminals 3 and 4;
Load voltage: Max. (DC); Continuous load current: Max. (DC); Ambient temperature: 25°C 77°F

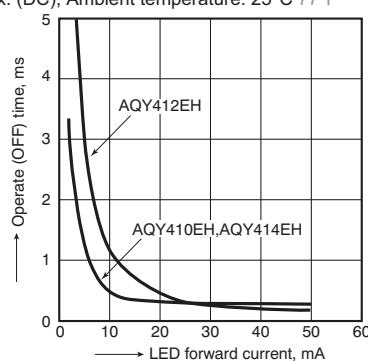

11. Reverse (ON) time vs. LED forward current characteristics

Measured portion: between terminals 3 and 4;
Load voltage: Max. (DC); Continuous load current: Max. (DC); Ambient temperature: 25°C 77°F

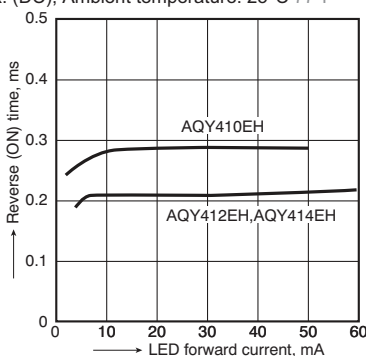

12. Output capacitance vs. applied voltage characteristics

Measured portion: between terminals 3 and 4;
Frequency: 1 MHz; Ambient temperature: 25°C 77°F

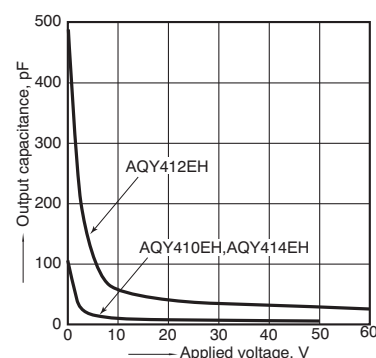

Panasonic

ideas for life



Normally closed DIP6-pin
economic type with
reinforced insulation

PhotoMOS®
GU-E 1 Form B
(AQV414E, AQV410EH)

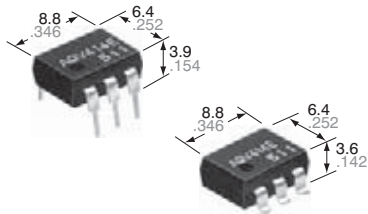

CAD Data

mm inch

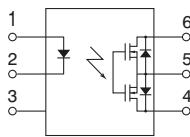

FEATURES

1. High cost-performance type of PhotoMOS 1 Form B output
2. 60V type couples high capacity (0.55A) with low on-resistance (typ. 1Ω).
3. Low on-resistance

This has been realized thanks to the built-in MOSFET processed by our proprietary method, DSD (Double-diffused and Selective Doping) method.

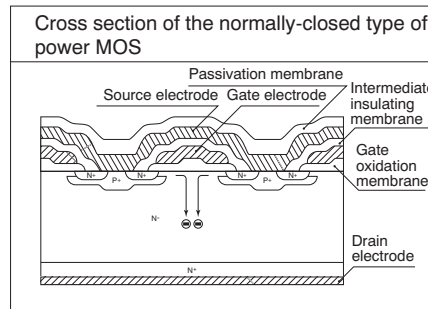

4. Controls low-level analog signals
- PhotoMOS relays feature extremely low closed-circuit offset voltage to enable control of low-level analog signals without distortion.

5. High sensitivity and low on-resistance

Can control max. 0.55 A load current with 5 mA input current.

Low on-resistance of typ. 1Ω (AQV412EH).

6. Low-level off-state leakage current of max. 1 μA (AQV414E)

7. Reinforced insulation 5,000 V type also available

More than 0.4 mm internal insulation distance between inputs and outputs. Conforms to EN41003, EN60950 (reinforced insulation).

TYPICAL APPLICATIONS

- Power supply
- Measuring equipment
- Security equipment
- Telephone equipment
- Sensing equipment

TYPES

	I/O isolation voltage	Output rating*		Package	Part No.				Packing quantity	
		Load voltage	Load current		Through hole terminal	Surface-mount terminal			Tube	Tape and reel
						Tape and reel packing style				
				Tube packing style	Picked from the 1/2/3-pin side	Picked from the 4/5/6-pin side				
AC/DC dual use	1,500 V AC (Standard)	400 V	120 mA	DIP6-pin	AQV414E	AQV414EA	AQV414EAX	AQV414EAZ	1 tube contains: 50 pcs. 1 batch contains: 500 pcs.	1,000 pcs.
		60 V	550 mA		AQV412EH	AQV412EHA	AQV412EHAX	AQV412EHAZ		
	5,000 V AC (Reinforced)	350 V	130 mA		AQV410EH	AQV410EHA	AQV410EHAX	AQV410EHAZ		
		400 V	120 mA		AQV414EH	AQV414EHA	AQV414EHAX	AQV414EHAZ		

*Indicate the peak AC and DC values.

Note: The surface mount terminal shape indicator "A" and the packing style indicator "X" or "Z" are not marked on the relay.

RATING

1. Absolute maximum ratings (Ambient temperature: 25°C 77°F)

Item	Symbol	Type of connection	AQV414E(A)	AQV412EH(A)	AQV410EH(A)	AQV414EH(A)	Remarks		
Input	LED forward current	I _F	50 mA						
	LED reverse voltage	V _R	5 V						
	Peak forward current	I _{FP}	1 A				f = 100 Hz, Duty factor = 0.1%		
	Power dissipation	P _{in}	75 mW						
Output	Load voltage (peak AC)	V _L	400 V	60 V	350 V	400 V			
	Continuous load current	I _L	A	0.12 A	0.55 A	0.13 A	0.12 A	A connection: Peak AC, DC B,C connection: DC	
			B	0.13 A	0.65 A	0.15 A	0.13 A		
			C	0.15 A	0.8 A	0.17 A	0.15 A		
	Peak load current	I _{peak}	0.3 A				1.5 A	0.4 A	0.3 A
Power dissipation	P _{out}	500 mW							
Total power dissipation	P _T	550 mW							
I/O isolation voltage	V _{iso}	1,500 V AC		5,000 V AC					
Temperature limits	Operating	T _{opr}	-40°C to +85°C -40°F to +185°F				Non-condensing at low temperatures		
	Storage	T _{stg}	-40°C to +100°C -40°F to +212°F						

GU-E 1 Form B (AQV414E, AQV410EH)

2. Electrical characteristics (Ambient temperature: 25°C 77°F)

Item		Symbol	Type of connection	AQV414E(A)	AQV412EH(A)	AQV410EH(A)	AQV414EH(A)	Condition	
Input	LED operate (OFF) current	Typical	—	1.45 mA	1.9 mA			$I_L = \text{Max.}$	
		Maximum		3.0 mA					
	LED reverse (ON) current	Minimum	—	0.3 mA	0.4 mA			$I_L = \text{Max.}$	
		Typical		1.40 mA	1.8 mA				
LED dropout voltage	Typical	V_F	—	1.25 V (1.14 V at $I_F = 5 \text{ mA}$)				$I_F = 50 \text{ mA}$	
	Maximum			1.5 V					
Output	On resistance	Typical	R_{on}	A	26 Ω	1 Ω	18 Ω	25.2 Ω	$I_F = 0 \text{ mA}$ $I_L = \text{Max.}$ Within 1 s on time
		Maximum			50 Ω	2.5 Ω	35 Ω	50 Ω	
		Typical	R_{on}	B	20 Ω	0.55 Ω	13 Ω	19 Ω	$I_F = 0 \text{ mA}$ $I_L = \text{Max.}$ Within 1 s on time
		Maximum			25 Ω	1.3 Ω	17.5 Ω	25 Ω	
	Typical	R_{on}	C	10 Ω	0.3 Ω	6.5 Ω	10 Ω	$I_F = 0 \text{ mA}$ $I_L = \text{Max.}$ Within 1 s on time	
	Maximum			12.5 Ω	0.7 Ω	8.8 Ω	12.5 Ω		
Off state leakage current	Maximum	I_{Leak}	—	1 μA	10 μA			$I_F = 5 \text{ mA}$ $V_L = \text{Max.}$	
Transfer characteristics	Operate (OFF) time*	Typical	T_{off}	—	0.7 ms	3 ms	1.5 ms	1.3 ms	$I_F = 0 \text{ mA} \rightarrow 5 \text{ mA}$ $I_L = \text{Max.}$
		Maximum			2.0 ms	8 ms	3.0 ms		
	Reverse (ON) time*	Typical	T_{on}	—	0.1 ms	0.3 ms			$I_F = 5 \text{ mA} \rightarrow 0 \text{ mA}$ $I_L = \text{Max.}$
		Maximum			1.0 ms	1.5 ms			
	I/O capacitance	Typical	C_{iso}	—	0.8 pF				$f = 1 \text{ MHz}$ $V_B = 0 \text{ V}$
Maximum		1.5 pF							
Initial I/O isolation resistance	Minimum	R_{iso}	—	1,000 M Ω				500 V DC	

*Operate/Reverse time

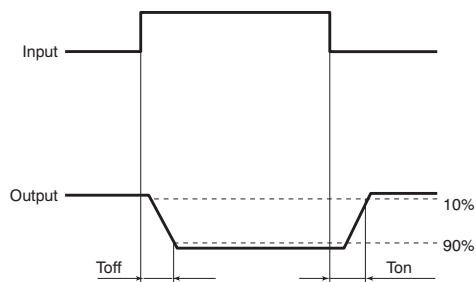

RECOMMENDED OPERATING CONDITIONS

Please obey the following conditions to ensure proper relay operation and resetting.

Item	Symbol	Recommended value	Unit
Input LED current	I_F	Standard type: 5 Reinforced type: 5 to 10	mA

■ For Dimensions, see page 60.

■ For Schematic and Wiring Diagrams, see page 66.

■ For Cautions for Use, see page 71.

■ These products are not designed for automotive use.

If you are considering to use these products for automotive applications, please contact your local Panasonic technical representative.

For more information, see page 80.

GU-E 1 Form B (AQV414E, AQV410EH)

REFERENCE DATA

13-(1). Load current vs. ambient temperature characteristics

Allowable ambient temperature: -40°C to +85°C
-40°F to +185°F

Type of connection: A

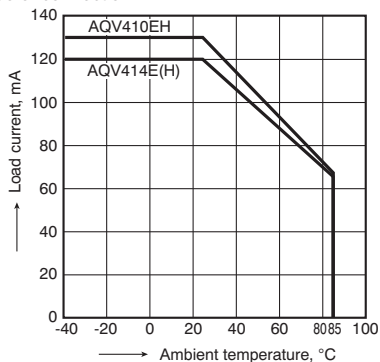

1-(2). Load current vs. ambient temperature characteristics

Allowable ambient temperature: -40°C to +85°C
-40°F to +185°F

Type of connection: A

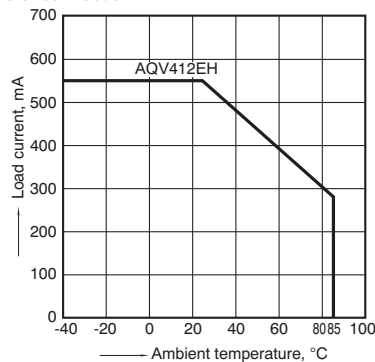

14. On resistance vs. ambient temperature characteristics

Measured portion: between terminals 4 and 6;
LED current: 0 mA; Load voltage: Max. (DC);
Continuous load current: Max. (DC)

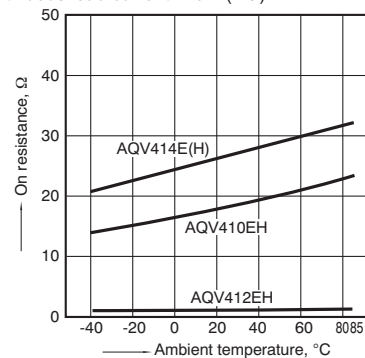

15. Operate (OFF) time vs. ambient temperature characteristics

LED current: 5mA; Load voltage: Max. (DC);
Continuous load current: Max. (DC)

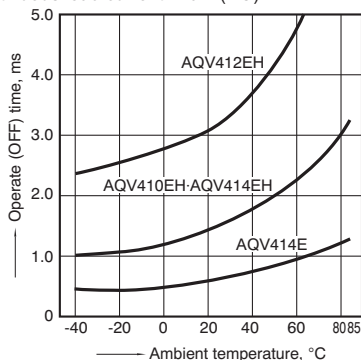

16. Reverse (ON) time vs. ambient temperature characteristics

LED current: 5 mA; Load voltage: Max. (DC);
Continuous load current: Max. (DC)

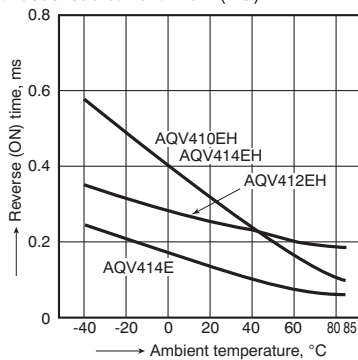

17. LED operate (OFF) current vs. ambient temperature characteristics

Load voltage: Max. (DC);
Continuous load current: Max. (DC)

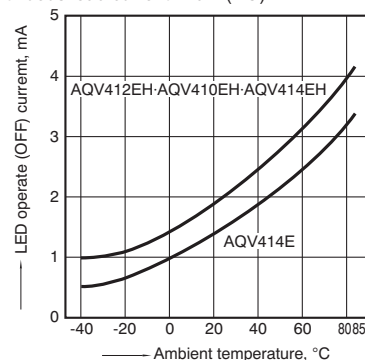

18. LED reverse (ON) current vs. ambient temperature characteristics

Load voltage: Max. (DC);
Continuous load current: Max. (DC)

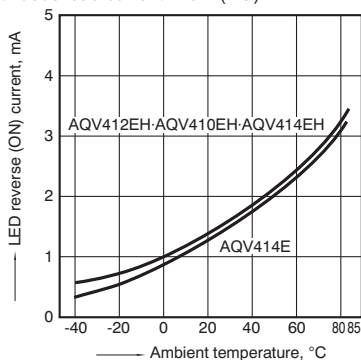

19. LED dropout voltage vs. ambient temperature characteristics

Sample: All types;
LED current: 5 to 50 mA

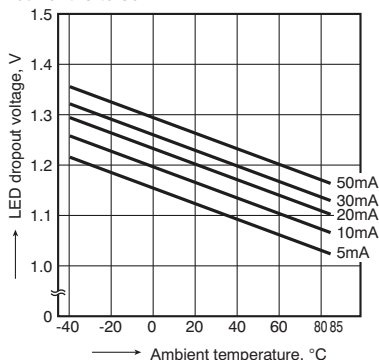

20-(1). Current vs. voltage characteristics of output at MOS portion

Measured portion: between terminals 4 and 6;
Ambient temperature: 25°C 77°F

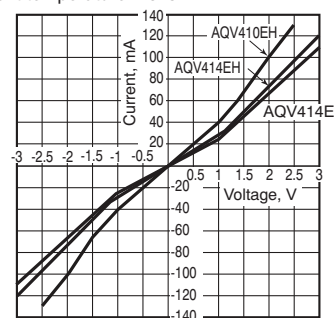

GU-E 1 Form B (AQV414E, AQV410EH)

8-(2). Current vs. voltage characteristics of output at MOS portion

Measured portion: between terminals 4 and 6;
Ambient temperature: 25°C 77°F

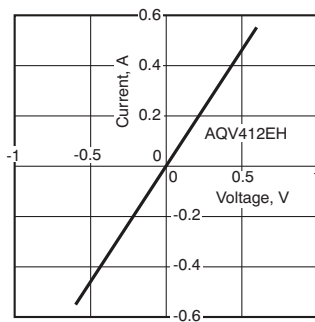

21. Off state leakage current vs. load voltage characteristics

Sample: All types;
Measured portion: between terminals 4 and 6;
LED current: 5 mA; Ambient temperature: 25°C 77°F

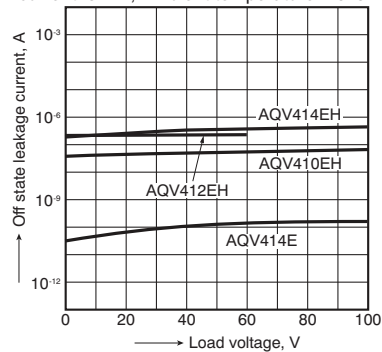

22. Operate (OFF) time vs. LED forward current characteristics

Measured portion: between terminals 4 and 6;
Load voltage: Max. (DC); Continuous load current: Max. (DC); Ambient temperature: 25°C 77°F

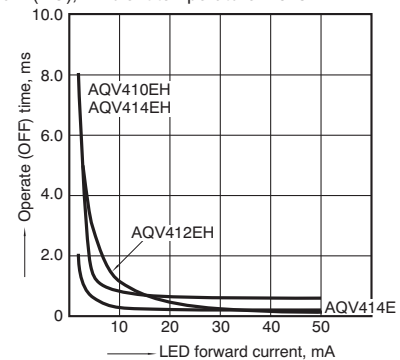

23. Reverse (ON) time vs. LED forward current characteristics

Measured portion: between terminals 4 and 6;
Load voltage: Max. (DC); Continuous load current: Max. (DC); Ambient temperature: 25°C 77°F

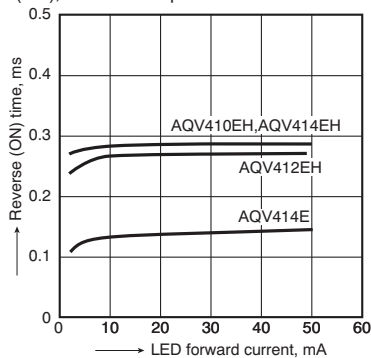

24. Output capacitance vs. applied voltage characteristics

Measured portion: between terminals 4 and 6;
Frequency: 1 MHz;
Ambient temperature: 25°C 77°F

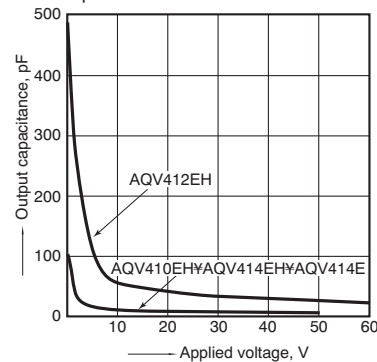

Panasonic

ideas for life



Normally closed DIP8-pin
economic type with
reinforced insulation

PhotoMOS[®]
GU-E 2 Form B
(AQW414EH)

PhotoMOS

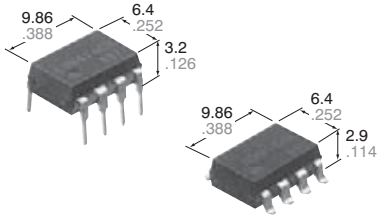

CAD Data

mm inch

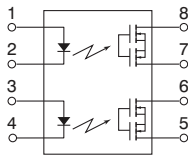

FEATURES

1. Reinforced insulation of 5,000 V
More than 0.4 mm internal insulation distance between inputs and outputs. Con-forms to EN41003, EN60950 (reinforced insulation).

2. Applicable for 2 Form B use as well as two independent 1 Form B use

3. Controls low-level analog signals
PhotoMOS relays feature extremely low closed-circuit offset voltage to enable control of low-level analog signals without distortion.

4. High sensitivity and high speed response

Can control max. 0.13 A load current with 5 mA input current. Fast operation speed of typ. 0.8 ms.

5. Low-level off state leakage current

TYPICAL APPLICATIONS

- Modem
- Telephone equipment
- Security equipment
- Sensing equipment

TYPES

	I/O isolation voltage	Output rating*		Package	Part No.				Packing quantity	
		Load voltage	Load current		Through hole terminal	Surface-mount terminal		Tube	Tape and reel	
						Tape and reel packing style				
					Tube packing style	Picked from the 1/2/3/4-pin side	Picked from the 5/6/7/8-pin side			
AC/DC dual use	Reinforced 5,000 V	400 V	100 mA	DIP8-pin	AQW414EH	AQW414EHA	AQW414EHAX	AQW414EHAZ	1 tube contains: 50 pcs. 1 batch contains: 500 pcs.	1,000 pcs.

*Indicate the peak AC and DC values.

Note: The surface mount terminal shape indicator "A" and the packing style indicator "X" or "Z" are not marked on the relay.

RATING

1. Absolute maximum ratings (Ambient temperature: 25°C 77°F)

Item		Symbol	AQW414EH(A)	Remarks
Input	LED forward current	I_F	50mA	
	LED reverse voltage	V_R	5V	
	Peak forward current	I_{FP}	1A	f = 100 Hz, Duty factor = 0.1%
	Power dissipation	P_{in}	75mW	
Output	Load voltage (peak AC)	V_L	400 V	
	Continuous load current	I_L	0.1 A (0.13 A)	Peak AC, DC (): in case of using only 1 channel.
	Peak load current	I_{peak}	0.3 A	100 ms (1 shot), $V_L = DC$
	Power dissipation	P_{out}	800mW	
Total power dissipation		P_T	850mW	
I/O isolation voltage		V_{iso}	5,000 V AC	
Temperature limits	Operating	T_{opr}	-40°C to +85°C -40°F to +185°F	Non-condensing at low temperatures
	Storage	T_{stg}	-40°C to +100°C -40°F to +212°F	

GU-E 2 Form B (AQW414EH)

2. Electrical characteristics (Ambient temperature: 25°C 77°F)

Item		Symbol	AQW414EH(A)	Condition	
Input	LED operate (OFF) current	Typical	1.3mA	$I_L = \text{Max.}$	
		Maximum	3.0mA		
	LED reverse (ON) current	Minimum	0.4mA	$I_L = \text{Max.}$	
		Typical	1.2mA		
LED dropout voltage	Typical	V_F	1.25 (1.14 V at $I_F = 5\text{mA}$)	$I_F = 50\text{mA}$	
	Maximum		1.5V		
Output	On resistance	Typical	26Ω	$I_F = 0\text{mA}$ $I_L = \text{Max.}$ Within 1 s on time	
		Maximum	35Ω		
	Off state leakage current	Maximum	I_{Leak}		10μA $I_F = 5\text{mA}$ $V_L = \text{Max.}$
Transfer characteristics	Operate (OFF) time*	Typical	0.8ms	$I_F = 0\text{mA} \rightarrow 5\text{mA}$ $I_L = \text{Max.}$	
		Maximum	3.0ms		
	Reverse (ON) time*	Typical	0.2ms	$I_F = 5\text{mA} \rightarrow 0\text{mA}$ $I_L = \text{Max.}$	
		Maximum	1.0ms		
	I/O capacitance	Typical	C_{iso}	0.8pF	$f = 1\text{MHz}$ $V_B = 0\text{V}$
		Maximum		1.5pF	
Initial I/O isolation resistance	Minimum	R_{iso}	1,000MΩ	500V DC	

*Operate/Reverse time

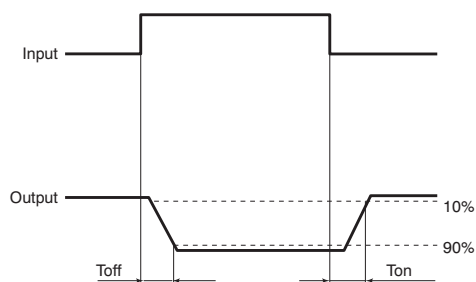

RECOMMENDED OPERATING CONDITIONS

Please obey the following conditions to ensure proper relay operation and resetting.

Item	Symbol	Recommended value	Unit
Input LED current	I_F	5 to 10	mA

■ For Dimensions, see page 61.

■ For Schematic and Wiring Diagrams, see page 66.

■ For Cautions for Use, see page 71.

■ These products are not designed for automotive use.

If you are considering to use these products for automotive applications, please contact your local Panasonic technical representative.

For more information, see page 80.

REFERENCE DATA

1. Load current vs. ambient temperature characteristics

Allowable ambient temperature: -40°C to +85°C
-40°F to +185°F

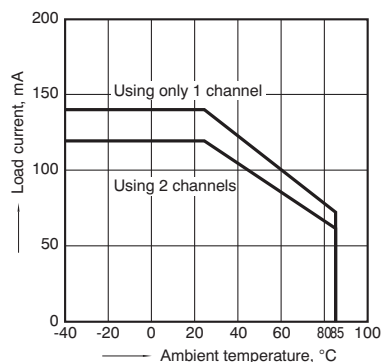

2. On resistance vs. ambient temperature characteristics

Measured portion: between terminals 5 and 6, 7 and 8;
LED current: 0 mA; Load voltage: Max. (DC);
Continuous load current: Max. (DC)

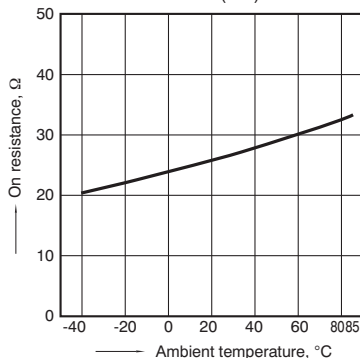

3. Operate (OFF) time vs. ambient temperature characteristics

LED current: 5 mA; Load voltage: Max. (DC);
Continuous load current: Max. (DC)

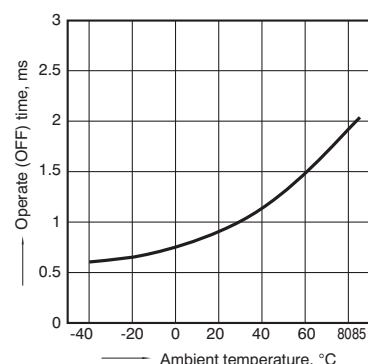

GU-E 2 Form B (AQW414EH)

4. Reverse (ON) time vs. ambient temperature characteristics

LED current: 5 mA; Load voltage: Max. (DC);
Continuous load current: Max. (DC)

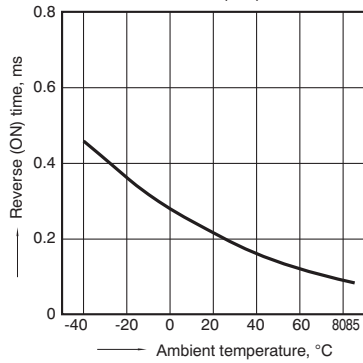

5. LED operate current vs. ambient temperature characteristics

Load voltage: Max. (DC);
Continuous load current: Max. (DC)

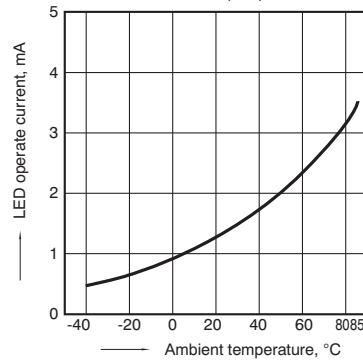

6. LED turn off current vs. ambient temperature characteristics

Load voltage: Max. (DC);
Continuous load current: Max. (DC)

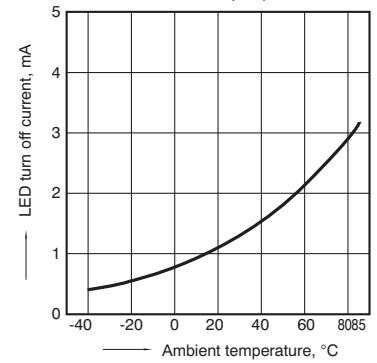

7. LED dropout voltage vs. ambient temperature characteristics;

LED current: 5 to 50 mA

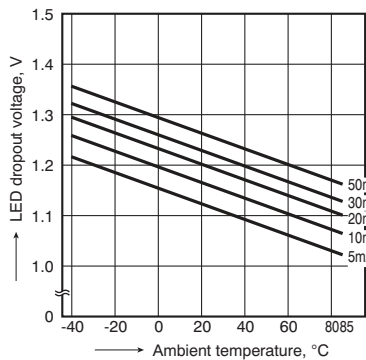

8. Current vs. voltage characteristics of output at MOS portion

Measured portion: between terminals 5 and 6, 7 and 8;
Ambient temperature: 25°C 77°F

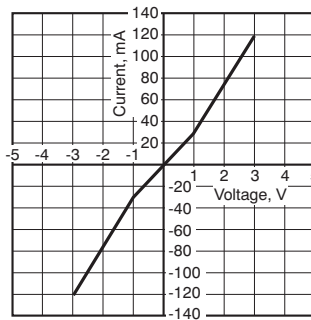

9. Off state leakage current vs. load voltage characteristics

Measured portion: between terminals 5 and 6, 7 and 8;
Ambient temperature: 25°C 77°F

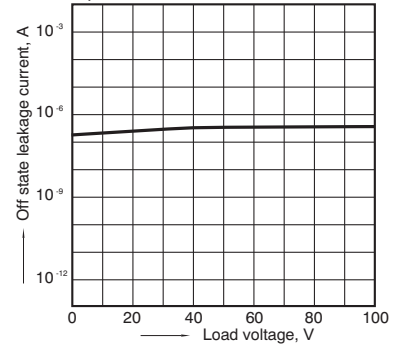

10. Operate (OFF) time vs. LED forward current characteristics

Measured portion: between terminals 5 and 6, 7 and 8;
Load voltage: Max. (DC); Continuous load current:
Max. (DC); Ambient temperature: 25°C 77°F

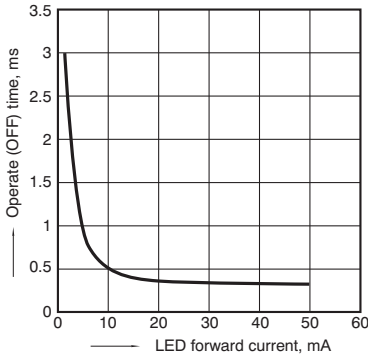

11. Reverse (ON) time vs. LED forward current characteristics

Measured portion: between terminals 5 and 6, 7 and 8;
Load voltage: Max. (DC); Continuous load current:
Max. (DC); Ambient temperature: 25°C 77°F

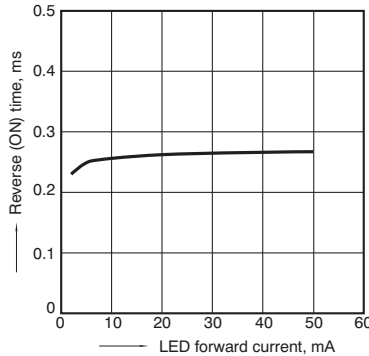

12. Output capacitance vs. applied voltage characteristics

Measured portion: between terminals 5 and 6, 7 and 8;
Frequency: 1 MHz; Ambient temperature: 25°C 77°F

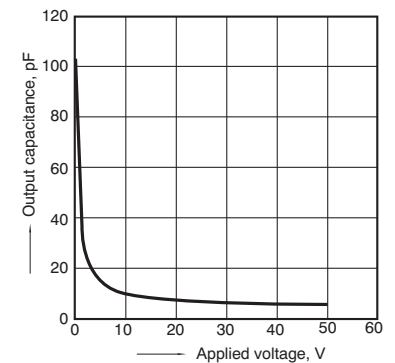

Panasonic

ideas for life



Both NO and NC contacts
incorporated in a compact
DIP8-pin
Reinforced insulation

PhotoMOS[®]
GU-E Form A & B
(AQW610EH)

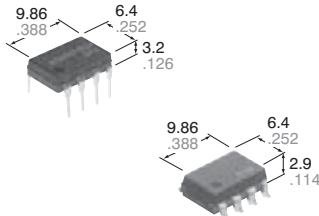

CAD Data

mm inch

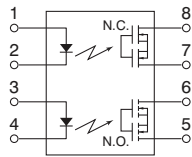

FEATURES

- 60V type couples high capacity (0.5A) with low on-resistance (typ. 1Ω).**
- Reinforced insulation 5,000 V**
More than 0.4 mm internal insulation distance between inputs and outputs. Conforms to EN41003, EN60950 (reinforced insulation).
- Approx. 1/2 the space compared with the mounting area of a set of 1 Form A and 1 Form B PhotoMOS relays**
- Applicable for 1 Form A 1 Form B use as well as two independent 1 Form A and 1 Form B use**
- Controls low-level analog signals**
PhotoMOS relays feature extremely low closed-circuit offset voltage to enable control of low-level analog signals without distortion.

6. High sensitivity and high speed response

Can control max. 0.14 A load current with 5 mA input current. Fast operation speed of typ. 0.5 ms [N.O.] (AQW610EH).

7. Low-level off-state leakage current

TYPICAL APPLICATIONS

- Power supply
- Measuring instruments
- Security equipment
- Modem
- Telephone equipment
- Electricity, plant equipment
- Sensing equipment

TYPES

	I/O isolation voltage	Output rating*		Package	Part No.				Packing quantity	
					Through hole terminal	Surface-mount terminal			Tube	Tape and reel
						Tape and reel packing style				
						Tube packing style		Picked from the 1/2/3/4-pin side		
AC/DC dual use	Reinforced 5,000 V	60 V	500 mA	DIP8-pin	AQW612EH	AQW612EHA	AQW612EHAX	AQW612EHAZ	1 tube contains: 50 pcs. 1 batch contains: 500 pcs.	1,000 pcs.
		350 V	120 mA		AQW610EH	AQW610EHA	AQW610EHAX	AQW610EHAZ		
		400 V	100 mA		AQW614EH	AQW614EHA	AQW614EHAX	AQW614EHAZ		

*Indicate the peak AC and DC values.

Note: The surface mount terminal shape indicator "A" and the packing style indicator "X" or "Z" are not marked on the relay.

RATING

1. Absolute maximum ratings (Ambient temperature: 25°C 77°F)

Item		Symbol	AQW612EH(A)	AQW610EH(A)	AQW614EH(A)	Remarks
Input	LED forward current	I_F	50 mA			
	LED reverse voltage	V_R	5 V			
	Peak forward current	I_{FP}	1 A			$f = 100 \text{ Hz}$, Duty factor = 0.1%
	Power dissipation	P_{in}	75 mW			
Output	Load voltage (peak AC)	V_L	60 V	350 V	400 V	
	Continuous load current	I_L	0.5 A (0.6 A)	0.12 A (0.14 A)	0.1 A (0.13 A)	Peak AC, DC (): in case of using only 1a or 1b, 1 channel
	Peak load current	I_{peak}	1.5 A	0.36 A	0.3 A	100 ms (1 shot), $V_L = \text{DC}$
	Power dissipation	P_{out}	800 mW			
Total power dissipation		P_T	850 mW			
I/O isolation voltage		V_{iso}	5,000 V AC			
Temperature limits	Operating	T_{opr}	-40°C to +85°C -40°F to +185°F			Non-condensing at low temperatures
	Storage	T_{stg}	-40°C to +100°C -40°F to +212°F			

GU-E Form A & B (AQW61○EH)

2. Electrical characteristics (Ambient temperature: 25°C 77°F)

Item			Symbol	AQW612EH(A)	AQW610EH(A)	AQW614EH(A)	Condition
Input	LED operate current	Typical	$I_{Fon}(N.O.)$	1.3 mA			$I_L = \text{Max.}$
		Maximum	$I_{Foff}(N.C.)$	3.0 mA			
	LED reverse current	Minimum	$I_{Foff}(N.O.)$	0.4 mA			$I_L = \text{Max.}$
		Typical	$I_{Fon}(N.C.)$	1.3 mA			
LED dropout voltage	Typical	V_F	1.25 (1.14 V at $I_F = 5 \text{ mA}$)			$I_F = 50 \text{ mA}$	
	Maximum		1.5 V				
Output	On resistance	Typical	R_{on}	1Ω	18Ω	26Ω	$I_F = 5 \text{ mA (N.O.)}$ $I_F = 0 \text{ mA (N.C.)}$ $I_L = \text{Max.}$ Within 1 s on time
		Maximum		2.5Ω	25Ω	35Ω	
	Off state leakage current	Maximum	I_{Leak}	1μA (N.O.), 10μA (N.C.)			$I_F = 0 \text{ mA (N.O.)}$ $I_F = 5 \text{ mA (N.C.)}$ $V_L = \text{Max.}$
Transfer characteristics	Operate time*	Typical	$T_{on}(N.O.)$	1.0 ms (N.O.) 3.0 ms (N.C.)	0.5 ms (N.O.) 1.0 ms (N.C.)	0.5 ms (N.O.) 0.8 ms (N.C.)	$I_F = 0 \text{ mA} \rightarrow 5 \text{ mA}$ $I_L = \text{Max.}$
		Maximum	$T_{off}(N.C.)$	4.0 ms (N.O.) 10.0 ms (N.C.)			
	Reverse time*	Typical	$T_{off}(N.O.)$	0.05ms (N.O.), 0.2ms (N.C.)	0.08ms (N.O.), 0.3ms (N.C.)	0.08ms (N.O.), 0.2ms (N.C.)	$I_F = 5 \text{ mA} \rightarrow 0 \text{ mA}$ $I_L = \text{Max.}$
		Maximum	$T_{on}(N.C.)$	1.0ms			
	I/O capacitance	Typical	C_{iso}	0.8 pF			$f = 1 \text{ MHz}$ $V_B = 0 \text{ V}$
		Maximum		1.5 pF			
Initial I/O isolation resistance	Minimum	R_{iso}	1,000MΩ			500 V DC	

*Operate/Reverse time

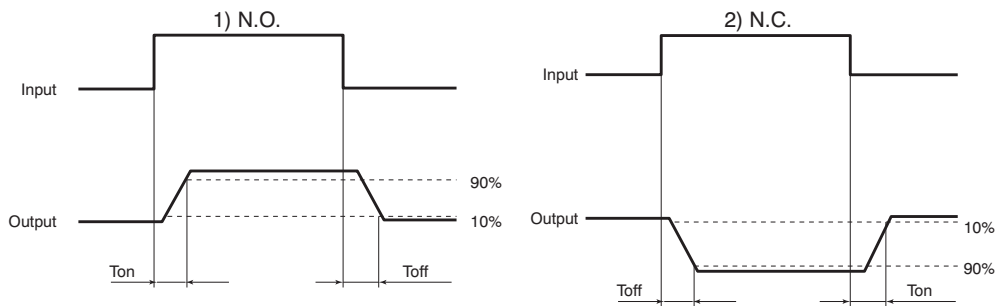

RECOMMENDED OPERATING CONDITIONS

Please obey the following conditions to ensure proper relay operation and resetting.

Item	Symbol	Recommended value	Unit
Input LED current	I_F	5 to 10	mA

■ For Dimensions, see page 61.

■ For Schematic and Wiring Diagrams, see page 66.

■ For Cautions for Use, see page 71.

■ These products are not designed for automotive use.

If you are considering to use these products for automotive applications, please contact your local Panasonic technical representative.

For more information, see page 80.

GU-E Form A & B (AQW610EH)

REFERENCE DATA

1-(1). Load current vs. ambient temperature characteristics

Allowable ambient temperature: -40°C to $+85^{\circ}\text{C}$
 -40°F to $+185^{\circ}\text{F}$

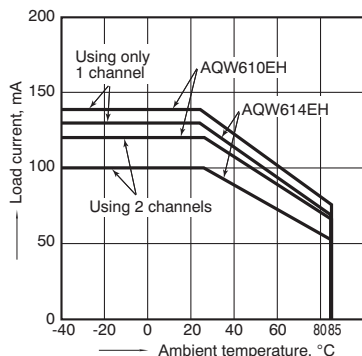

1-(2). Load current vs. ambient temperature characteristics

Allowable ambient temperature: -40°C to $+85^{\circ}\text{C}$
 -40°F to $+185^{\circ}\text{F}$

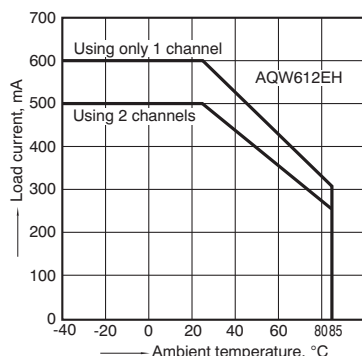

2-(1). On resistance vs. ambient temperature characteristics

Measured portion: between terminals 5 and 6, 7 and 8;
 LED current: 5 mA; Load voltage; Max. (DC)
 Continuous load current: Max. (DC)

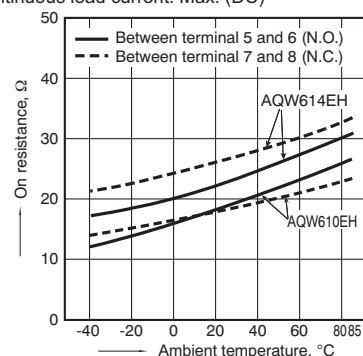

2-(2). On resistance vs. ambient temperature characteristics

Measured portion: between terminals 5 and 6, 7 and 8;
 LED current: 5 mA; Load voltage; Max. (DC)
 Continuous load current: Max. (DC)

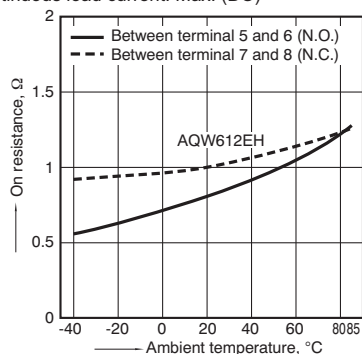

3. Operate time vs. ambient temperature characteristics

LED current: 5 mA; Load voltage: Max. (DC);
 Continuous load current: Max. (DC)

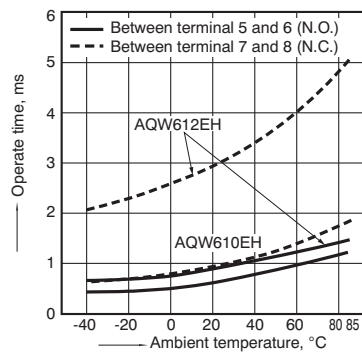

4. Reverse time vs. ambient temperature characteristics

LED current: 5 mA; Load voltage: Max. (DC);
 Continuous load current: Max. (DC)

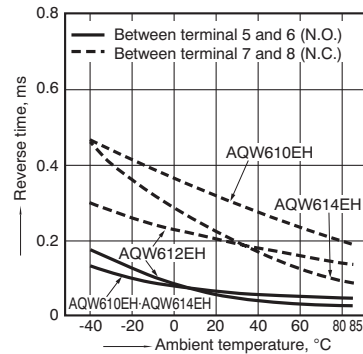

5. LED operate current vs. ambient temperature characteristics

Sample: All types;
 Load voltage: Max. (DC);
 Continuous load current: Max. (DC)

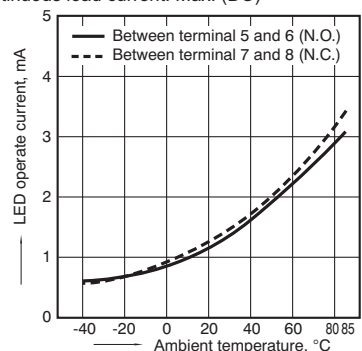

6. LED reverse current vs. ambient temperature characteristics

Sample: All types;
 Load voltage: Max. (DC);
 Continuous load current: Max. (DC)

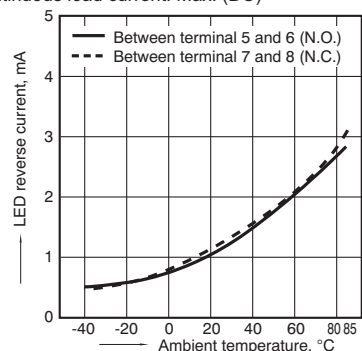

7. LED dropout voltage vs. ambient temperature characteristics

Sample: All types;
 LED current: 5 to 50 mA

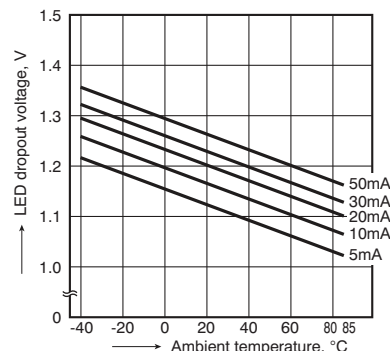

GU-E Form A & B (AQW610EH)

8-(1). Current vs. voltage characteristics of output at MOS portion

Measured portion: between terminals 5 and 6, 7 and 8;
Ambient temperature: 25°C 77°F

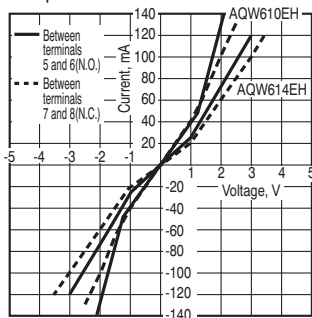

8-(2). Current vs. voltage characteristics of output at MOS portion

Measured portion: between terminals 5 and 6, 7 and 8;
Ambient temperature: 25°C 77°F

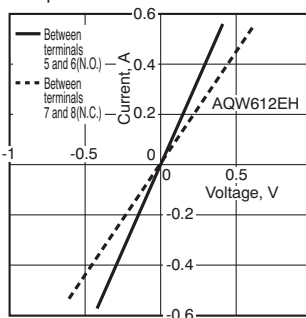

9-(1). Off state leakage current vs. load voltage characteristics

Measured portion: between terminals 5 and 6, 7 and 8;
Ambient temperature: 25°C 77°F

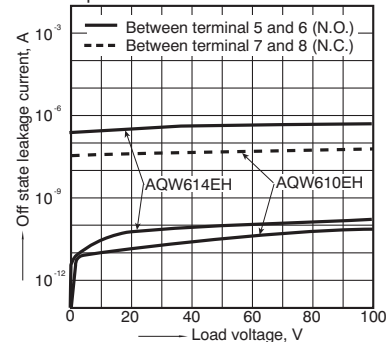

9-(2). Off state leakage current vs. load voltage characteristics

Measured portion: between terminals 5 and 6, 7 and 8;
Ambient temperature: 25°C 77°F

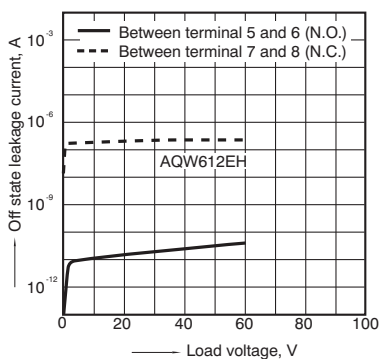

10-(1). Operate time vs. LED forward current characteristics

Measured portion: between terminals 5 and 6, 7 and 8;
Load voltage: Max. (DC); Continuous load current: Max. (DC); Ambient temperature: 25°C 77°F

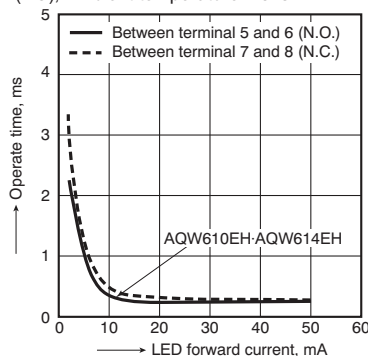

10-(2). Operate time vs. LED forward current characteristics

Measured portion: between terminals 5 and 6, 7 and 8;
Load voltage: Max. (DC); Continuous load current: Max. (DC); Ambient temperature: 25°C 77°F

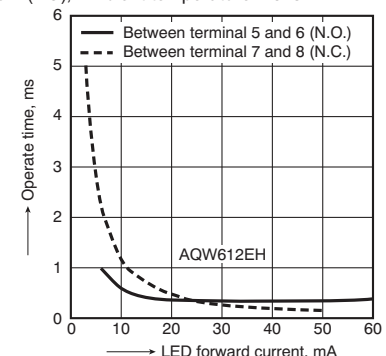

11-(1). Reverse time vs. LED forward current characteristics

Measured portion: between terminals 5 and 6, 7 and 8;
Load voltage: Max. (DC); Continuous load current: Max. (DC); Ambient temperature: 25°C 77°F

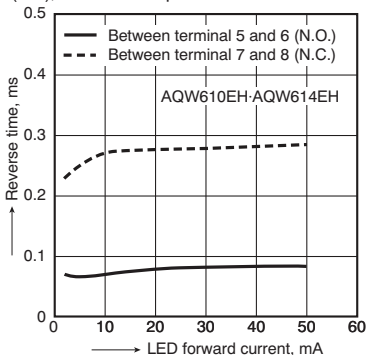

11-(2). Reverse time vs. LED forward current characteristics

Measured portion: between terminals 5 and 6, 7 and 8;
Load voltage: Max. (DC); Continuous load current: Max. (DC); Ambient temperature: 25°C 77°F

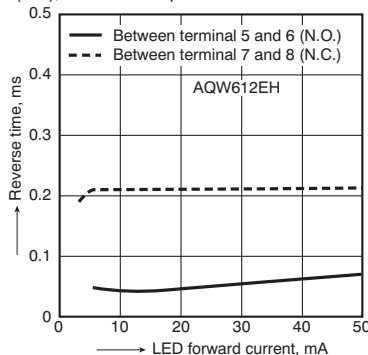

12-(1). Output capacitance vs. applied voltage characteristics

Measured portion: between terminals 5 and 6, 7 and 8;
Frequency: 1 MHz;
Ambient temperature: 25°C 77°F

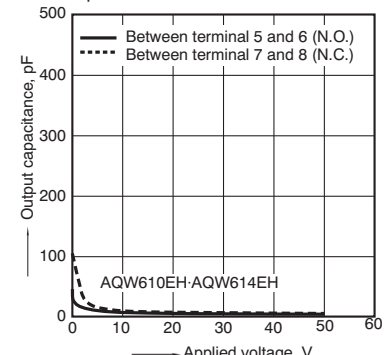

12-(2). Output capacitance vs. applied voltage characteristics

Measured portion: between terminals 5 and 6, 7 and 8;
Frequency: 1 MHz;
Ambient temperature: 25°C 77°F

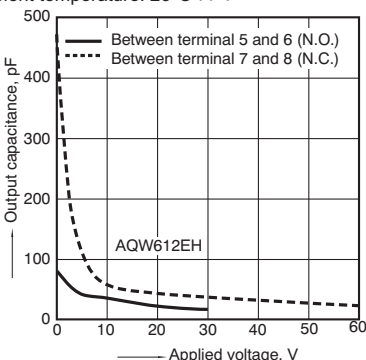

Panasonic

ideas for life



DIP6-pin type suited for
radio frequent switching

PhotoMOS[®]
RF 1 Form A
(AQV220)

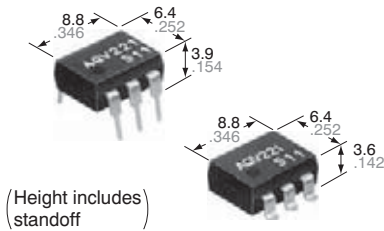

CAD Data

mm inch

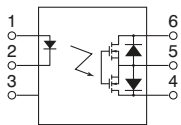

FEATURES

1. High frequency characteristics with low capacitance between output terminals

Low output capacitance: typ. 4.8 pF
Isolation loss: 40 dB or more (at 1 MHz)
(AQV225)

2. High speed switching

Turn on time: typ. 0.1 ms
Turn off time: typ. 0.03 ms

3. Low-level off state leakage current of typ. 0.03 nA

4. Controls low-level analog signals

PhotoMOS relay features extremely low closed-circuit offset voltages to enable control of small analog signals without distortion.

TYPICAL APPLICATIONS

1. Measuring instruments

Scanner, IC checker, Board tester, etc.

2. Audio visual equipment

CD, VCR

3. Security equipment

TYPES

	Output rating*		Package	Part No.				Packing quantity	
	Load voltage	Load current		Through hole terminal	Surface-mount terminal		Tube	Tape and reel	
					Tape and reel packing style				
AC/DC dual use	40 V	80 mA	DIP6-pin	Tube packing style	Picked from the 1/2/3-pin side	Picked from the 4/5/6-pin side	1 tube contains: 50 pcs. 1 batch contains: 500 pcs.	1,000 pcs	
	80 V	50 mA		AQV221	AQV221A	AQV221AX	AQV221AZ		
				AQV225	AQV225A	AQV225AX	AQV225AZ		

*Indicate the peak AC and DC values.

Note: The surface mount terminal shape indicator "A" and the packing style indicator "X" or "Z" are not marked on the relay.

RATING

1. Absolute maximum ratings (Ambient temperature: 25°C 77°F)

Item		Symbol	Type of connection	AQV221(A)	AQV225(A)	Remarks
Input	LED forward current	I_F		50 mA		
	LED reverse voltage	V_R		5 V		
	Peak forward current	I_{FP}		1 A		$f = 100$ Hz, Duty factor = 0.1%
	Power dissipation	P_{in}		75 mW		
Output	Load voltage (peak AC)	V_L		40 V	80 V	
	Continuous load current	I_L	A	0.08 A	0.05 A	A connection: Peak AC, DC B, C connection: DC
			B	0.09 A	0.06 A	
			C	0.12 A	0.075 A	
	Peak load current	I_{peak}		0.18 A	0.15 A	A connection: 100 ms (1 shot), $V_L = DC$
Power dissipation	P_{out}		230 mW			
Total power dissipation		P_T		280 mW		
I/O isolation voltage		V_{iso}		1,500 V AC		
Temperature limits	Operating	T_{opr}		-40°C to +85°C -40°F to +185°F		Non-condensing at low temperatures
	Storage	T_{stg}		-40°C to +100°C -40°F to +212°F		

RF 1 Form A (AQV22○)

2. Electrical characteristics (Ambient temperature: 25°C 77°F)

Item		Symbol	Type of connection	AQV221(A)	AQV225(A)	Remarks		
Input	LED operate current	Typical	I _{Fon}	0.9 mA		I _L = Max.		
		Maximum		3 mA				
	LED turn off current	Minimum	I _{Foff}	0.4 mA		I _L = Max.		
		Typical		0.85 mA				
	LED dropout voltage	Typical	V _F	1.25 V (1.14 V at I _F = 5 mA)		I _F = 50 mA		
		Maximum		1.5 V				
Output	On resistance	Typical	R _{on}	A	22 Ω	36 Ω	I _F = 5 mA I _L = Max. Within 1 s on time	
		Maximum			35 Ω	50 Ω		
		Typical	R _{on}	B	13 Ω	21 Ω		
		Maximum			18 Ω	25 Ω		
	Output capacitance	Typical	C _{out}	—	5.6 pF	4.8 pF	I _F = 0 mA V _B = 0 V f = 1 MHz	
		Maximum			8 pF			
	Off state leakage current	Typical	I _{Leak}	—	0.03 nA		I _F = 0 mA V _L = Max.	
		Maximum			10 nA			
	Transfer characteristics	Turn on time*	Typical	T _{on}	—	0.1 ms		I _F = 5 mA I _L = Max.
			Maximum			0.3 ms		
Turn off time*		Typical	T _{off}	—	0.03 ms		I _F = 5 mA I _L = Max.	
		Maximum			0.1 ms			
I/O capacitance		Typical	C _{iso}	—	0.8 pF		f = 1 MHz V _B = 0 V	
		Maximum			1.5 pF			
Initial I/O isolation resistance	Minimum	R _{iso}	—	1,000 MΩ		500 V DC		

*Turn on/Turn off time

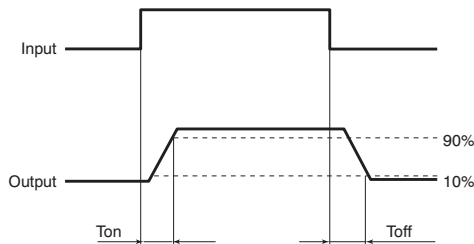

RECOMMENDED OPERATING CONDITIONS

Please obey the following conditions to ensure proper relay operation and resetting.

Item	Symbol	Recommended value	Unit
Input LED current	I _F	5	mA

■ For Dimensions, see page 60.

■ For Schematic and Wiring Diagrams, see page 65.

■ For Cautions for Use, see page 71.

■ These products are not designed for automotive use.

If you are considering to use these products for automotive applications, please contact your local Panasonic technical representative.

For more information, see page 80.

RF 1 Form A (AQV22○)

REFERENCE DATA

1. Load current vs. ambient temperature characteristics

Allowable ambient temperature: -40°C to $+85^{\circ}\text{C}$
 -40°F to $+185^{\circ}\text{F}$

Type of connection: A

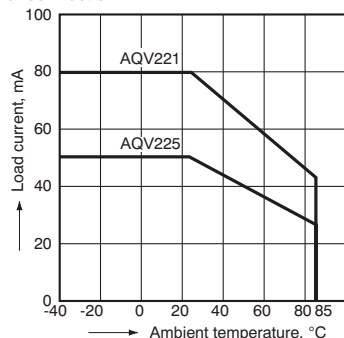

2. On resistance vs. ambient temperature characteristics

Measured portion: between terminals 4 and 6;
 LED current: 5 mA; Load voltage: Max. (DC);
 Continuous load current: Max. (DC)

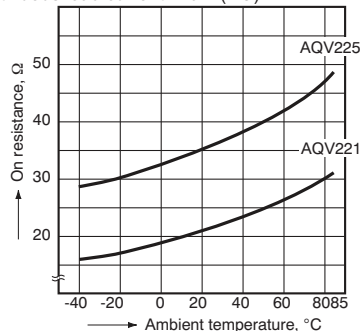

3. Turn on time vs. ambient temperature characteristics

Sample: AQV221, AQV225; LED current: 5 mA;
 Load voltage: Max. (DC);
 Continuous load current: Max. (DC)

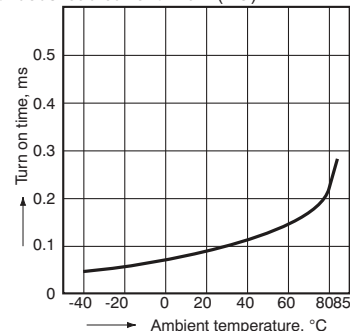

4. Turn off time vs. ambient temperature characteristics

Sample: AQV221, AQV225; LED current: 5 mA;
 Load voltage: Max. (DC);
 Continuous load current: Max. (DC)

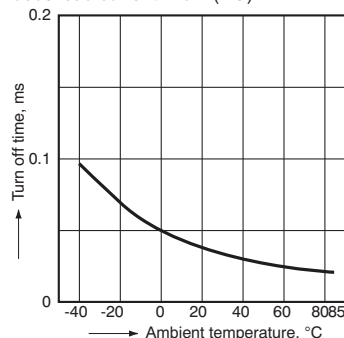

5. LED operate current vs. ambient temperature characteristics

Sample: AQV221, AQV225;
 Load voltage: Max. (DC);
 Continuous load current: Max. (DC)

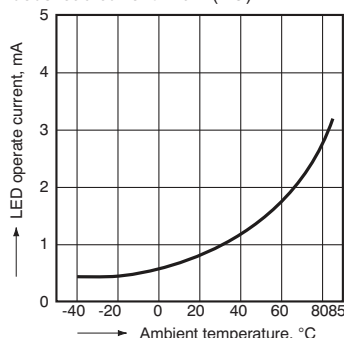

6. LED turn off current vs. ambient temperature characteristics

Sample: AQV221, AQV225;
 Load voltage: Max. (DC);
 Continuous load current: Max. (DC)

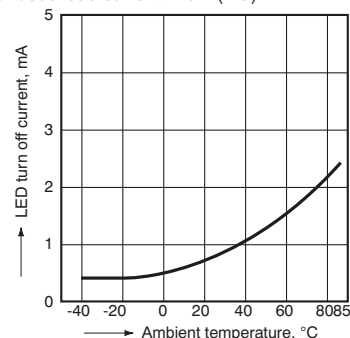

7. LED dropout voltage vs. ambient temperature characteristics

Sample: AQV221, AQV225;
 LED current: 5 to 50 mA

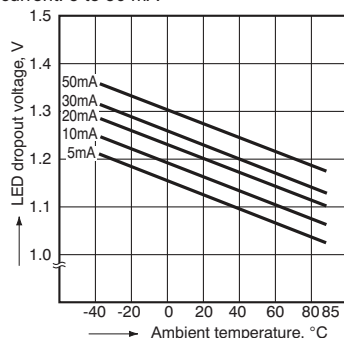

8. Current vs. voltage characteristics of output at MOS portion

Measured portion: between terminals 4 and 6;
 Ambient temperature: 25°C 77°F

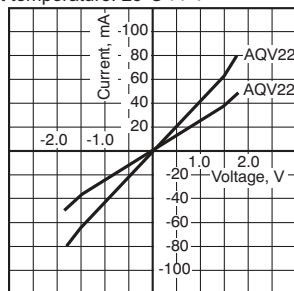

9. Off state leakage current vs. load voltage characteristics

Measured portion: between terminals 4 and 6;
 Ambient temperature: 25°C 77°F

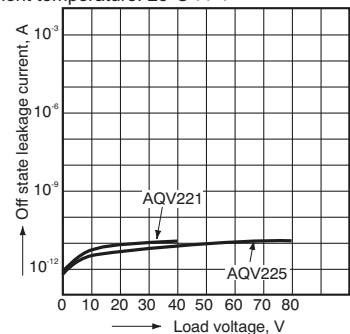

RF 1 Form A (AQV22○)

10. Turn on time vs. LED forward current characteristics

Sample: AQV221, AQV225;

Measured portion: between terminals 4 and 6;

Load voltage: Max. (DC);

Continuous load current: Max. (DC);

Ambient temperature: 25°C 77°F

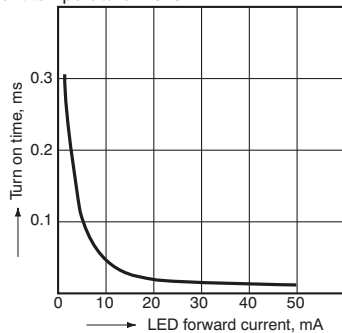

11. Turn off time vs. LED forward current characteristics

Sample: AQV221, AQV225;

Measured portion: between terminals 4 and 6;

Load voltage: Max. (DC);

Continuous load current: Max. (DC);

Ambient temperature: 25°C 77°F

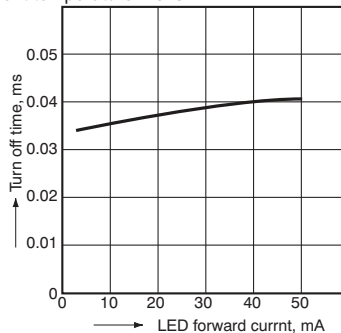

12. Output capacitance vs. applied voltage characteristics

Measured portion: between terminals 4 and 6;

Frequency: 1 MHz;

Ambient temperature: 25°C 77°F

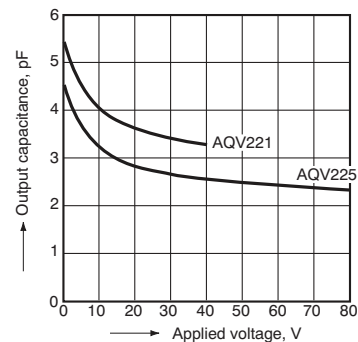

13. Isolation vs. frequency characteristics (50Ω impedance)

Measured portion: between terminals 4 and 6;

Frequency: 1 MHz;

Ambient temperature: 25°C 77°F

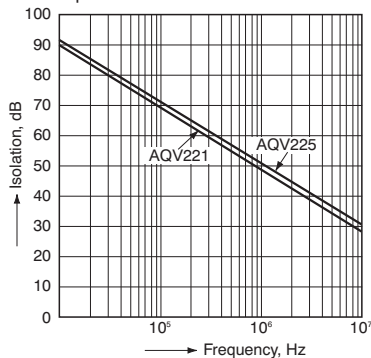

14. Insertion loss vs. frequency characteristics (50Ω impedance)

Measured portion: between terminals 4 and 6;

Frequency: 1 MHz;

Ambient temperature: 25°C 77°F

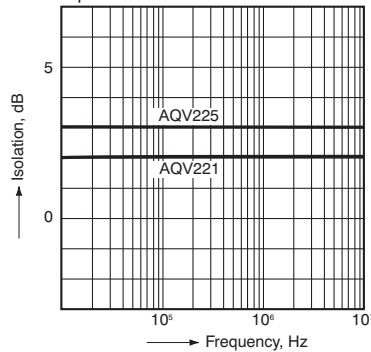

Panasonic

ideas for life

4.6 mm² mounting area
C×R10: 40 V load voltage
C×R5: 25 V load voltage

PhotoMOS[®]
RF VSSOP 1 Form A C×R10/C×R5
(AQY2)

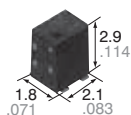

CAD Data

mm inch

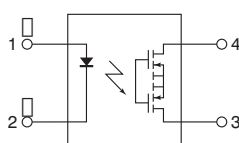

FEATURES

1. VSSOP type with further reduction in mounting area

4.6 mm² mounting area achieved. Approx 29% less than previous product (SON type).

Contributes to the miniaturization of instruments and higher density mounting.

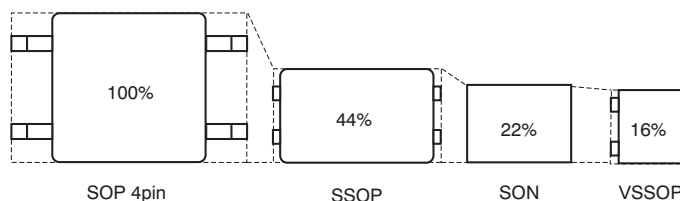

2. Low on resistance and low output capacitance available

• C×R10

<R type> Output capacitance: 14 pF (typical)

On resistance: 0.8Ω (typical)

<C type> Output capacitance: 1.1 pF (typical)

On resistance: 9.5Ω (typical)

• C×R5

Output capacitance: 1.1 pF (typical)

On resistance: 5.5Ω (typical)

TYPICAL APPLICATIONS

1. Measuring and testing equipment

IC tester, Probe card, Board tester and other testing equipment

2. Telecommunication equipment

TYPES

Type			Output rating*1		Part No. (Tape and reel packing style)*2		Packing quantity in the tape and reel
			Load voltage	Load current	Picked from the 1 and 4-pin side	Picked from the 2 and 3-pin side	
AC/DC type	C×R10	Low on resistance (R type)	40 V	250 mA	AQY221R2TY	AQY221R2TW	1,000 pcs.
		Low output capacitance (C type)	40 V	120 mA	AQY221N2TY	AQY221N2TW	
	C×R5	25 V	150 mA	AQY221N3TY	AQY221N3TW		

Notes: *1 Indicate the peak AC and DC values.

*2 Only tape and reel package is available.

For space reasons, only "1R2", "1N2" or "1N3" is marked on the product as the part number.

RATING

1. Absolute maximum ratings (Ambient temperature: 25°C 77°F)

Item	Symbol	C×R10 R type	C×R10 C type	C×R5 type	Remarks
		AQY221R2T	AQY221N2T	AQY221N3T	
Input side	LED forward current	50 mA			
	LED reverse voltage	5 V			
	Peak forward current	1 A			f = 100 Hz, Duty factor = 0.1%
	Power dissipation	75 mW			
Output side	Load voltage (peak AC)	40 V	40 V	25 V	
	Continuous load current	0.25 A	0.12 A	0.15 A	Peak AC, DC
	Peak load current	0.75 A	–	–	100 ms (1shot), V _L = DC
	Power dissipation	250 mW			
Total power dissipation	P _T	300 mW			
I/O isolation voltage	V _{iso}	200 V AC			
Operating temperature	T _{opr}	–40°C to +85°C –40°F to +185°F			Non-condensing at low temperatures
Storage temperature	T _{stg}	–40°C to +100°C –40°F to +212°F			

RF VSSOP 1 Form A C×R10/C×R5 (AQY2)

2. Electrical characteristics (Ambient temperature: 25°C 77°F)

Item		Symbol	C×R10 R type	C×R10 C type	C×R5 type	Condition	
			AQY221R2T	AQY221N2T	AQY221N3T		
Input	LED operate current	Typical	0.5 mA	0.7 mA		AQY221R2T: I _L = 250 mA AQY221N2T: I _L = 80 mA AQY221N3T: I _L = 80 mA	
		Maximum	3 mA				
	LED turn off current	Minimum	0.1 mA	0.2 mA			
Typical		0.4 mA	0.6 mA				
LED dropout voltage	Typical	V _F	1.14 V			I _F = 5 mA	
	Maximum		1.5 V				
Output	On resistance	Typical	0.8 Ω	9.5 Ω	5.5 Ω	AQY221R2T: I _F = 5 mA, I _L = 250 mA AQY221N2T: I _F = 5 mA, I _L = 80 mA AQY221N3T: I _F = 5 mA, I _L = 80 mA Within 1 s on time	
		Maximum	1.25 Ω	12.5 Ω	7.5 Ω		
	Output capacitance	Typical	14 pF	1.1 pF			
		Maximum	18 pF	1.5 pF			
Off state leakage current	Typical	I _{Leak}	0.02 nA	0.01 nA		I _F = 0 mA, V _L = Max.	
	Maximum		10 nA				
Transfer characteristics	Turn on time*	Typical	0.1 ms	0.01 ms		AQY221R2T: I _F = 5 mA, V _L = 10 V, R _L = 40 Ω AQY221N2T: I _F = 5 mA, V _L = 10 V, R _L = 125 Ω AQY221N3T: I _F = 5 mA, V _L = 10 V, R _L = 125 Ω	
		Maximum	0.5 ms	0.2 ms			
	Turn off time*	Typical	0.06 ms	0.03 ms			
		Maximum	0.2 ms				
	I/O capacitance	Typical	C _{iso}	0.4 pF			
		Maximum		1.5 pF			

Note: Please refer to the "Schematic and Wiring Diagrams" for connection method.

*Turn on/Turn off time

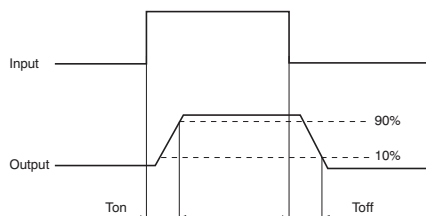

RECOMMENDED OPERATING CONDITIONS

Please obey the following conditions to ensure proper this device operation and resetting.

Item	Symbol	Recommended value	Unit
Input LED current	I _F	5	mA

For Cautions for Use, see page 71.

■ These products are not designed for automotive use.

If you are considering to use these products for automotive applications, please contact your local Panasonic technical representative.

For more information, see page 80.

REFERENCE DATA

1. Load current vs. ambient temperature characteristics

Allowable ambient temperature: -40°C to +85°C
-40°F to +185°F

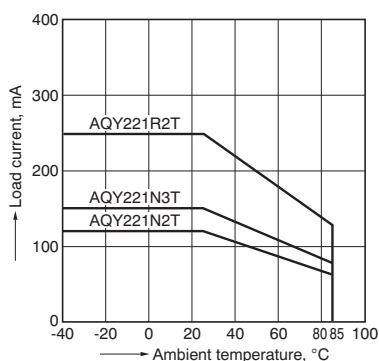

2. Load current vs. Load voltage characteristics
Ambient temperature: 25°C 77°F

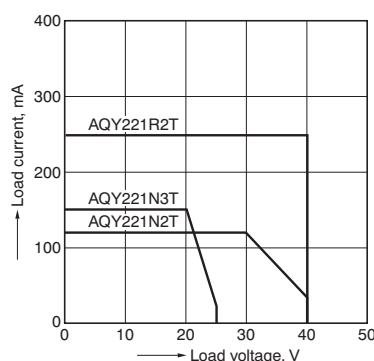

3. On resistance vs. ambient temperature characteristics

Measured portion: between terminals 3 and 4; LED current: 5 mA; Load voltage: 10V (DC); Continuous load current: 250 mA (DC) [R type], 80 mA (DC) [C type]

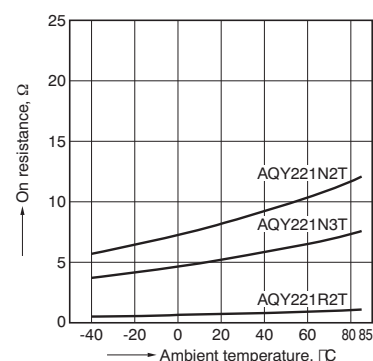

RF VSSOP 1 Form A C×R10/C×R5 (AQY2)

4. Turn on time vs. ambient temperature characteristics

Measured portion: between terminals 3 and 4; LED current: 5 mA; Load voltage: 10V (DC); Continuous load current: 250 mA (DC) [R type], 80 mA (DC) [C type]

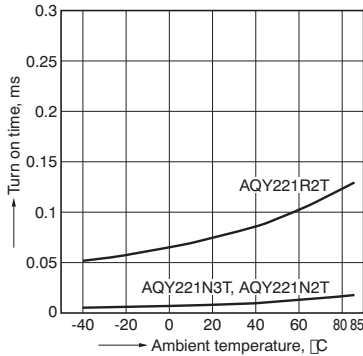

5. Turn off time vs. ambient temperature characteristics

Measured portion: between terminals 3 and 4; LED current: 5 mA; Load voltage: 10V (DC); Continuous load current: 250 mA (DC) [R type], 80 mA (DC) [C type]

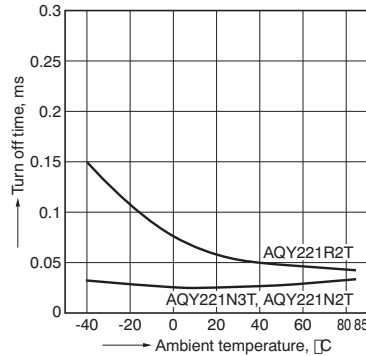

6. LED operate current vs. ambient temperature characteristics

Measured portion: between terminals 3 and 4; Load voltage: 10V (DC); Continuous load current: 250 mA (DC) [R type], 80 mA (DC) [C type]

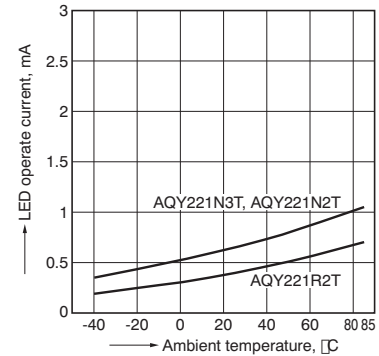

7. LED turn off current vs. ambient temperature characteristics

Measured portion: between terminals 3 and 4; Load voltage: 10V (DC); Continuous load current: 250 mA (DC) [R type], 80 mA (DC) [C type]

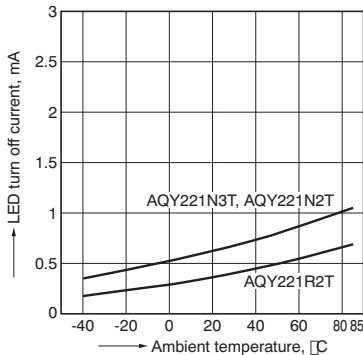

8. LED dropout voltage vs. ambient temperature characteristics

LED current: 5 to 50 mA

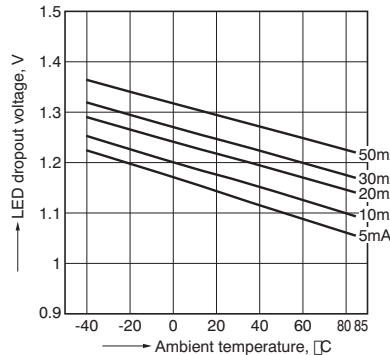

9. Current vs. voltage characteristics of output at MOS portion

Measured portion: between terminals 3 and 4; Ambient temperature: 25°C 77°F

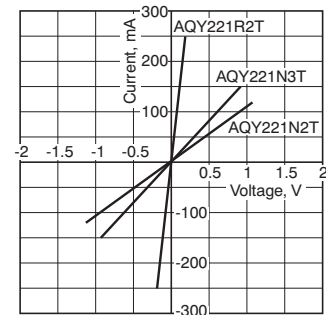

10. Off state leakage current vs. load voltage characteristics

Measured portion: between terminals 3 and 4; Ambient temperature: 25°C 77°F

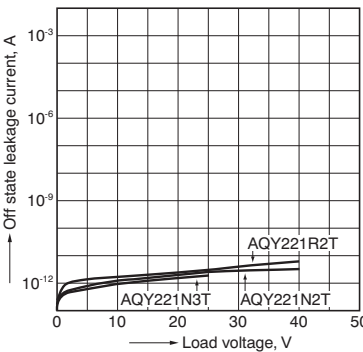

11. Turn on time vs. LED forward current characteristics

Measured portion: between terminals 3 and 4; Load voltage: 10V (DC); Continuous load current: 250 mA (DC) [R type], 80 mA (DC) [C type]; Ambient temperature: 25°C 77°F

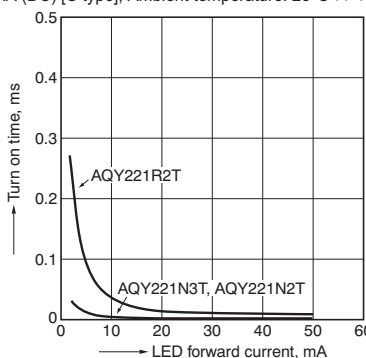

12. Turn off time vs. LED forward current characteristics

Measured portion: between terminals 3 and 4; Load voltage: 10V (DC); Continuous load current: 250 mA (DC) [R type], 80 mA (DC) [C type]; Ambient temperature: 25°C 77°F

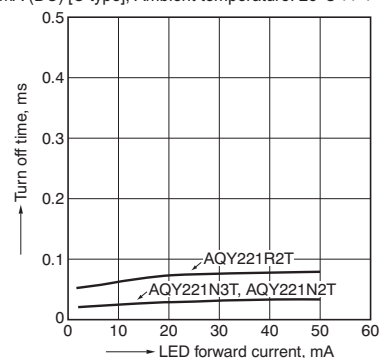

13. Output capacitance vs. applied voltage characteristics

Measured portion: between terminals 3 and 4; Frequency: 1 MHz (30m Vrms); Ambient temperature: 25°C 77°F

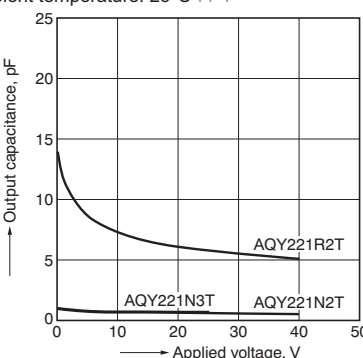

14. Isolation vs. frequency characteristics (50Ω impedance)

Measured portion: between terminals 3 and 4; Ambient temperature: 25°C 77°F

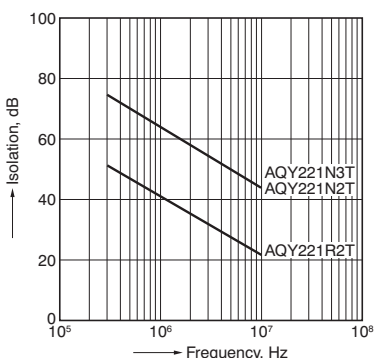

15. Insertion loss vs. frequency characteristics (50Ω impedance)

Measured portion: between terminals 3 and 4; Ambient temperature: 25°C 77°F

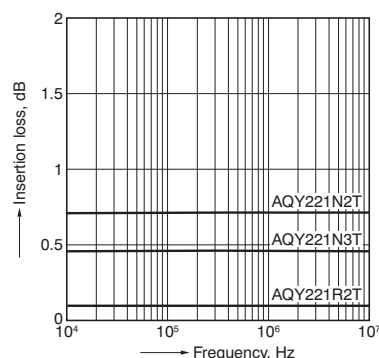

RF VSSOP 1 Form A C×R10/C×R5 (AQY2)

16.-(1) On resistance distribution

Sample: AQY221R2T

Measured portion: between terminals 3 and 4

Continuous load current: 250 mA (DC), n: 50pcs.

Ambient temperature: 25°C 77°F

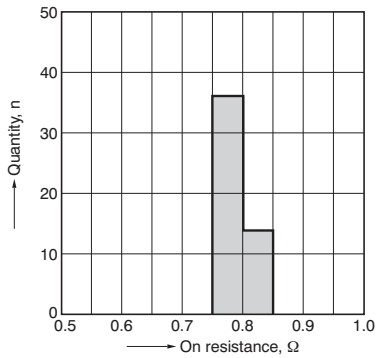

16.-(2) On resistance distribution

Sample: AQY221N2T

Measured portion: between terminals 3 and 4

Continuous load current: 80 mA (DC), n: 50pcs.

Ambient temperature: 25°C 77°F

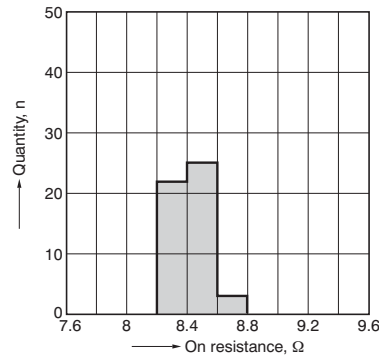

16.-(3) On resistance distribution

Sample: AQY221N3T

Measured portion: between terminals 3 and 4

Continuous load current: 80 mA (DC), n: 50pcs.

Ambient temperature: 25°C 77°F

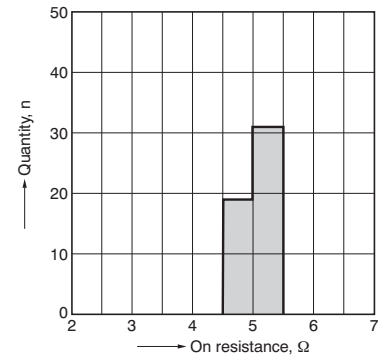

17.-(1) Turn on time distribution

Sample: AQY221R2T

Load voltage: 10V (DC)

Continuous load current: 250 mA (DC), n: 50pcs.

Ambient temperature: 25°C 77°F

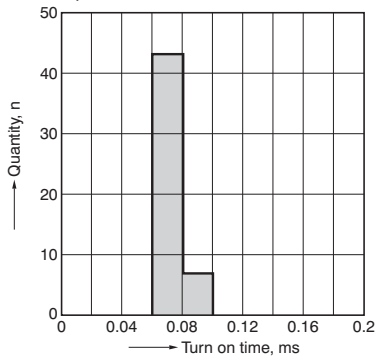

17.-(2) Turn on time distribution

Sample: AQY221N2T

Load voltage: 10V (DC)

Continuous load current: 80 mA (DC), n: 50pcs.

Ambient temperature: 25°C 77°F

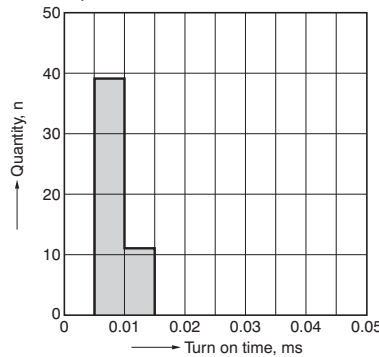

17.-(3) Turn on time distribution

Sample: AQY221N3T

Load voltage: 10V (DC)

Continuous load current: 80 mA (DC), n: 50pcs.

Ambient temperature: 25°C 77°F

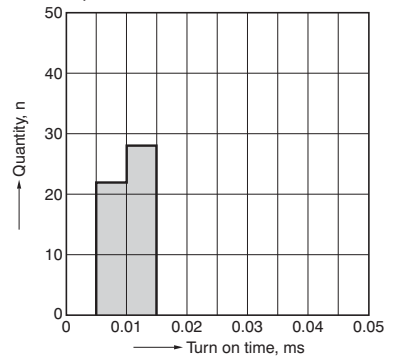

18.-(1) Turn off time distribution

Sample: AQY221R2T

Load voltage: 10V (DC)

Continuous load current: 250 mA (DC), n: 50pcs.

Ambient temperature: 25°C 77°F

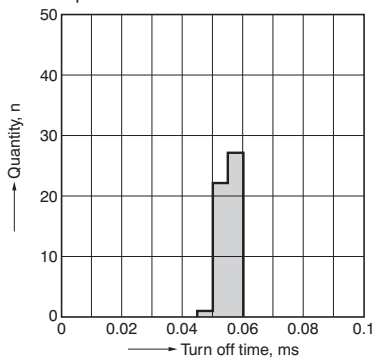

18.-(2) Turn off time distribution

Sample: AQY221N2T

Load voltage: 10V (DC)

Continuous load current: 80 mA (DC), n: 50pcs.

Ambient temperature: 25°C 77°F

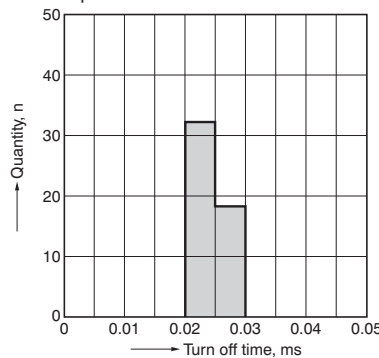

18.-(3) Turn off time distribution

Sample: AQY221N3T

Load voltage: 10V (DC)

Continuous load current: 80 mA (DC), n: 50pcs.

Ambient temperature: 25°C 77°F

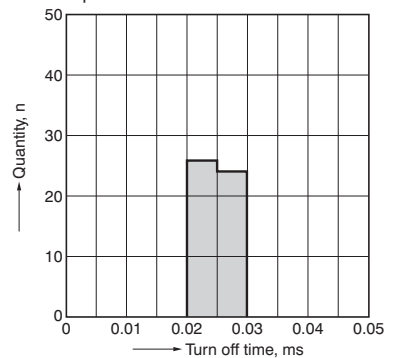

19.-(1) LED operate current distribution

Sample: AQY221R2T

Load voltage: 10V (DC)

Continuous load current: 250 mA (DC), n: 50pcs.

Ambient temperature: 25°C 77°F

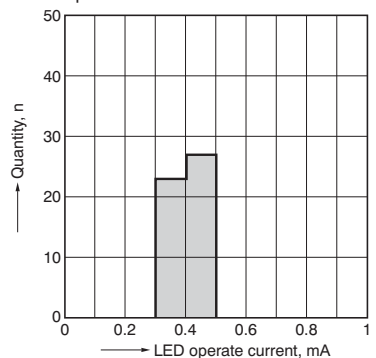

19.-(2) LED operate current distribution

Sample: AQY221N2T

Load voltage: 10V (DC)

Continuous load current: 80 mA (DC), n: 50pcs.

Ambient temperature: 25°C 77°F

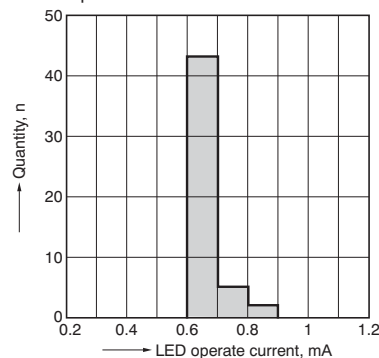

19.-(3) LED operate current distribution

Sample: AQY221N3T

Load voltage: 10V (DC)

Continuous load current: 80 mA (DC), n: 50pcs.

Ambient temperature: 25°C 77°F

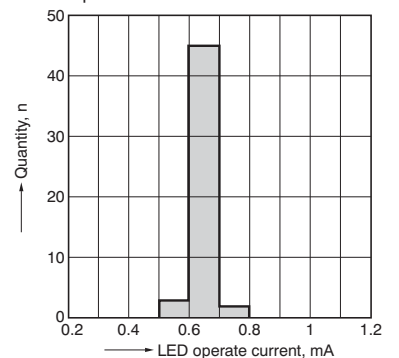

RF VSSOP 1 Form A C×R10/C×R5 (AQY2)

DIMENSIONS (mm inch)

Download [CAD Data](#) from our Web site.

CAD Data

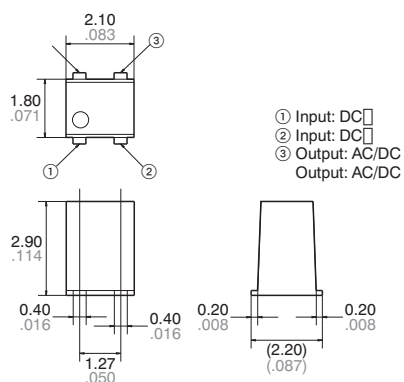

External dimensions

General tolerance: $\pm 0.1 \pm .004$

Recommended mounting pad (Top view)

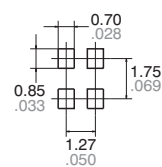
Tolerance: $\pm 0.1 \pm .004$

SCHEMATIC AND WIRING DIAGRAMS

E₁: Power source at input side, I_F: LED forward current, V_L: Load voltage, I_L: Load current

Schematic	Output configuration	Load	Connection	Wiring diagram
	1 Form A	AC/DC	—	

RF VSSOP 1 Form A C×R10/C×R5 (AQY2)

PhotoMOS CAUTIONS FOR USE

SAFETY WARNINGS

• Do not use the product under conditions that exceed the range of its specifications. It may cause overheating, smoke, or fire.

• Do not touch the recharging unit while the power is on. There is a danger of electrical shock. Be sure to turn off the power when performing mounting, maintenance, or repair operations on the device (including connecting parts such as the terminal board and socket).

• Check the connection diagrams in the catalog and be sure to connect the terminals correctly. Erroneous connections could lead to unexpected operating errors, overheating, or fire.

1. Please refer to “PhotoMOS®” catalog (latest version) for cautions for use and explanations of terminology.

2. Derated designs

Consideration of reliability is absolutely imperative for derated designs because of its importance to the working lifetime of the product.

Please be sure to derate sufficiently from the maximum rating of the device when designing a system. Be sure to conduct real-life testing of the product; and, if necessary, provide extra leeway against the maximum rating by taking sufficiently safety measures.

3. Applying stress that exceeds the absolute maximum rating

If the voltage or current value for any of the terminals exceeds the absolute maximum rating, internal elements will deteriorate because of the excessive voltage or current. In extreme cases, wiring may melt, or silicon P/N junctions may be destroyed.

Therefore, the circuit should be designed in such a way that the load never exceed the absolute maximum ratings, even momentarily.

4. Deterioration and destruction caused by discharge of static electricity

This phenomenon is generally called static electricity destruction, and occurs when static electricity generated by various factors is discharged while the device terminals are in contact, producing internal destruction of the element.

To prevent problems from static electricity, the following precautions and measures should be taken when using your device.

1) Employees handling devices should wear anti-static clothing and should be grounded through protective resistance of 500 kΩ to 1 MΩ.

2) A conductive metal sheet should be placed over the work table. Measuring instruments and jigs should be grounded.

3) When using soldering irons, either use irons with low leakage current, or ground the tip of the soldering iron. (Use of low-voltage soldering irons is also recommended.)

4) Devices and equipment used in assembly should also be grounded.

5) When packing printed circuit boards and equipment, avoid using high-polymer materials such as foam styrene, plastic, and other materials which carry an electrostatic charge.

6) When storing or transporting devices, the environment should not be conducive to generating static electricity (for instance, the humidity should be between 45 and 60%), and devices should be protected using conductive packing materials.

5. Short across terminals

Do not short circuit between terminals when device is energized, since there is possibility of breaking of the internal IC.

6. Output spike voltages

1) If an inductive load generates spike voltages which exceed the absolute maximum rating, the spike voltage must be limited. Typical circuits are shown below.

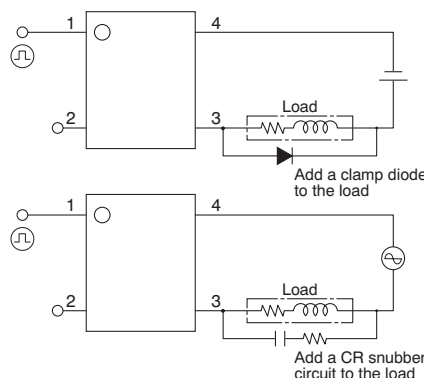

2) Even if spike voltages generated at the load are limited with a clamp diode if the circuit wires are long, spike voltages will occur by inductance. Keep wires as short as possible to minimize inductance.

7. Ripple in the input power supply

If ripple is present in the input power supply, observe the following:

1) For LED operate current at E_{min} , maintain the value mentioned in the table of “Recommended LED forward current (I_F).”

2) Keep the LED operate current at 50 mA or less at E_{max} .

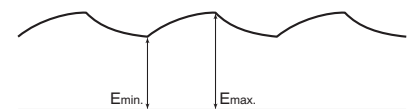

8. Soldering

• Example of recommended soldering conditions

(1) IR (Infrared reflow) soldering method

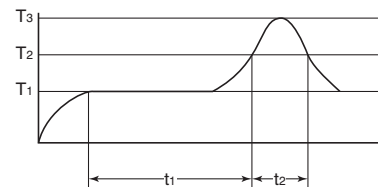

$T_1 = 150$ to 180 [°C 302 to 356] F
 $T_2 = 230$ [°C 446] F
 $T_3 = 245$ [°C 473] F or less
 $t_1 = 60$ to 120 s or less
 $t_2 = 30$ s or less

(2) Soldering iron method

Tip temperature: 350 to 400°C 662 to 752°F

Wattage: 30 to 60 W

Soldering time: within 3 s

(3) Others

Check mounting conditions before using other soldering methods (VPS, hot-air, hot plate, laser, pulse heater, etc.)

RF VSSOP 1 Form A C×R10/C×R5 (AQY2)

9. Notes for mounting

1) If many different packages are combined on a single substrate, then lead temperature rise is highly dependent on package size. For this reason, please make sure that the temperature of the terminal solder area of the PhotoMOS falls within the temperature conditions of item "8. Soldering" before mounting.

2) If the mounting conditions exceed the recommended solder conditions in item 8, resin strength will fall and the nonconformity of the heat expansion coefficient of each constituent material will increase markedly, possibly causing cracks in the package, severed bonding wires, and the like. For this reason, please inquire with us about whether this use is possible.

10. Cleaning

This product creates a light path by coupling with resin the LED of the emitting element and the solar cell of the receiving element. For this reason, ultrasonic cleaning should be avoided as much as possible, because the product differs from other molded resin products that contain discrete elements (MOS transistors and bipolar transistors, etc.). We recommend cleaning with an organic solvent. If you cannot avoid using ultrasonic cleansing, please ensure that the following conditions are met, and check beforehand for defects.

- Frequency: 27 to 29 kHz
- Ultrasonic output: No greater than 0.25W/cm²
- Cleaning time: No longer than 30 s

• Cleanser used: Asahiklin AK-225

• Other: Submerge in solvent in order to prevent the PCB and elements from being contacted directly by the ultrasonic vibrations.

Note: Applies to unit area ultrasonic output for ultrasonic baths.

11. Device packaging format

Tape and reel (Unit: mm inch)

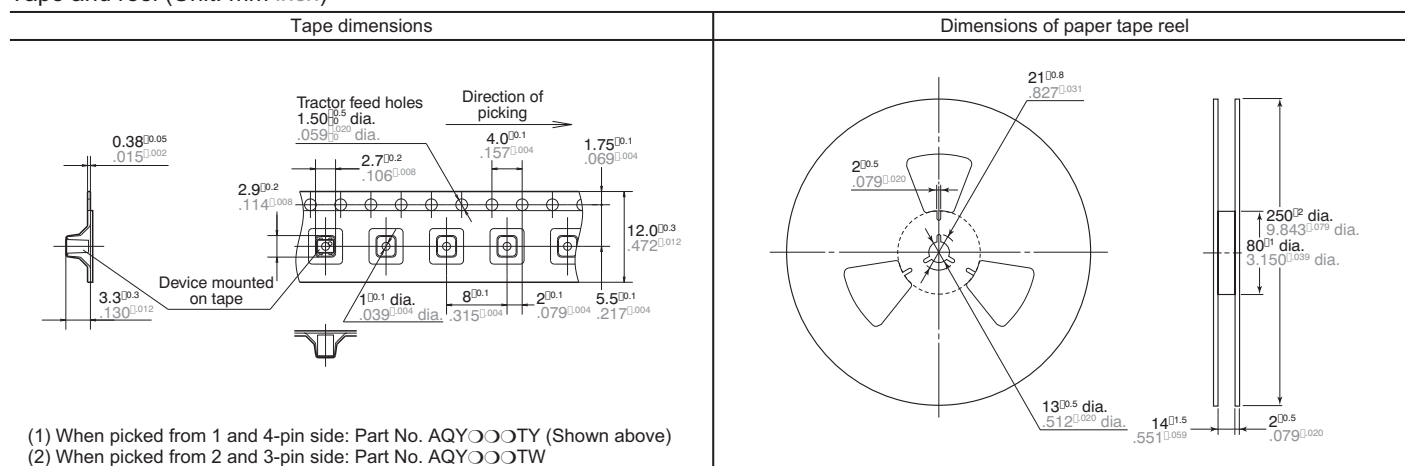

12. Transportation and storage

1) Extreme vibration during transport will damage the device. Handle the outer and inner boxes with care.

2) Storage under extreme conditions will cause soldering degradation, external appearance defects, and deterioration of the characteristics. The following storage conditions are recommended:

- Temperature: 0 to 45°C 32 to 113°F
- Humidity: Less than 70% R.H.

• Atmosphere: No harmful gasses such as sulfurous acid gas, minimal dust.

3) PhotoMOS implemented in VSSOP type are sensitive to moisture and come in sealed moisture-proof packages. Observe the following cautions on storage.

• After the moisture-proof package is unsealed, take the devices out of storage as soon as possible (within 1 month, less than 45°C 113°F/70% R.H.).

• If the devices are to be left in storage for a considerable period after the moisture-proof package has been unsealed, it is recommended to keep them in another

moisture-proof bag containing silica gel (within 3 months at the most).

*When thermal stress is applied when mounting with solder after the product has absorbed moisture, the water will evaporate, swelling will occur, and the inside of the package will become stressed. Since this can lead to bulging and cracking of the package surface, please be sure to be careful and follow the correct soldering conditions.

13. About the exposed terminals on the sides of the package

As shown in the following figure, part of the input and output frames are exposed on the sides of the package. Due to this, please be keep in mind the cautions listed below.

1) Shorting the exposed terminals may cause deterioration of the insulation between the inputs and outputs, and may damage the internal IC.

2) Since the exposed terminals are connected electrically to the internal element, please refer to the section "4. Deterioration and destruction caused by

discharge of static electricity", and implement sufficient measures to control static electricity.

3) When installing the devices in the vicinity, please keep in mind that if the exposed frames of adjacent devices get too close, a short between devices may occur.

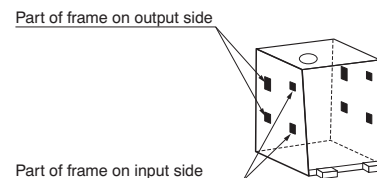

14. Regarding close installations

When this product is installed close to other parts, the ambient temperature may rise due to heating of the internal element when power is applied. Be sure to use with a reduced load current after testing under actual conditions, because the degree of temperature rise depends on the placement of the devices and conditions of use.

Panasonic

ideas for life

Micro-miniature SON package
Lower output capacitance
and on resistance (C×R5)
25V load voltage

PhotoMOS®
RF SON 1 Form A C×R5
(AQY221N3M)

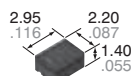

CAD Data

mm inch

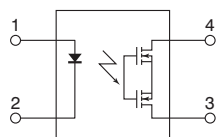

FEATURES

1. Super miniature SON* package contributes to space savings and high density mounting.

The SON type is a new PhotoMOS relay with approximately 43% the volume ratio of existing SSOP type. The super miniature leadless construction reduces the mounting area and enables high density mounting.

***Small Outline No-lead package**
 Reduced to approximately 43% volume ratio

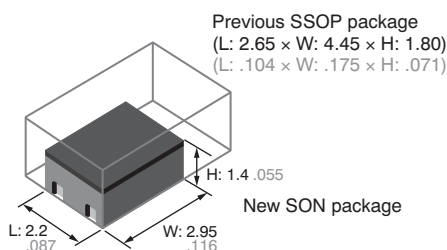

Area comparison (including leads)

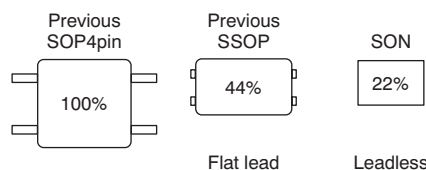

2. Lower output capacitance and on-resistance

Output capacitance (Cout): 1.1pF (typ.)
 On resistance (Ron): 5.5Ω (typ.)

3. High speed switching

Turn on time: 0.02ms (typ.)
 Turn off time: 0.02ms (typ.)

TYPICAL APPLICATIONS

Measuring and testing equipment

1. Testing equipment

IC tester, Semiconductor performance tester, Probe cards, etc.

2. Board tester

Bare board tester, In-circuit tester, Function tester, etc.

TYPES

	Output rating*1		Package	Tape and reel packing style*2		Packing quantity in tape and reel
	Load voltage	Load current		Picked from the 1 and 4-pin side	Picked from the 2 and 3-pin side	
AC/DC dual use	25 V	150 mA	SON	AQY221N3MY	AQY221N3MW	3,500 pcs.

Notes: *1 Indicate the peak AC and DC values.

*2 Only tape and reel package is available.

For space reasons, only "1N3" is marked on the product as the part number.

RATING

1. Absolute maximum ratings (Ambient temperature: 25°C 77°F)

Item		Symbol	AQY221N3M	Remarks
Input	LED forward current	I _F	50mA	
	LED reverse voltage	V _R	5V	
	Peak forward current	I _{FP}	1A	f=100 Hz, Duty factor=0.1%
	Power dissipation	P _{in}	75mW	
Output	Load voltage (peak AC)	V _L	25V	
	Continuous load current	I _L	0.15A	Peak AC, DC
	Power dissipation	P _{out}	250mW	
Total power dissipation		P _T	300mW	
I/O isolation voltage		V _{iso}	200V AC	
Operating temperature		T _{opr}	-40°C to +85°C -40°F to +185°F	Non-condensing at low temperatures
Storage temperature		T _{stg}	-40°C to +100°C -40°F to +212°F	

RF SON 1 Form A C×R5 (AQY221N3M)

2. Electrical characteristics (Ambient temperature: 25°C 77°F)

Item		Symbol	AQY221N3M	Condition	
Input	LED operate current	Typical	1.0 mA	$I_L = 80 \text{ mA}$	
		Maximum	3.0 mA		
	LED turn off current	Minimum	0.2 mA	$I_L = 80 \text{ mA}$	
		Typical	0.9 mA		
LED dropout voltage	Typical	V_F	1.35 V (1.14 V at $I_F = 5 \text{ mA}$)	$I_F = 50 \text{ mA}$	
	Maximum		1.5 V		
Output	On resistance	Typical	R_{on}	$I_F = 5 \text{ mA}$	
		Maximum		$I_L = 80 \text{ mA}$ Within 1 s on time	
	Output capacitance	Typical	C_{out}	1.1 pF	$I_F = 0 \text{ mA}$
		Maximum		1.5 pF	$V_B = 0 \text{ V}$ $f = 1 \text{ MHz}$
	Off state leakage current	Typical	I_{Leak}	0.01 nA	$I_F = 0 \text{ mA}$
Maximum		10 nA		$V_L = \text{Max.}$	
Transfer characteristics	Turn on time*	Typical	T_{on}	0.02 ms	
		Maximum		0.2 ms	$I_F = 5 \text{ mA}$ $V_L = 10 \text{ V}$ $R_L = 125\Omega$
	Turn off time*	Typical	T_{off}	0.02 ms	$I_F = 5 \text{ mA}$
		Maximum		0.2 ms	$V_L = 10 \text{ V}$ $R_L = 125\Omega$
	I/O capacitance	Typical	C_{iso}	0.8 pF	$f = 1 \text{ MHz}$
		Maximum		1.5 pF	$V_B = 0 \text{ V}$

Note: Variation possible through combinations of output capacitance and on resistance. For more information, please contact our sales office in your area.

*Turn on/Turn off time

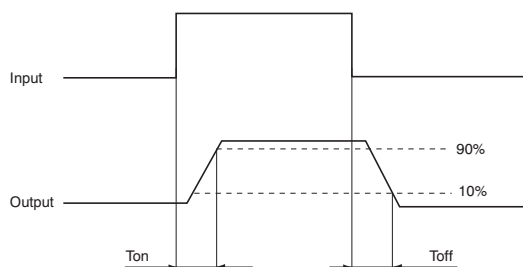

RECOMMENDED OPERATING CONDITIONS

Please obey the following conditions to ensure proper relay operation and resetting.

Item	Symbol	Recommended value	Unit
Input LED current	I_F	5	mA

■ For Dimensions, see page 61.

■ For Schematic and Wiring Diagrams, see page 64.

■ For Cautions for Use, see page 71.

■ These products are not designed for automotive use.

If you are considering to use these products for automotive applications, please contact your local Panasonic technical representative.

For more information, see page 80.

RF SON 1 Form A C×R5 (AQY221N3M)

REFERENCE DATA

1. Load current vs. ambient temperature characteristics

Allowable ambient temperature: -40°C to $+85^{\circ}\text{C}$
 -40°F to $+185^{\circ}\text{F}$

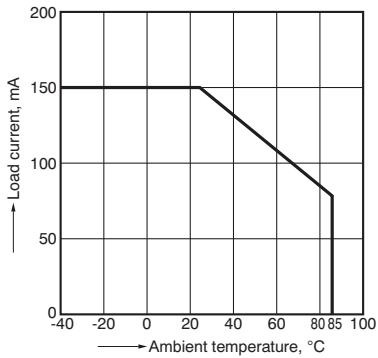

2. Load current vs. Load voltage characteristics

Ambient temperature: 25°C 77°F

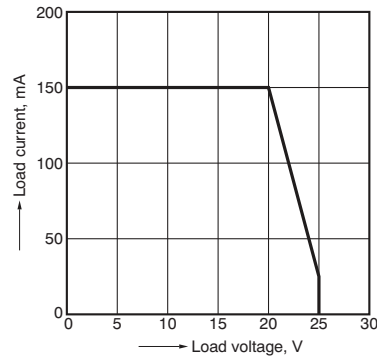

3. On resistance vs. ambient temperature characteristics

Measured portion: between terminals 3 and 4
 LED current: 5 mA; Load voltage: 10V (DC);
 Load current: 80mA (DC)

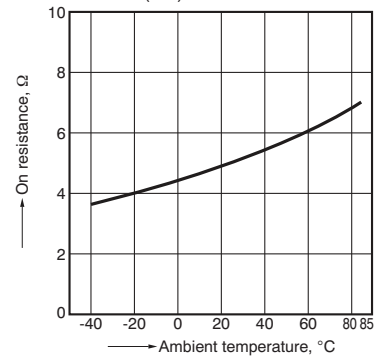

4. Turn on time vs. ambient temperature characteristics

Measured portion: between terminals 3 and 4
 LED current: 5 mA; Load voltage: 10V (DC);
 Continuous load current: 80mA (DC)

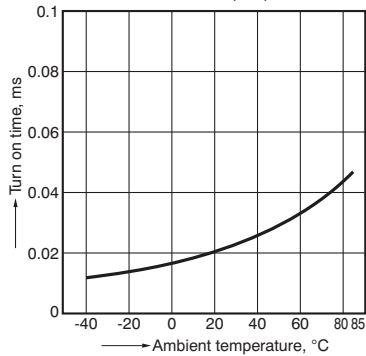

5. Turn off time vs. ambient temperature characteristics

Measured portion: between terminals 3 and 4
 LED current: 5 mA; Load voltage: 10V (DC);
 Continuous load current: 80mA (DC)

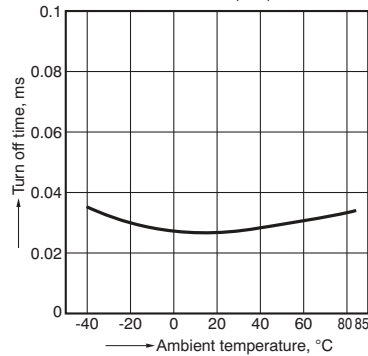

6. LED operate current vs. ambient temperature characteristics

Measured portion: between terminals 3 and 4
 Load voltage: 10V (DC);
 Continuous load current: 80mA (DC)

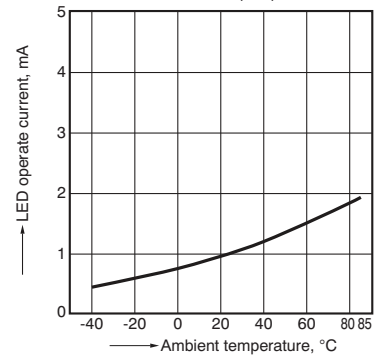

7. LED turn off current vs. ambient temperature characteristics

Measured portion: between terminals 3 and 4
 Load voltage: 10V (DC);
 Continuous load current: 80mA (DC)

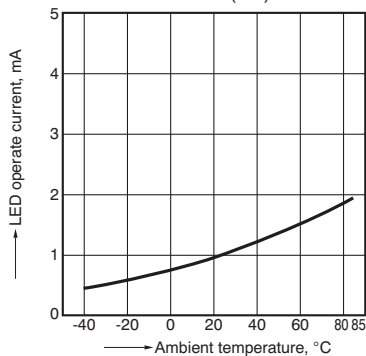

8. LED dropout voltage vs. ambient temperature characteristics

LED current: 5 to 50 mA

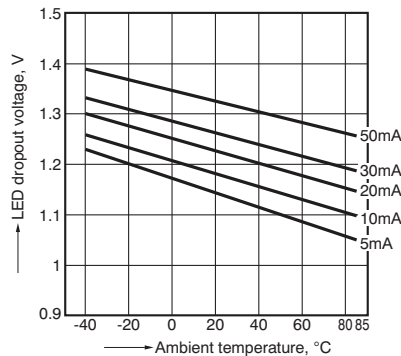

9. Current vs. voltage characteristics of output at MOS portion

Measured portion: between terminals 3 and 4
 Ambient temperature: 25°C 77°F

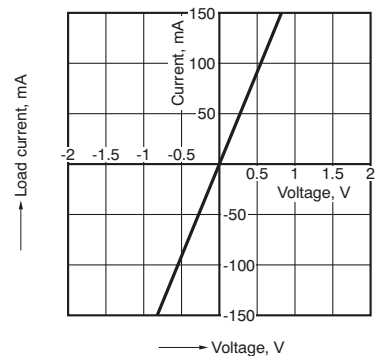

RF SON 1 Form A C×R5 (AQY221N3M)

10. Off state leakage current vs. load voltage characteristics

Measured portion: between terminals 3 and 4
Ambient temperature: 25°C 77°F

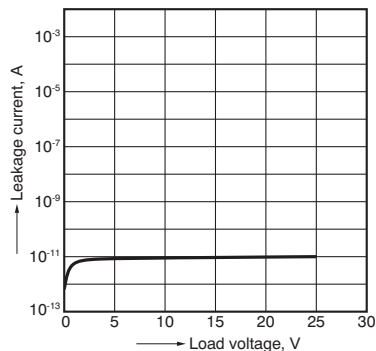

11. Turn on time vs. LED forward current characteristics

Measured portion: between terminals 3 and 4
Load voltage: 10V (DC); Continuous load current: 80mA (DC); Ambient temperature: 25°C 77°F

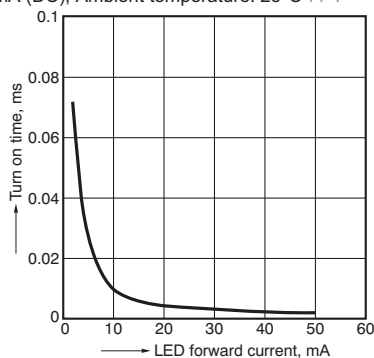

12. Turn off time vs. LED forward current characteristics

Measured portion: between terminals 3 and 4
Load voltage: 10V (DC); Continuous load current: 80mA (DC); Ambient temperature: 25°C 77°F

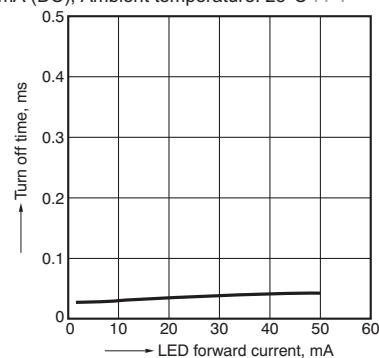

13. Output capacitance vs. applied voltage characteristics

Measured portion: between terminals 3 and 4
Frequency: 1 MHz, 30m Vrms; Ambient temperature: 25°C 77°F

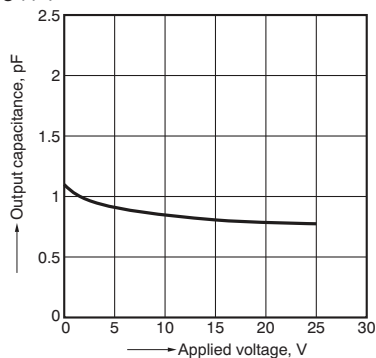

14. Isolation vs. frequency characteristics (50Ω impedance)

Measured portion: between terminals 3 and 4
Ambient temperature: 25°C 77°F

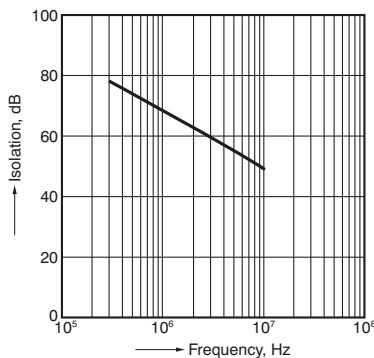

15. Insertion loss vs. frequency characteristics (50Ω impedance)

Measured portion: between terminals 3 and 4
Ambient temperature: 25°C 77°F

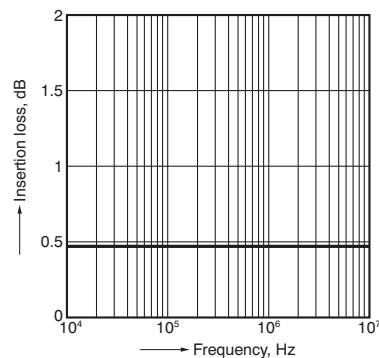

16. On resistance distribution

Measured portion: between terminals 3 and 4
Continuous load current: 80mA (DC), n: 50pcs.
Ambient temperature: 25°C 77°F

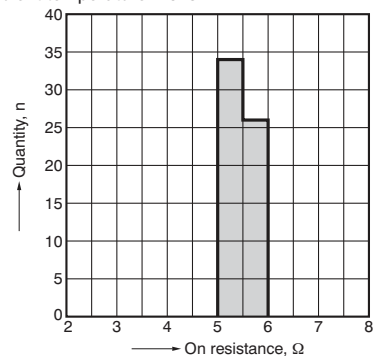

17. Turn on time distribution

Load voltage: 10V (DC)
Continuous load current: 80mA (DC), n: 50pcs.
Ambient temperature: 25°C 77°F

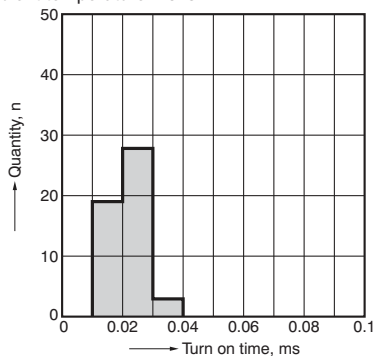

18. Turn off time distribution

Load voltage: 10V (DC)
Continuous load current: 80mA (DC), n: 50pcs.
Ambient temperature: 25°C 77°F

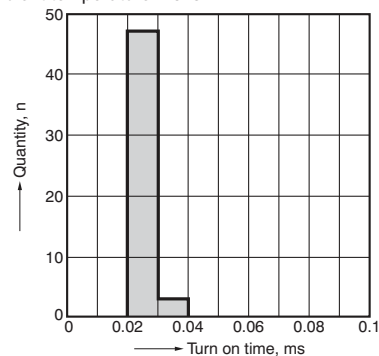

19. LED operate current distribution

Load voltage: 10V (DC)
Continuous load current: 80mA (DC), n: 50pcs.
Ambient temperature: 25°C 77°F

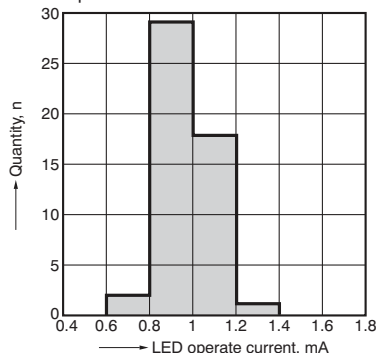

Panasonic

ideas for life

Super miniature SSOP
Lower output capacitance
and on resistance (C×R5)
Load voltage 25V

PhotoMOS®
RF SSOP 1 Form A C×R5
(AQY221N3V)

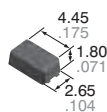

CAD Data

mm inch

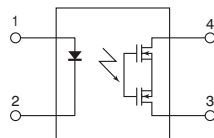

FEATURES

1. Reduced package size

Lower surface has been reduced 60% and mounting space 40% compared to conventional SOP4-pin type.

2. Lower output capacitance and on-resistance

Output capacitance (Cout): 1.0pF (typ.)
 ON resistance (Ron): 5.5Ω (typ.)

3. Mounting space has been reduced and output signals have been improved by using new flat lead terminals.

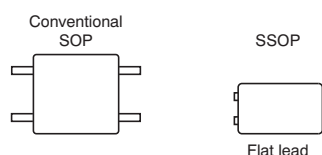

4. High speed switching

Turn on time: 0.02ms (typ.)

Turn off time: 0.02ms (typ.)

TYPICAL APPLICATIONS

1. Measuring and testing equipment

IC tester, Liquid crystal driver tester, Semiconductor performance tester, Board tester, etc.

2. Medical equipment

Ultrasonic wave diagnostic machine

3. Multi-point recorder

Warping, Thermo couple, etc.

4. Telecommunication and broadcasting equipment

TYPES

	Output rating*1		Package	Tape and reel packing style		Packing quantity in tape and reel*2
	Load voltage	Load current		Picked from the 1/4-pin side	Picked from the 2/3-pin side	
AC/DC dual use	25 V	150 mA	SSOP	AQY221N3VY	AQY221N3VW	3,500 pcs.

Notes: *1 Indicate the peak AC and DC values.

*2 Tape and reel is the standard packing style for SSOP.

For space reasons, only "N3V" is marked on the product as the part number. The three initial letters of the part number "AQY", and the package (SSOP) indicator "V" and the packing style indicator "Y" or "W" are not marked on the relay.

RATING

1. Absolute maximum ratings (Ambient temperature: 25°C 77°F)

Item		Symbol	AQY221N3V	Remarks
Input	LED forward current	I _F	50mA	
	LED reverse voltage	V _R	5V	
	Peak forward current	I _{FP}	1A	f=100 Hz, Duty factor=0.1%
	Power dissipation	P _{in}	75mW	
Output	Load voltage (peak AC)	V _L	25V	
	Continuous load current	I _L	0.15A	Peak AC, DC
	Peak load current	I _{peak}	0.4A	100 ms (1 shot), V _L = DC
	Power dissipation	P _{out}	250mW	
Total power dissipation		P _T	300mW	
I/O isolation voltage		V _{iso}	1,500V AC	
Temperature limits	Operating	T _{opr}	-40°C to +85°C -40°F to +185°F	Non-condensing at low temperatures
	Storage	T _{stg}	-40°C to +100°C -40°F to +212°F	

RF SSOP 1 Form A C×R5 (AQY221N3V)

2. Electrical characteristics (Ambient temperature: 25°C 77°F)

Item		Symbol	AQY221N3V	Condition
Input	LED operate current	Typical	1.0 mA	$I_L = 80 \text{ mA}$
		Maximum	3.0 mA	
	LED turn off current	Minimum	0.2 mA	$I_L = 80 \text{ mA}$
		Typical	0.9 mA	
LED dropout voltage	Typical	V_F	1.35 V (1.14 V at $I_F = 5 \text{ mA}$)	$I_F = 50 \text{ mA}$
	Maximum		1.5 V	
Output	On resistance	Typical	5.5Ω	$I_F = 5 \text{ mA}$, $I_L = 80 \text{ mA}$ Within 1 s on time
		Maximum	7.5Ω	
	Output capacitance	Typical	1.0 pF	$I_F = 0 \text{ mA}$, $V_B = 0 \text{ V}$ $f = 1 \text{ MHz}$
		Maximum	1.5 pF	
	Off state leakage current	Typical	0.01 nA	$I_F = 0 \text{ mA}$ $V_L = \text{Max.}$
		Maximum	10 nA	
Transfer characteristics	Turn on time*	Typical	0.02 ms	$I_F = 5 \text{ mA}$, $V_L = 10 \text{ V}$ $R_L = 125 \Omega$
		Maximum	0.2 ms	
	Turn off time*	Typical	0.02 ms	$I_F = 5 \text{ mA}$, $V_L = 10 \text{ V}$ $R_L = 125 \Omega$
		Maximum	0.2 ms	
	I/O capacitance	Typical	0.8 pF	$f = 1 \text{ MHz}$ $V_B = 0 \text{ V}$
		Maximum	1.5 pF	
Initial I/O isolation resistance	Minimum	R_{iso}	1,000M Ω	500V DC

Note: Variation possible through combinations of output capacitance and on resistance. For more information, please contact our sales office in your area.

*Turn on/Turn off time

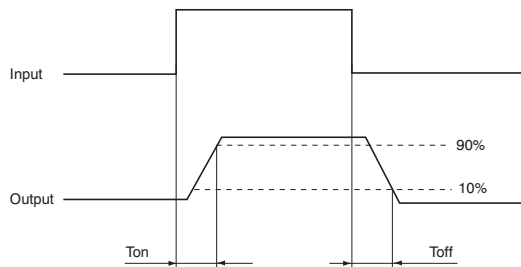

RECOMMENDED OPERATING CONDITIONS

Please obey the following conditions to ensure proper relay operation and resetting.

Item	Symbol	Recommended value	Unit
Input LED current	I_F	5	mA

■ For Dimensions, see page 62.

■ For Schematic and Wiring Diagrams, see page 64.

■ For Cautions for Use, see page 71.

■ These products are not designed for automotive use.

If you are considering to use these products for automotive applications, please contact your local Panasonic technical representative.

For more information, see page 80.

RF SSOP 1 Form A C×R5 (AQY221N3V)

REFERENCE DATA

1. Load current vs. ambient temperature characteristics

Allowable ambient temperature: -40°C to $+85^{\circ}\text{C}$
 -40°F to $+185^{\circ}\text{F}$

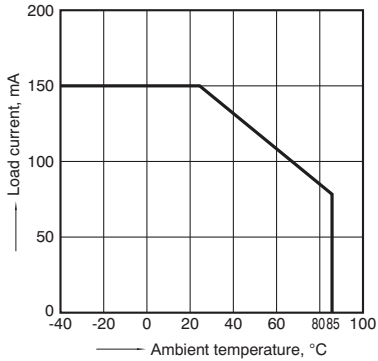

2. Load current vs. Load voltage characteristics

Ambient temperature: 25°C 77°F

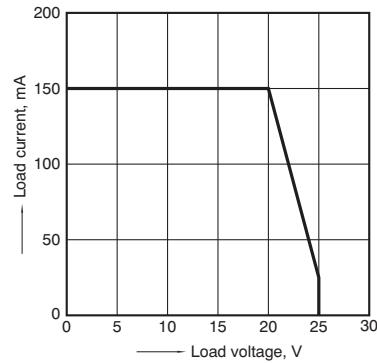

3. On resistance vs. ambient temperature characteristics

Measured portion: between terminals 3 and 4
 LED current: 5 mA; Load voltage: 10V (DC);
 Load current: 80mA (DC)

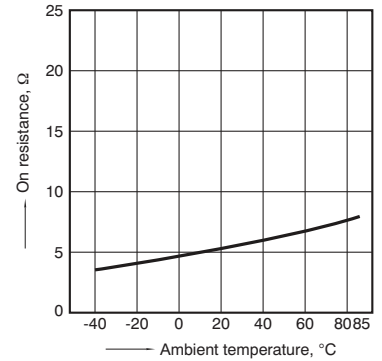

4. Turn on time vs. ambient temperature characteristics

Measured portion: between terminals 3 and 4
 LED current: 5 mA; Load voltage: 10V (DC);
 Continuous load current: 80mA (DC)

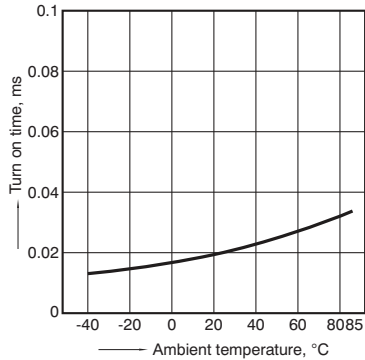

5. Turn off time vs. ambient temperature characteristics

Measured portion: between terminals 3 and 4
 LED current: 5 mA; Load voltage: 10V (DC);
 Continuous load current: 80mA (DC)

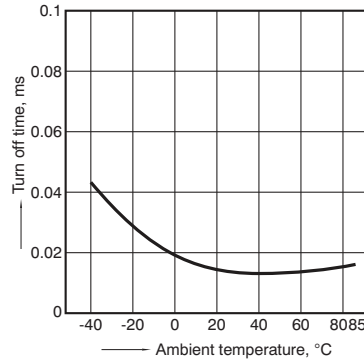

6. LED operate current vs. ambient temperature characteristics

Measured portion: between terminals 3 and 4
 Load voltage: 10V (DC);
 Continuous load current: 80mA (DC)

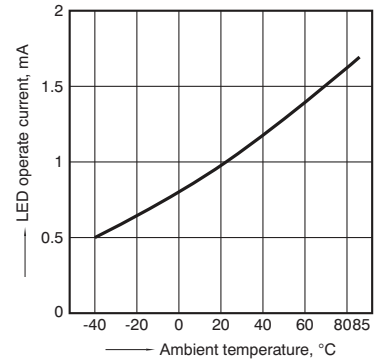

7. LED turn off current vs. ambient temperature characteristics

Measured portion: between terminals 3 and 4
 Load voltage: 10V (DC);
 Continuous load current: 80mA (DC)

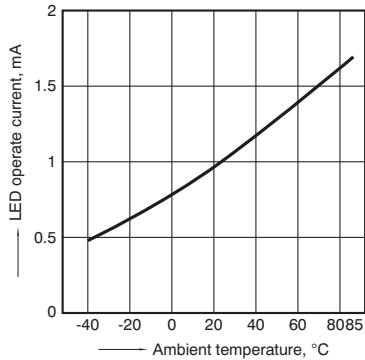

8. LED dropout voltage vs. ambient temperature characteristics

LED current: 5 to 50 mA

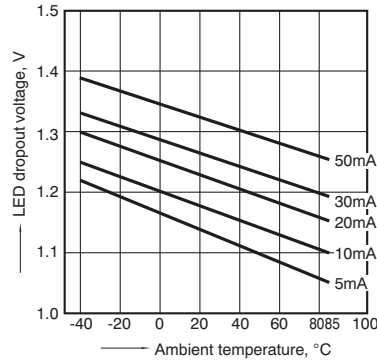

9. Current vs. voltage characteristics of output at MOS portion

Measured portion: between terminals 3 and 4
 Ambient temperature: 25°C 77°F

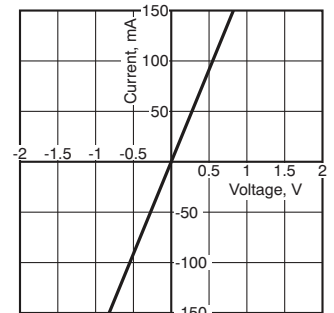

RF SSOP 1 Form A C×R5 (AQY221N3V)

10. Off state leakage current vs. load voltage characteristics

Measured portion: between terminals 3 and 4
Ambient temperature: 25°C 77°F

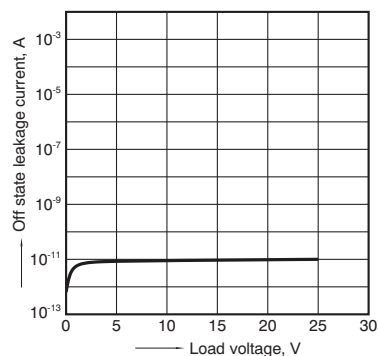

11. Turn on time vs. LED forward current characteristics

Measured portion: between terminals 3 and 4
Load voltage: 10V (DC); Continuous load current: 80mA (DC); Ambient temperature: 25°C 77°F

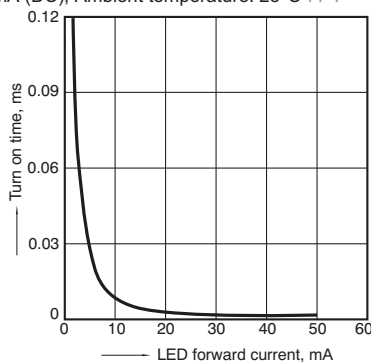

12. Turn off time vs. LED forward current characteristics

Measured portion: between terminals 3 and 4
Load voltage: 10V (DC); Continuous load current: 80mA (DC); Ambient temperature: 25°C 77°F

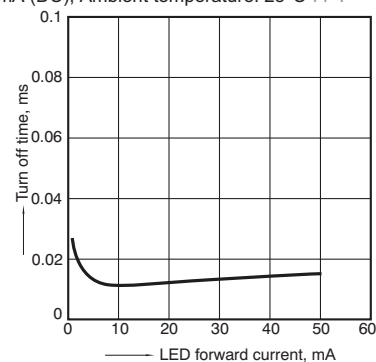

13. Output capacitance vs. applied voltage characteristics

Measured portion: between terminals 3 and 4
Frequency: 1 MHz, 30m Vrms; Ambient temperature: 25°C 77°F

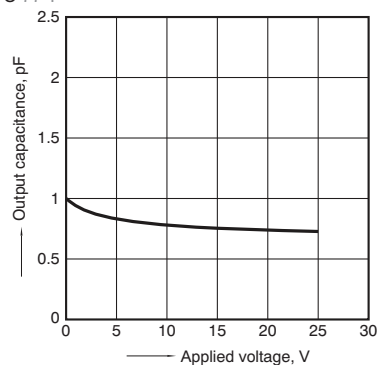

14. Isolation vs. frequency characteristics (50Ω impedance)

Measured portion: between terminals 3 and 4
Ambient temperature: 25°C 77°F

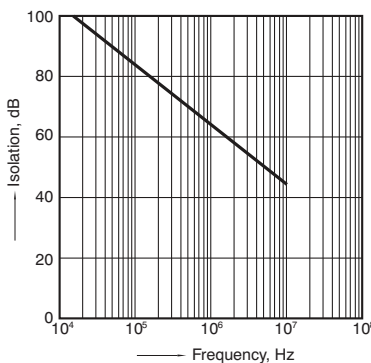

15. Insertion loss vs. frequency characteristics (50Ω impedance)

Measured portion: between terminals 3 and 4
Ambient temperature: 25°C 77°F

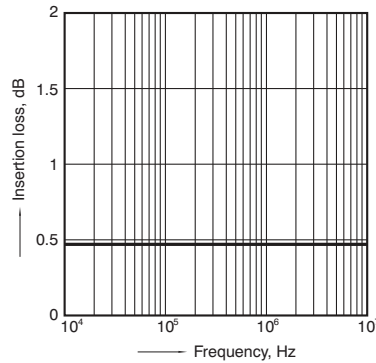

16. On resistance distribution

Measured portion: between terminals 3 and 4
Continuous load current: 80mA (DC)
Ambient temperature: 25°C 77°F

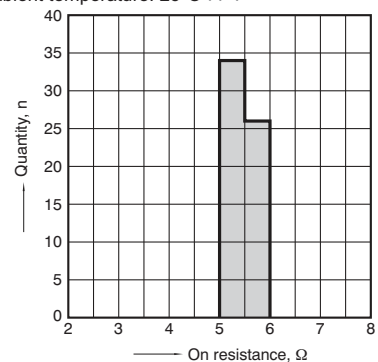

17. Turn on time distribution

Load voltage: 10V (DC)
Continuous load current: 80mA (DC)
Ambient temperature: 25°C 77°F

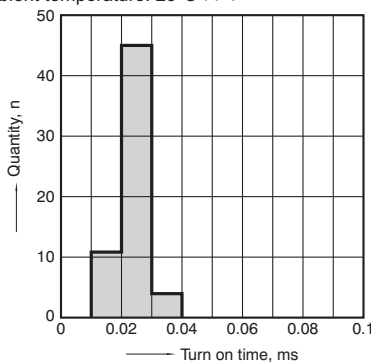

18. Turn off time distribution

Load voltage: 10V (DC)
Continuous load current: 80mA (DC)
Ambient temperature: 25°C 77°F

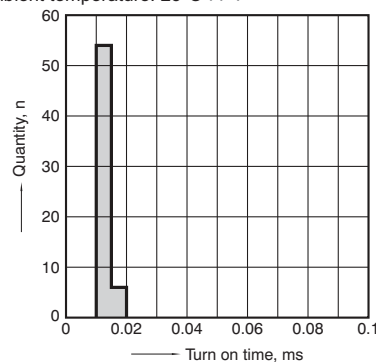

19. LED operate current distribution

Load voltage: 10V (DC)
Continuous load current: 80mA (DC)
Ambient temperature: 25°C 77°F

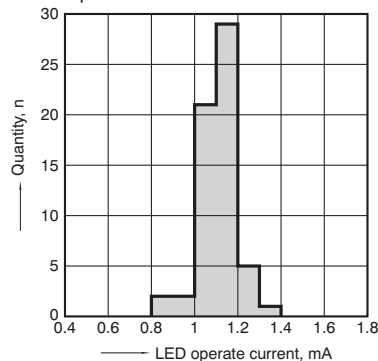

Panasonic

ideas for life

Micro-miniature SON package
Lower output capacitance
and on resistance (C×R10)
40V load voltage

PhotoMOS®
RF SON 1 Form A C×R10
(AQY221○2M)

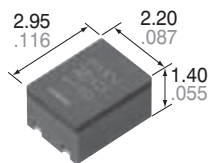

CAD Data

mm inch

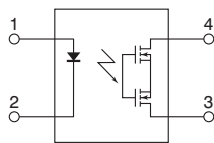

FEATURES

1. Super miniature SON* package contributes to space savings and high density mounting.

The SON type is a new PhotoMOS relay with approximately 43% the volume ratio of existing SSOP type. The super miniature leadless construction reduces the mounting area and enables high density mounting.

*Small Outline No-lead package

Reduced to approximately 43% volume ratio

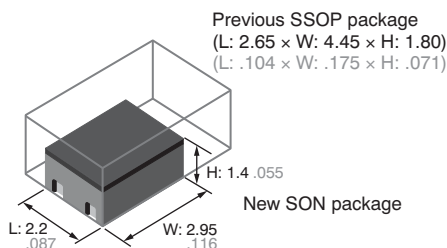

Area comparison (including leads)

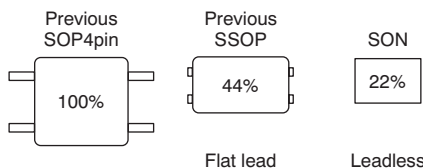

2. Both low on-resistance (R type) and low capacitance (C type) available at C×R10

- R type: On resistance 0.8Ω (typ.)
Output capacitance 14pF (typ.)
- C type: On resistance 9.5Ω (typ.)
Output capacitance 1.1pF (typ.)

TYPICAL APPLICATIONS

1. Measuring equipment

IC tester, Probe cards, board tester and other testing equipment

2. Telecommunication or broadcasting equipment

3. Medical equipment

TYPES

	Type	Output rating*1		Package	Tape and reel packing style*2		Packing quantity in tape and reel
		Load voltage	Load current		Picked from the 1 and 4-pin side	Picked from the 2 and 3-pin side	
AC/DC dual use	Low on-resistance (R type)	40 V	250 mA	SON	AQY221R2MY	AQY221R2MW	3,500 pcs.
	Low capacitance (C type)	40 V	120 mA		AQY221N2MY	AQY221N2MW	

Notes: *1 Indicate the peak AC and DC values.

*2 Only tape and reel package is available.

For space reasons, only "1R2" or "1N2" is marked on the product as the part number.

RATING

1. Absolute maximum ratings (Ambient temperature: 25°C 77°F)

Item		Symbol	AQY221R2M	AQY221N2M	Remarks
Input	LED forward current	I_F	50mA		
	LED reverse voltage	V_R	5V		
	Peak forward current	I_{FP}	1A		f=100 Hz, Duty factor=0.1%
	Power dissipation	P_{in}	75mW		
Output	Load voltage (peak AC)	V_L	40V	40V	
	Continuous load current	I_L	0.25A	0.12A	Peak AC, DC
	Peak load current	I_{peak}	0.75A	—	100ms (1shot), $V_L=DC$
	Power dissipation	P_{out}	250mW		
Total power dissipation		P_T	300mW		
I/O isolation voltage		V_{iso}	200V AC		
Operating temperature		T_{opr}	-40°C to +85°C -40°F to +185°F		Non-condensing at low temperatures
Storage temperature		T_{stg}	-40°C to +100°C -40°F to +212°F		

RF SON 1 Form A C×R10 (AQY221○2M)

2. Electrical characteristics (Ambient temperature: 25°C 77°F)

Item			Symbol	R type	C type	Condition	
				AQY221R2M	AQY221N2M		
Input	LED operate current	Typical	I_{Fon}	0.8 mA	1.0 mA	R type: $I_L = 250$ mA C type: $I_L = 80$ mA	
		Maximum		3.0 mA			
	LED turn off current	Minimum	I_{Foff}	0.2 mA			
		Typical		0.7 mA	0.9 mA		
LED dropout voltage	Typical	V_F	1.35 V (1.14 V at $I_F = 5$ mA)		$I_F = 50$ mA		
	Maximum		1.5 V				
Output	On resistance	Typical	R_{on}	0.8Ω	9.5Ω	R type: $I_F = 5$ mA, $I_L = 250$ mA C type: $I_F = 5$ mA, $I_L = 80$ mA Within 1 s on time	
		Maximum		1.25Ω	12.5Ω		
	Output capacitance	Typical	C_{out}	14 pF	1.1 pF	$I_F = 0$ mA $V_B = 0$ V $f = 1$ MHz	
		Maximum		18 pF	1.5 pF		
	Off state leakage current	Typical	I_{Leak}	0.01 nA		$I_F = 0$ mA $V_L = Max.$	
		Maximum		10 nA			
Transfer characteristics	Turn on time*	Typical	T_{on}	0.2 ms	0.02 ms	R type: $I_F = 5$ mA, $V_L = 10$ V, $R_L = 40$ Ω C type: $I_F = 5$ mA, $V_L = 10$ V, $R_L = 125$ Ω	
		Maximum		0.5 ms	0.2 ms		
	Turn off time*	Typical	T_{off}	0.04 ms	0.02 ms		
		Maximum		0.2 ms			
	I/O capacitance	Typical	C_{iso}	0.8 pF			$f = 1$ MHz $V_B = 0$ V
		Maximum		1.5 pF			

Note: Variation possible through combinations of output capacitance and on resistance. For more information, please contact our sales office in your area.

*Turn on/Turn off time

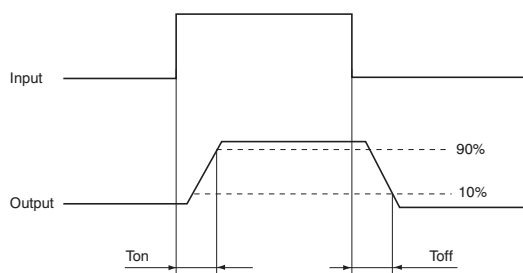

RECOMMENDED OPERATING CONDITIONS

Please obey the following conditions to ensure proper relay operation and resetting.

Item	Symbol	Recommended value	Unit
Input LED current	I_F	5	mA

■ For Dimensions, see page 61.

■ For Schematic and Wiring Diagrams, see page 64.

■ For Cautions for Use, see page 71.

■ These products are not designed for automotive use.

If you are considering to use these products for automotive applications, please contact your local Panasonic technical representative.

For more information, see page 80.

RF SON 1 Form A C×R10 (AQY221○2M)

REFERENCE DATA

1. Load current vs. ambient temperature characteristics

Allowable ambient temperature: -40°C to $+85^{\circ}\text{C}$
 -40°F to $+185^{\circ}\text{F}$

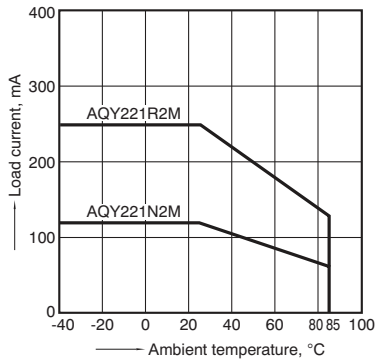

2. Load current vs. Load voltage characteristics

Ambient temperature: 25°C 77°F

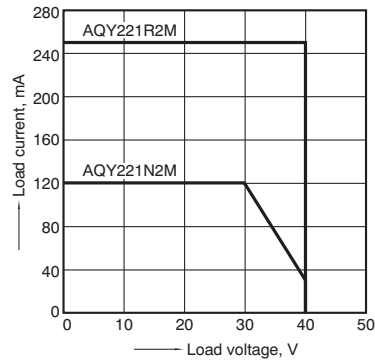

3. On resistance vs. ambient temperature characteristics

Measured portion: between terminals 3 and 4;
 LED current: 5 mA; Load voltage: 10V (DC); Load current: 250mA (DC) R type, 80mA (DC) C type

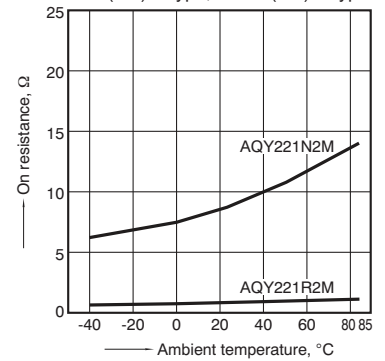

4. Turn on time vs. ambient temperature characteristics

Measured portion: between terminals 3 and 4; LED current: 5 mA; Load voltage: 10V (DC); Continuous load current: 250mA (DC) R type, 80mA (DC) C type

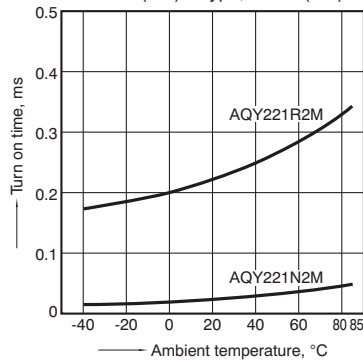

5. Turn off time vs. ambient temperature characteristics

Measured portion: between terminals 3 and 4; LED current: 5 mA; Load voltage: 10V (DC); Continuous load current: 250mA (DC) R type, 80mA (DC) C type

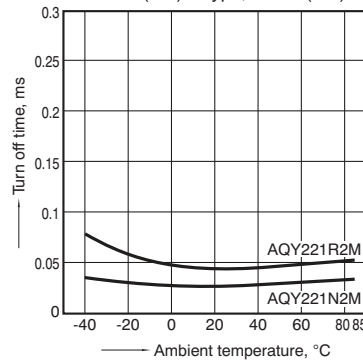

6. LED operate current vs. ambient temperature characteristics

Measured portion: between terminals 3 and 4; Load voltage: 10V (DC); Continuous load current: 250mA (DC) R type, 80mA (DC) C type

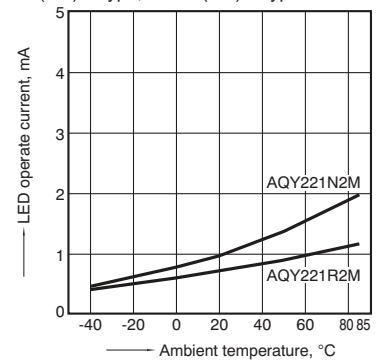

7. LED turn off current vs. ambient temperature characteristics

Measured portion: between terminals 3 and 4; Load voltage: 10V (DC); Continuous load current: 250mA (DC) R type, 80mA (DC) C type

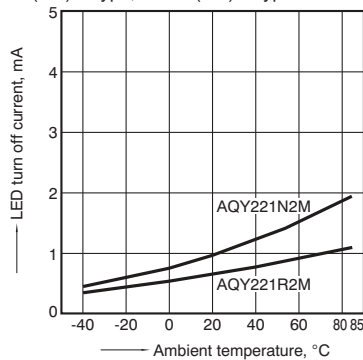

8. LED dropout voltage vs. ambient temperature characteristics

LED current: 5 to 50 mA

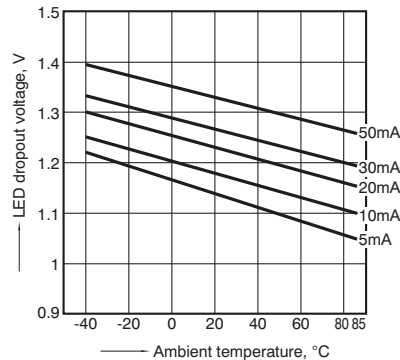

9. Current vs. voltage characteristics of output at MOS portion

Measured portion: between terminals 3 and 4
 Ambient temperature: 25°C 77°F

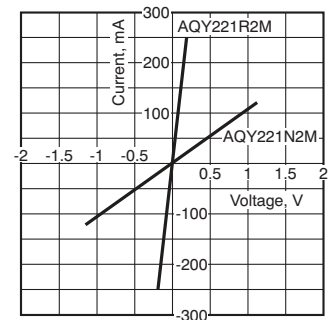

RF SON 1 Form A C×R10 (AQY221○2M)

10. Off state leakage current vs. load voltage characteristics

Measured portion: between terminals 3 and 4
Ambient temperature: 25°C 77°F

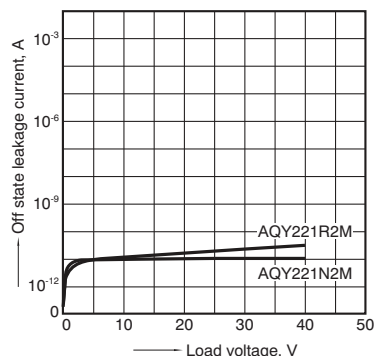

11. Turn on time vs. LED forward current characteristics

Measured portion: between terminals 3 and 4; Load voltage: 10V (DC); Continuous load current: 250mA (DC) R type, 80mA (DC) C type; Ambient temperature: 25°C 77°F

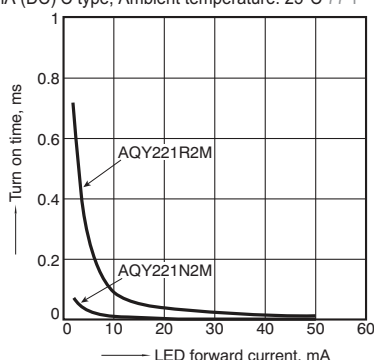

12. Turn off time vs. LED forward current characteristics

Measured portion: between terminals 3 and 4; Load voltage: 10V (DC); Continuous load current: 250mA (DC) R type, 80mA (DC) C type; Ambient temperature: 25°C 77°F

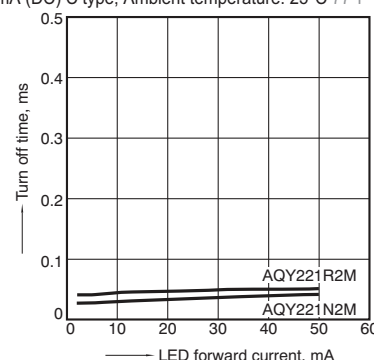

13. Output capacitance vs. applied voltage characteristics

Measured portion: between terminals 3 and 4;
Frequency: 1 MHz, 30m Vrms; Ambient temperature: 25°C 77°F

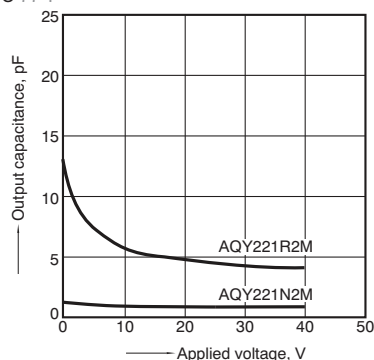

14. Isolation vs. frequency characteristics (50Ω impedance)

Measured portion: between terminals 3 and 4
Ambient temperature: 25°C 77°F

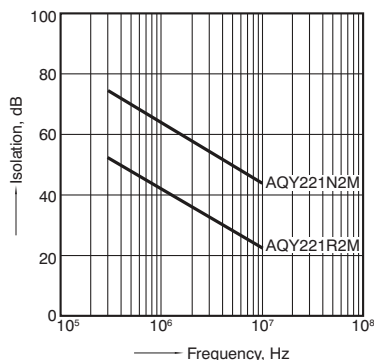

15. Insertion loss vs. frequency characteristics (50Ω impedance)

Measured portion: between terminals 3 and 4
Ambient temperature: 25°C 77°F

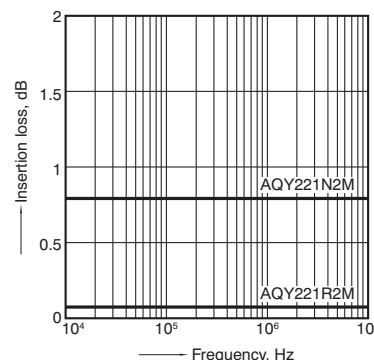

16-(1) On resistance distribution

Sample: AQY221R2M; Measured portion: between terminals 3 and 4; Continuous load current: 250mA (DC) R type, 80mA (DC) C type, n: 50pcs.
Ambient temperature: 25°C 77°F

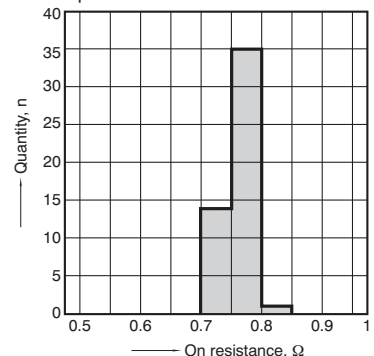

16-(2) On resistance distribution

Sample: AQY221N2M; Measured portion: between terminals 3 and 4; Continuous load current: 250mA (DC) R type, 80mA (DC) C type, n: 50pcs.
Ambient temperature: 25°C 77°F

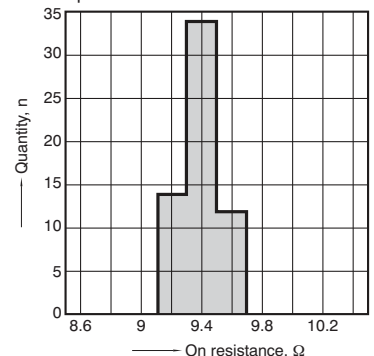

RF SON 1 Form A C×R10 (AQY221○2M)

17-(1) Turn on time distribution

Sample: AQY221R2M; Load voltage: 10V (DC)
 Continuous load current: 250mA (DC) R type, 80mA
 (DC) C type, n: 50pcs.

Ambient temperature: 25°C 77°F

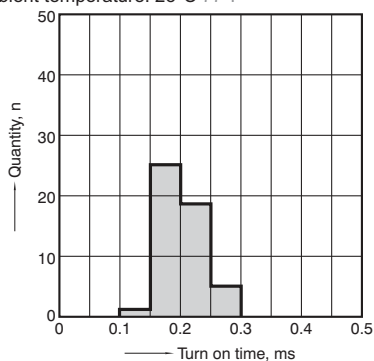

17-(2) Turn on time distribution

Sample: AQY221N2M; Load voltage: 10V (DC)
 Continuous load current: 250mA (DC) R type, 80mA
 (DC) C type, n: 50pcs.

Ambient temperature: 25°C 77°F

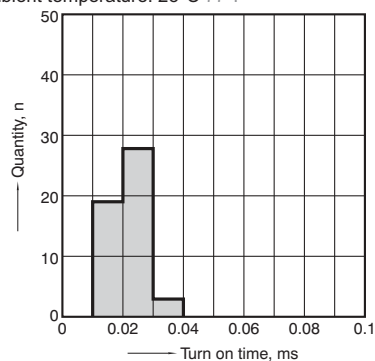

18-(1) Turn off time distribution

Sample: AQY221R2M; Load voltage: 10V (DC)
 Continuous load current: 250mA (DC) R type, 80mA
 (DC) C type, n: 50pcs.

Ambient temperature: 25°C 77°F

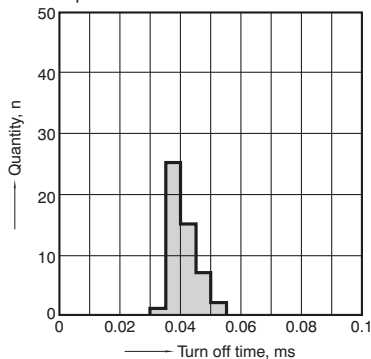

18-(2) Turn off time distribution

Sample: AQY221N2M; Load voltage: 10V (DC)
 Continuous load current: 250mA (DC) R type, 80mA
 (DC) C type, n: 50pcs.

Ambient temperature: 25°C 77°F

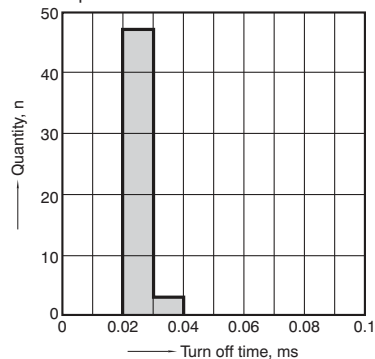

19-(1) LED operate current distribution

Sample: AQY221R2M; Load voltage: 10V (DC)
 Continuous load current: 250mA (DC) R type, 80mA
 (DC) C type, n: 50pcs.

Ambient temperature: 25°C 77°F

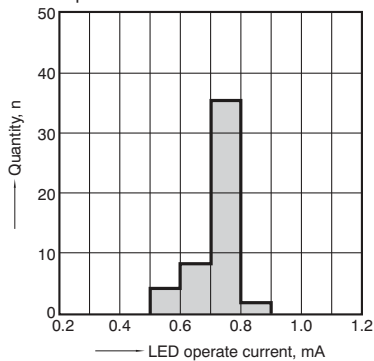

19-(2) LED operate current distribution

Sample: AQY221N2M; Load voltage: 10V (DC)
 Continuous load current: 250mA (DC) R type, 80mA
 (DC) C type, n: 50pcs.

Ambient temperature: 25°C 77°F

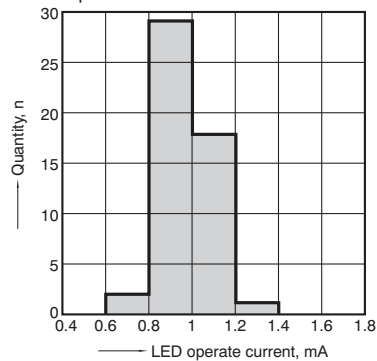

Panasonic

ideas for life

Micro-miniature SSOP
Lower output capacitance
and on resistance (C×R10)
40 V load voltage

PhotoMOS®
RF SSOP 1 Form A C×R10
(AQY221○○V)



CAD Data

mm inch

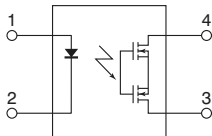

FEATURES

1. Micro-miniature package (SSOP) using a new flat lead terminal shape
 Compared to previous models (SOP 4-pin), mounting area can be reduced by approximately 56%*. This contributes to improved output signal transit characteristics.

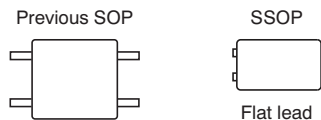

*Comparison of area of SSOP and SOP 4-pin (including leads).

2. Full lineup with C×R10

Lineup includes three types with superior electrical performance of C×R10. R type and C type, respectively, feature greatly reduced on resistance and output capacitance.

		On resistance (Typical)	Output capacitance (Typical)
R type	AQY221R4V	0.55Ω	24pF
	AQY221R2V	0.75Ω	12.5pF
C type	AQY221N2V	9.5Ω	1.0pF

TYPICAL APPLICATIONS

- Measuring and testing equipment**
Semiconductor testing equipment, Probe cards, Datalogger, Board tester and other testing equipment
- Telecommunication and broadcasting equipment**
- Medical equipment**

TYPES

	Type	Output rating*1		Package	Tape and reel packing style*2		Packing quantity in tape and reel
		Load voltage	Load current		Picked from the 1 and 4-pin side	Picked from the 2 and 3-pin side	
AC/DC dual use	Low on-resistance (R type)	40 V	500 mA	SSOP	AQY221R4VY	AQY221R4VW	3,500 pcs.
		40 V	250 mA		AQY221R2VY	AQY221R2VW	
	Low capacitance (C type)	40 V	120 mA		AQY221N2VY	AQY221N2VW	

Notes: *1 Indicate the peak AC and DC values.

*2 Tape and reel is the standard packing style for SSOP.

For space reasons, the three initial letters of the part number "AQY", the package (SSOP) indication "V", and the packaging style "Y" or "W" are not marked on the relay. (Ex. the label for product number AQY221R4VY is 221R4)

*3 For types with a built-in resistor, see page 200.

RATING

1. Absolute maximum ratings (Ambient temperature: 25°C 77°F)

Item	Symbol	R type		C type	Remarks
		AQY221R4V	AQY221R2V	AQY221N2V	
Input	LED forward current	50mA			
	LED reverse voltage	5V			
	Peak forward current	1A			f=100 Hz, Duty factor=0.1%
	Power dissipation	75mW			
Output	Load voltage (peak AC)	40V			
	Continuous load current	0.5A	0.25A	0.12A	Peak AC, DC
	Peak load current	1A	0.75A	0.3A	100ms (1shot), V _L =DC
	Power dissipation	250mW			
Total power dissipation	P _T	300mW			
I/O isolation voltage	V _{iso}	1,500V AC			
Operating temperature	T _{opr}	-40°C to +85°C -40°F to +185°F			Non-condensing at low temperatures
Storage temperature	T _{stg}	-40°C to +100°C -40°F to +212°F			

RF SSOP 1 Form A CxR10 (AQY221○○V)

2. Electrical characteristics (Ambient temperature: 25°C 77°F)

Item		Symbol	R type		C type	Condition	
			AQY221R4V	AQY221R2V	AQY221N2V		
Input	LED operate current	Typical	0.9 mA		1.0 mA	AQY221R4V: I _L = 500 mA AQY221R2V: I _L = 250 mA AQY221N2V: I _L = 80 mA	
		Maximum	3.0 mA				
	LED turn off current	Minimum	0.1 mA		0.2 mA		
		Typical	0.8 mA		0.9 mA		
LED dropout voltage*1	Typical	1.35 V (1.14 V at I _F = 5 mA)			I _F = 50 mA		
	Maximum	1.5 V					
Output	On resistance	Typical	0.55Ω	0.75Ω	9.5Ω	AQY221R4V: I _F = 5 mA, I _L = 500 mA AQY221R2V: I _F = 5 mA, I _L = 250 mA AQY221N2V: I _F = 5 mA, I _L = 80 mA Within 1 s on time	
		Maximum	1Ω	1.25Ω	12.5Ω		
	Output capacitance	Typical	24 pF	12.5 pF	1.0 pF		
		Maximum	30 pF	18 pF	1.5 pF		
Off state leakage current	Typical	0.02 nA		0.01 nA	I _F = 0 mA, V _L = Max.		
	Maximum	10 nA					
Transfer characteristics	Turn on time*2	Typical	0.25 ms	0.10 ms	0.20 ms	AQY221R4V: I _F = 5 mA, V _L = 10 V, R _L = 20Ω AQY221R2V: I _F = 5 mA, V _L = 10 V, R _L = 40Ω AQY221N2V: I _F = 5 mA, V _L = 10 V, R _L = 125Ω	
		Maximum	0.75 ms	0.5 ms			
	Turn off time*2	Typical	0.08 ms		0.02 ms		
		Maximum	0.2 ms				
	I/O capacitance	Typical	0.8 pF				f = 1 MHz, V _B = 0 V
		Maximum	1.5 pF				
Initial I/O isolation resistance	Minimum	1,000 MΩ			500 V DC		

Note: Variation possible through combinations of output capacitance and on resistance. For more information, please contact our sales office in your area.

*Turn on/Turn off time

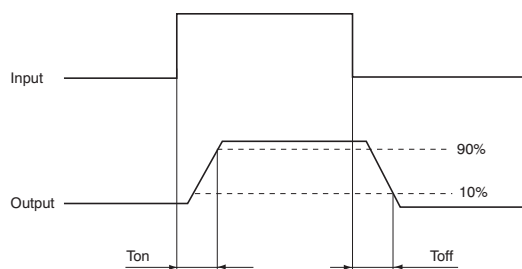

RECOMMENDED OPERATING CONDITIONS

Please obey the following conditions to ensure proper relay operation and resetting.

Item	Symbol	Recommended value	Unit
Input LED current	I _F	5	mA

■ For Dimensions, see Page 62.

■ For Schematic and Wiring Diagrams, see Page 64.

■ For Cautions for Use, see Page 71.

■ These products are not designed for automotive use.

If you are considering to use these products for automotive applications, please contact your local Panasonic technical representative.

For more information, see page 80.

RF SSOP 1 Form A CxR10 (AQY221○○V)

REFERENCE DATA

20. Load current vs. ambient temperature characteristics

Allowable ambient temperature: -40°C to $+85^{\circ}\text{C}$
 -40°F to $+185^{\circ}\text{F}$

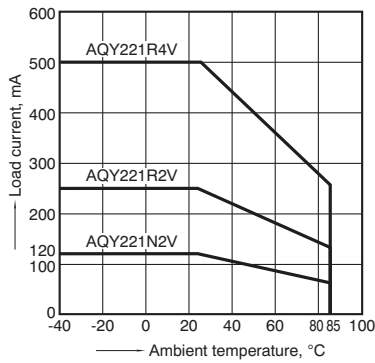

21. Load current vs. Load voltage characteristics

Ambient temperature: 25°C 77°F

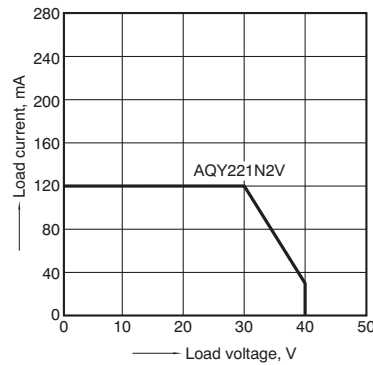

22. On resistance vs. ambient temperature characteristics

Measured portion: between terminals 3 and 4
 LED current: 5 mA; Load voltage: 10V (DC)
 Continuous load current: AQY221R4V 500mA (DC),
 AQY221R2V 250mA (DC), AQY221N2V 80mA (DC)

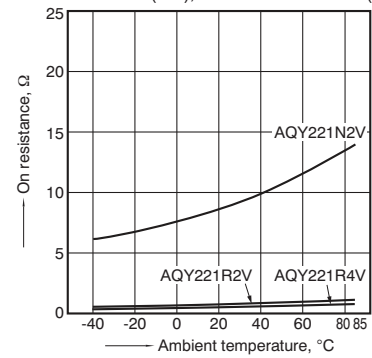

23. Turn on time vs. ambient temperature characteristics

Measured portion: between terminals 3 and 4
 LED current: 5 mA; Load voltage: 10V (DC)
 Continuous load current: AQY221R4V 500mA (DC),
 AQY221R2V 250mA (DC), AQY221N2V 80mA (DC)

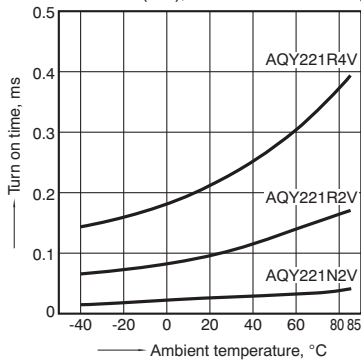

24. Turn off time vs. ambient temperature characteristics

Measured portion: between terminals 3 and 4
 LED current: 5 mA; Load voltage: 10V (DC)
 Continuous load current: AQY221R4V 500mA (DC),
 AQY221R2V 250mA (DC), AQY221N2V 80mA (DC)

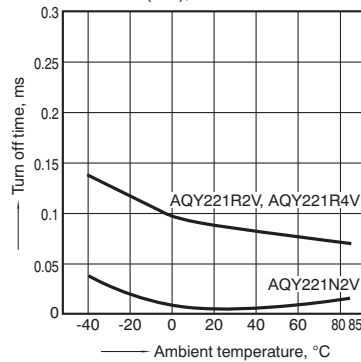

25. LED operate current vs. ambient temperature characteristics

Measured portion: between terminals 3 and 4
 Load voltage: 10V (DC)
 Continuous load current: AQY221R4V 500mA (DC),
 AQY221R2V 250mA (DC), AQY221N2V 80mA (DC)

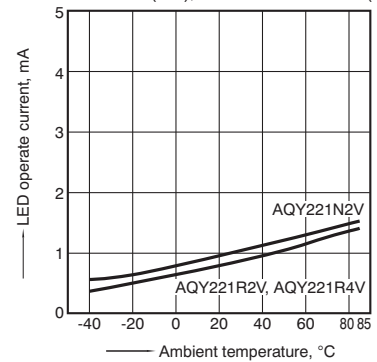

26. LED turn off current vs. ambient temperature characteristics

Measured portion: between terminals 3 and 4
 Load voltage: 10V (DC)
 Continuous load current: AQY221R4V 500mA (DC),
 AQY221R2V 250mA (DC), AQY221N2V 80mA (DC)

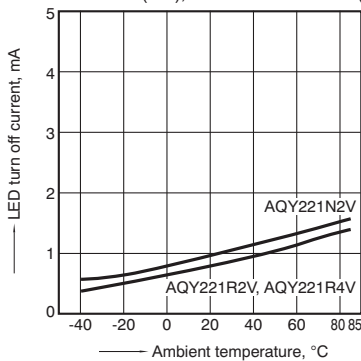

27. LED dropout voltage vs. ambient temperature characteristics

LED current: 5 to 50 mA

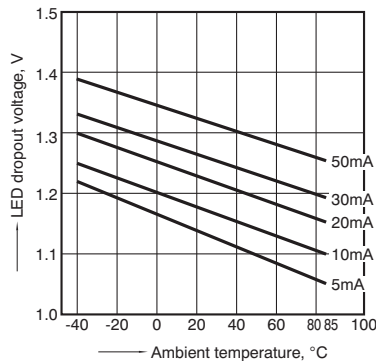

28. Current vs. voltage characteristics of output at MOS portion

Measured portion: between terminals 3 and 4
 Ambient temperature: 25°C 77°F

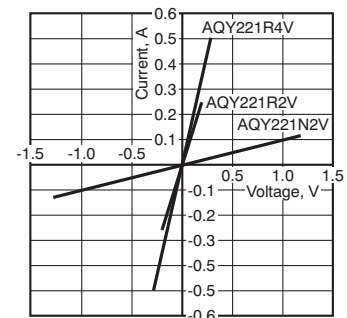

RF SSOP 1 Form A CxR10 (AQY221○○V)

29. Off state leakage current vs. load voltage characteristics

Measured portion: between terminals 3 and 4
Ambient temperature: 25°C 77°F

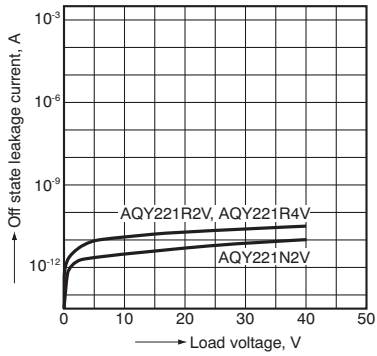

30. Turn on time vs. LED forward current characteristics

Measured portion: between terminals 3 and 4
Load voltage: 10V (DC)
Continuous load current: AQY221R4V 500mA (DC),
AQY221R2V 250mA (DC), AQY221N2V 80mA (DC)
Ambient temperature: 25°C 77°F

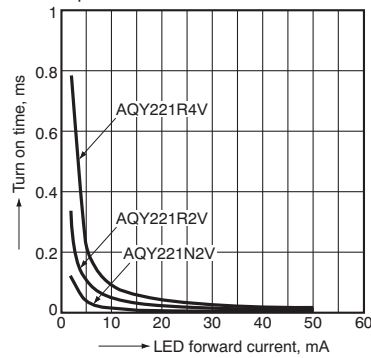

31. Turn off time vs. LED forward current characteristics

Measured portion: between terminals 3 and 4
Load voltage: 10V (DC)
Continuous load current: AQY221R4V 500mA (DC),
AQY221R2V 250mA (DC), AQY221N2V 80mA (DC)
Ambient temperature: 25°C 77°F

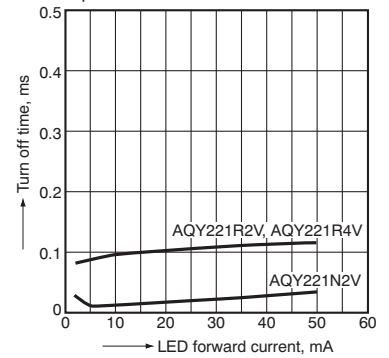

32. Output capacitance vs. applied voltage characteristics

Measured portion: between terminals 3 and 4
Frequency: 1 MHz, 30m Vrms
Ambient temperature: 25°C 77°F

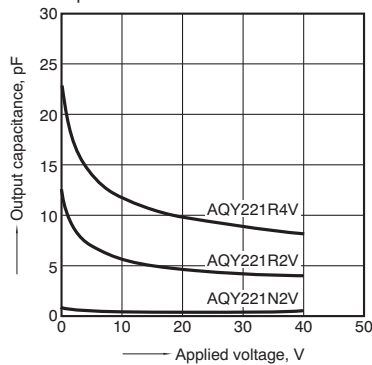

33. Isolation vs. frequency characteristics (50Ω impedance)

Measured portion: between terminals 3 and 4
Ambient temperature: 25°C 77°F

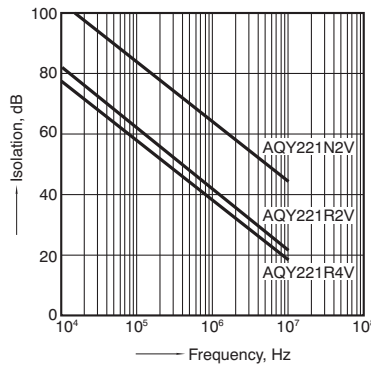

34. Insertion loss vs. frequency characteristics (50Ω impedance)

Measured portion: between terminals 3 and 4
Ambient temperature: 25°C 77°F

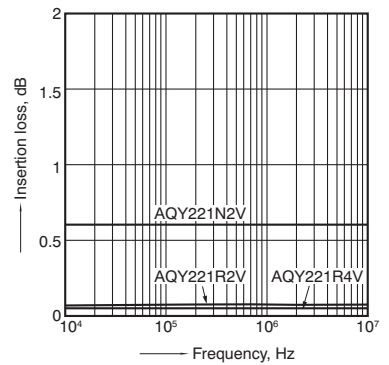

Panasonic

ideas for life

Space-saving
SSOP 1 Form A type
with built-in resistor
40V load voltage

PhotoMOS®
RF SSOP C×R10
Voltage-sensitive (AQY221F○2V)



CAD Data

mm inch

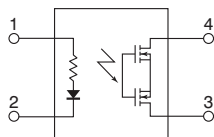

FEATURES

1. Built-in input resistor means less man-hours when mounting

The voltage-sensitive type, which eliminates the need to mount an external input resistor, is now available in a small package. Man-hours spent mounting external input resistors are cut and board designing is simplified.

2. Save space on PC board

Since the small package size remains the same while including a built-in input resistor, space on the PC board is saved. This makes it easier to incorporate space savings when designing miniature devices.

3. Both low on-resistance (R type) and low capacitance (C type) available at excellent electrical characteristics of C×R10

- R type: On resistance 0.75Ω (typ.)
Output resistance 12.5pF (typ.)
- C type: On resistance 9.5Ω (typ.)
Output capacitance 1pF (typ.)

TYPICAL APPLICATIONS

1. Measuring and testing equipment

Semiconductor testing equipment, Probe cards, Datalogger, Board tester and other testing equipment.

2. Telecommunication and broadcasting equipment

3. Medical equipment

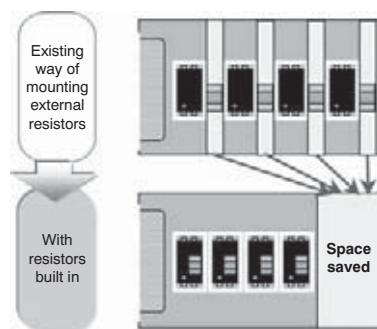

<Artistic impression of PC board space savings due to built-in resistor>

TYPES

	Type	Output rating*1		Package	Part No.*2		Packing quantity in tape and reel
		Load voltage	Load current		Tape and reel packing style (Picked from the 1 and 4-pin side)	Tape and reel packing style (Picked from the 2 and 3-pin side)	
AC/DC dual use	Low on-resistance (R type)	40 V	0.25A	SSOP	AQY221FR2VY	AQY221FR2VW	3,500 pcs.
	Low capacitance (C type)	40 V	0.12A		AQY221FN2VY	AQY221FN2VW	

Notes: *1 Indicate the peak AC and DC values.

*2 Tape and reel is the standard packing style for SSOP.

For space reasons, the three initial letters of the part number "AQY", and the package (SSOP) indicator "V" and the packing style indicator "Y" or "W" are not marked on the relay. (Ex. the label for product number AQY221FR2VY is 221FR2)

RATING

1. Absolute maximum ratings (Condition: ambient temperature 25°C 77°F)

Item		Symbol	AQY221FR2V	AQY221FN2V	Remarks
Input	Input voltage	V _{IN}	6V		
	Input reverse voltage	V _{RIN}	5V		
	Power dissipation	P _{in}	65mW		
Output	Load voltage (peak AC)	V _L	40V		
	Load current	I _L	0.25A	0.12A	Peak AC, DC
	Peak load current	I _{peak}	0.75A	0.2A	100ms (1shot), V _L =DC
	Power dissipation	P _{out}	250mW		
Total power dissipation		P _T	300mW		
I/O isolation voltage		V _{iso}	500V AC		
Operating temperature		T _{opr}	-40°C to +85°C -40°F to +185°F		Non-condensing at low temperatures
Storage temperature		T _{stg}	-40°C to +100°C -40°F to +212°F		

RF SSOP CxR10 Voltage-sensitive (AQY221F○2V)

2. Electrical characteristics (Condition: ambient temperature 25°C 77°F)

Item		Symbol	AQY221FR2V	AQY221FN2V	Condition
Input	Operate voltage	Typ.	1.3V		AQY221FR2V: I _L = Max. AQY221FN2V: I _L = 80mA
		Max.	4V		
	Turn off voltage	Min.	0.8V		
		Typ.	1.3V		
Input current	Typ.	8.5mA		V _{IN} = 5V	
Output	On resistance	Typ.	0.75Ω	9.5Ω	AQY221FR2V: V _{IN} = 5V, I _L = Max. AQY221FN2V: V _{IN} = 5V, I _L = 80mA Within 1 s on time
		Max.	1.25Ω	12.5Ω	
	Output capacitance	Typ.	12.5pF	1pF	V _{IN} = 0V, V _B = 0V, f = 1MHz
		Max.	18pF	1.5pF	
Off state leakage current	Typ.	0.02nA	0.01nA	V _{IN} = 0V, V _L = Max.	
	Max.	10nA			
Transfer characteristics	Turn on time*	Typ.	0.05ms	0.01ms	AQY221FR2V: V _{IN} = 5V, V _L = 10V, R _L = 40% AQY221FN2V: V _{IN} = 5V, V _L = 10V, R _L = 125%
		Max.	0.5ms		
	Turn off time*	Typ.	0.06ms	0.03ms	V _{IN} = 5V, V _L = 10V, R _L = 125%
		Max.	0.2ms		
	I/O capacitance	Typ.	0.8pF		f = 1MHz, V _B = 0V
		Max.	1.5pF		f = 1MHz, V _B = 0V
Initial I/O isolation resistance	Min.	R _{iso}	1,000MΩ		500V DC

Note: If you wish to change the input voltage, rating or performance, please inquire with our sales.

*Turn on/Turn off time

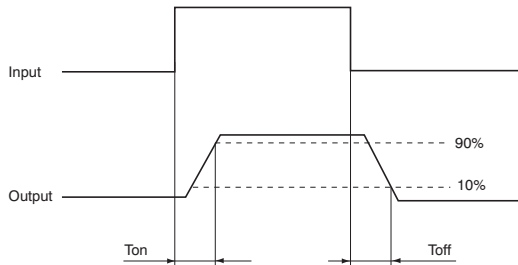

RECOMMENDED OPERATING CONDITIONS

Please obey the following conditions to ensure proper relay operation and resetting.

Item	Symbol	Minimum	Typical	Maximum	Unit
Input voltage	V _{IN}	4.5	5	5.5	V

■ For Dimensions, see Page 62.

■ For Schematic and Wiring Diagrams, see Page 64.

■ For Cautions for Use, see Page 71.

■ These products are not designed for automotive use.

If you are considering to use these products for automotive applications, please contact your local Panasonic technical representative.

For more information, see page 80.

RF SSOP CxR10 Voltage-sensitive (AQY221F○2V)

REFERENCE DATA

35. Load current vs. ambient temperature characteristics

Allowable ambient temperature: -40°C to $+85^{\circ}\text{C}$
 -40°F to $+185^{\circ}\text{F}$

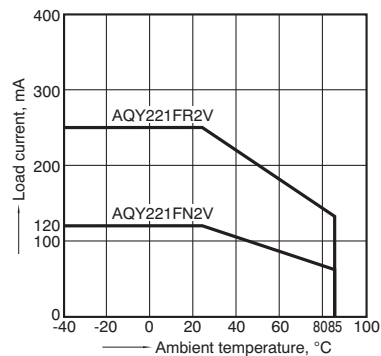

36. Load current vs. Load voltage characteristics

Ambient temperature: 25°C 77°F

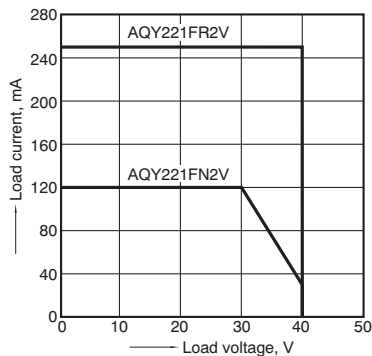

37. On resistance vs. ambient temperature characteristics

Measured portion: between terminals 3 and 4
 Input voltage: 5V; Load voltage: 10V (DC);
 Continuous load current: 80mA (DC)

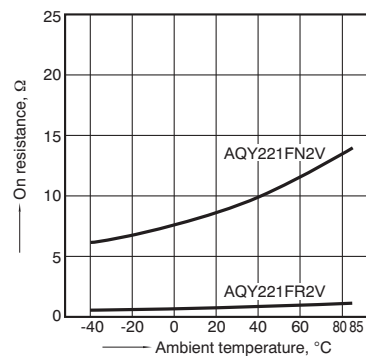

38. Turn on time vs. ambient temperature characteristics

Input voltage: 5V; Load voltage: 10V (DC);
 Continuous load current: 250mA (DC) R type,
 80mA (DC) C type

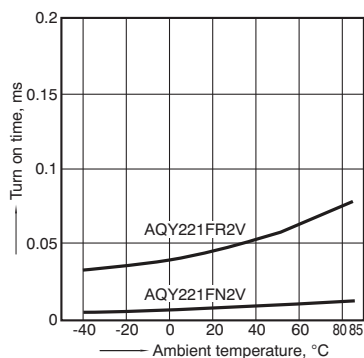

39. Turn off time vs. ambient temperature characteristics

Input voltage: 5V; Load voltage: 10V (DC);
 Continuous load current: 250mA (DC) R type,
 80mA (DC) C type

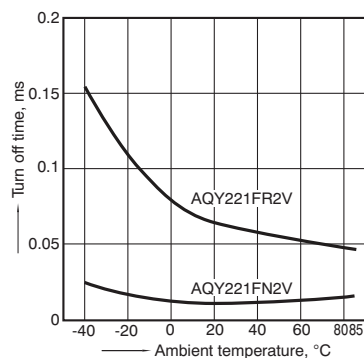

40. Turn on voltage vs. ambient temperature characteristics

Load voltage: 10V (DC);
 Continuous load current: 250mA (DC) R type,
 80mA (DC) C type

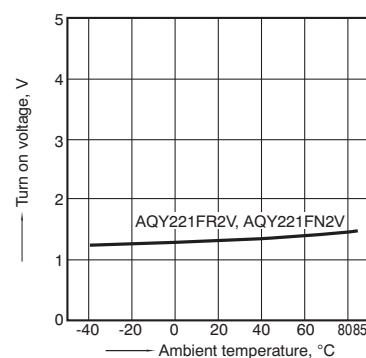

41. Turn off voltage vs. ambient temperature characteristics

Load voltage: 10V (DC);
 Continuous load current: 250mA (DC) R type,
 80mA (DC) C type

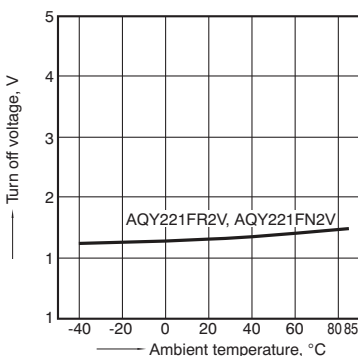

42. Input current vs. ambient temperature characteristics

Input voltage: 5V

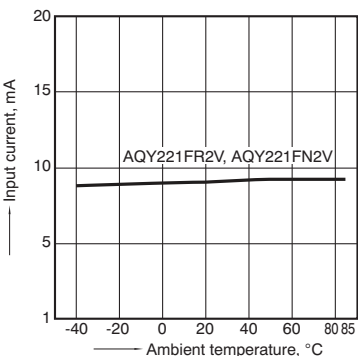

43. Current vs. voltage characteristics of output at MOS portion

Measured portion: between terminals 3 and 4
 Ambient temperature: 25°C 77°F

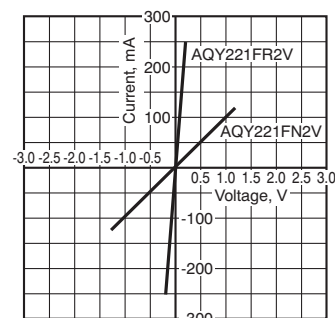

RF SSOP CxR10 Voltage-sensitive (AQY221F○2V)

44. Input current vs. input voltage characteristics

Ambient temperature: 25°C 77°F
(Recommended input voltage: 5±0.5V)

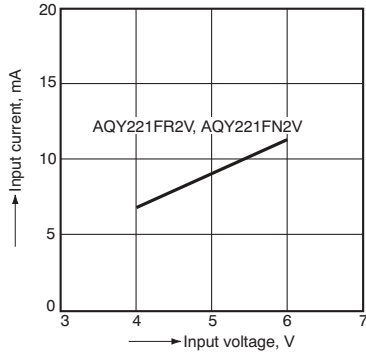

45. Off state leakage current vs. load voltage characteristics

Measured portion: between terminals 3 and 4
Ambient temperature: 25°C 77°F

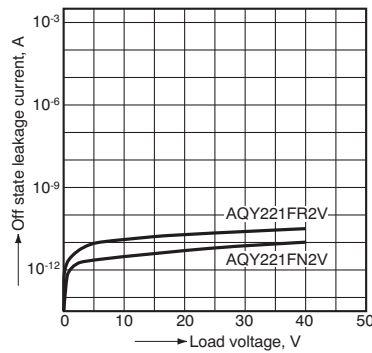

46. Turn on time vs. input voltage characteristics

Measured portion: between terminals 3 and 4
Load voltage: 10V (DC);
Continuous load current: 250mA (DC) R type,
80mA (DC) C type; Ambient temperature: 25°C 77°F

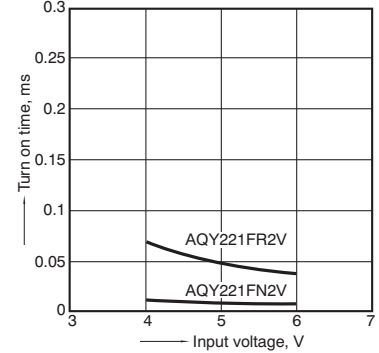

47. Turn off time vs. input voltage characteristics

Measured portion: between terminals 3 and 4
Load voltage: 10V (DC);
Continuous load current: 250mA (DC) R type,
80mA (DC) C type; Ambient temperature: 25°C 77°F

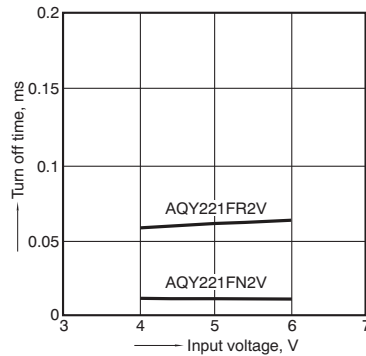

48. Output capacitance vs. applied voltage characteristics

Measured portion: between terminals 3 and 4
Frequency: 1 MHz, 30m Vrms;
Ambient temperature: 25°C 77°F

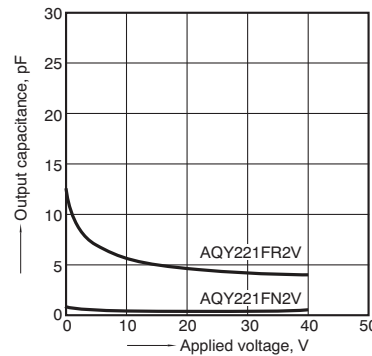

49. Isolation vs. frequency characteristics (50Ω impedance)

Measured portion: between terminals 3 and 4
Ambient temperature: 25°C 77°F

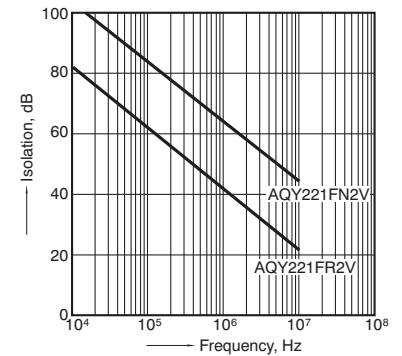

50. Insertion loss vs. frequency characteristics (50Ω impedance)

Measured portion: between terminals 3 and 4
Ambient temperature: 25°C 77°F

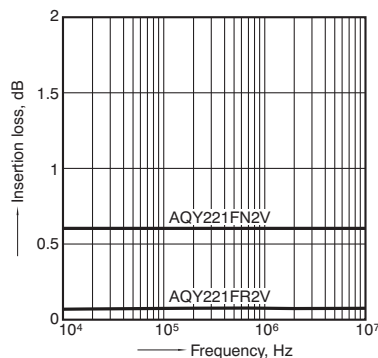

Panasonic

ideas for life

Miniature SOP4-pin
with C×R10
40V load voltage

PhotoMOS[®]
RF SOP 1 Form A C×R10
(AQY221○2S)

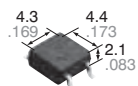

<R type>

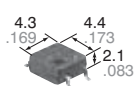

<C type>

CAD Data

mm inch

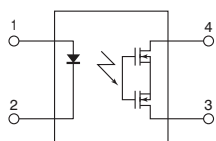

FEATURES

1. Both low on-resistance (R type) and low capacitance (C type) available at excellent characteristics of C×R10

	AQY221R2S (R type)	AQY221N2S (C type)
Low on resistance: R	0.8Ω	9.5Ω
Low output capacitance: C	13pF	1pF

2. High speed switching

Turn on time: 0.03ms (typ.)

Turn off time: 0.03ms (typ.)

(AQY221N2S)

3. Small profile of miniature SOP4-pin
4. Low-level off state leakage current of typ. 0.01nA (AQY221N2S)

TYPICAL APPLICATIONS

1. Measuring and testing equipment

IC tester, Liquid crystal driver tester, Semiconductor performance tester, Bare board tester, In-circuit tester, Function tester, etc.

2. Telecommunication and broadcasting equipment

3. Medical equipment

Ultrasonic wave diagnostic machine

4. Multi-point recorder

Warping, Thermo couple, etc.

TYPES

	Type	Output rating*		Package	Part No.			Packing quantity	
		Load voltage	Load current		Tube packing style	Tape and reel packing style		Tube	Tape and reel
						Picked from the 1/2-pin side	Picked from the 3/4-pin side		
AC/DC dual use	Low on resistance (R type)	40V	250mA	SOP4-pin	AQY221R2S	AQY221R2SX	AQY221R2SZ	1 tube contains: 100 pcs. 1 batch contains: 2,000 pcs.	1,000 pcs.
	Low capacitance (C type)	40V	120mA		AQY221N2S	AQY221N2SX	AQY221N2SZ		

* Indicate the peak AC and DC values.

Note: For space reasons, the initial letters of the part number "AQY", the package (SOP) indicator "S" and the packing style indicator "X" or "Z" are not marked on the relay.
(Ex. the label for product number AQY221R2SX is 221R2)

RATING

1. Absolute maximum ratings (Ambient temperature: 25°C 77°F)

Item		Symbol	AQY221R2S (R type)	AQY221N2S (C type)	Remarks
Input	LED forward current	I _F	50mA		
	LED reverse voltage	V _R	5V		
	Peak forward current	I _{FP}	1A		f=100 Hz, Duty factor=0.1%
	Power dissipation	P _{in}	75mW		
Output	Load voltage (peak AC)	V _L	40V		
	Continuous load current	I _L	0.25A	0.12A	Peak AC, DC
	Peak load current	I _{peak}	0.75A	0.30A	100 ms (1 shot), V _L = DC
	Power dissipation	P _{out}	300mW		
Total power dissipation		P _T	350mW		
I/O isolation voltage		V _{iso}	500V AC	1,500V AC	
Temperature limits	Operating	T _{opr}	-40°C to +85°C -40°F to +185°F		Non-condensing at low temperatures
	Storage	T _{stg}	-40°C to +100°C -40°F to +212°F		

RF SOP 1 Form A CxR10 (AQY221○2S)

2. Electrical characteristics (Ambient temperature: 25°C 77°F)

Item		Symbol	AQY221R2S (R type)	AQY221N2S (C type)	Condition
Input	LED operate current	Typical	0.5 mA	0.9 mA	$I_L = 250 \text{ mA}$ (R type) $I_L = 80 \text{ mA}$ (C type)
		Maximum	3.0 mA		
	LED turn off current	Minimum	0.1 mA	0.2 mA	$I_L = 250 \text{ mA}$ (R type) $I_L = 80 \text{ mA}$ (C type)
		Typical	0.4 mA	0.85 mA	
LED dropout voltage	Typical	1.25 V (1.14 V at $I_F = 5 \text{ mA}$)		$I_F = 50 \text{ mA}$	
	Maximum	1.5 V			
Output	On resistance	Typical	0.8Ω	9.5Ω	$I_F = 5 \text{ mA}$ $I_L = 250 \text{ mA}$ (R type), $I_L = 80 \text{ mA}$ (C type) Within 1 s on time
		Maximum	1.25Ω	12.5Ω	
	Output capacitance	Typical	13 pF	1.0 pF	$I_F = 0 \text{ mA}$ $V_B = 0 \text{ V}$ $f = 1 \text{ MHz}$
		Maximum	18 pF	1.5 pF	
Off state leakage current	Typical	0.03 nA	0.01 nA	$I_F = 0 \text{ mA}$ $V_L = \text{Max.}$	
	Maximum	10 nA			
Transfer characteristics	Turn on time*	Typical	0.1 ms	0.03 ms	$I_F = 5 \text{ mA}$ $V_L = 10 \text{ V}$ $R_L = 40\Omega$ (R type), 125Ω (C type)
		Maximum	0.5ms		
	Turn off time*	Typical	0.06 ms	0.03 ms	$I_F = 5 \text{ mA}$ $V_L = 10 \text{ V}$ $R_L = 40\Omega$ (R type), 125Ω (C type)
		Maximum	0.2 ms		
	I/O capacitance	Typical	0.8 pF		$f = 1 \text{ MHz}$ $V_B = 0 \text{ V}$
		Maximum	1.5 pF		
Initial I/O isolation resistance	Minimum	R_{iso}	1,000MΩ		500 V DC

*Turn on/Turn off time

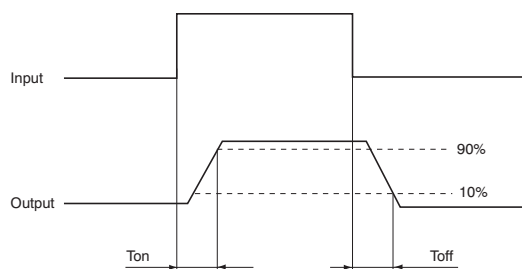

RECOMMENDED OPERATING CONDITIONS

Please obey the following conditions to ensure proper relay operation and resetting.

Item	Symbol	Recommended value	Unit
Input LED current	I_F	5	mA

■ For Dimensions, see page 62.

■ For Schematic and Wiring Diagrams, see page 64.

■ For Cautions for Use, see page 71.

■ These products are not designed for automotive use.

If you are considering to use these products for automotive applications, please contact your local Panasonic technical representative.

For more information, see page 80.

RF SOP 1 Form A CxR10 (AQY221○2S)

REFERENCE DATA

1. Load current vs. ambient temperature characteristics

Allowable ambient temperature: -40°C to +85°C
-40°F to +185°F

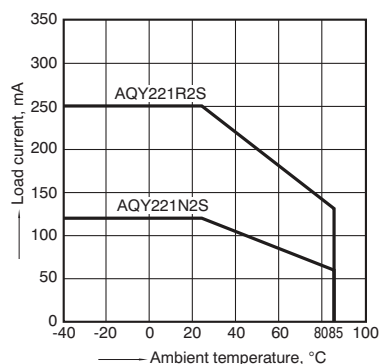

2. Load current vs. Load voltage characteristics

Ambient temperature: 25°C 77°F

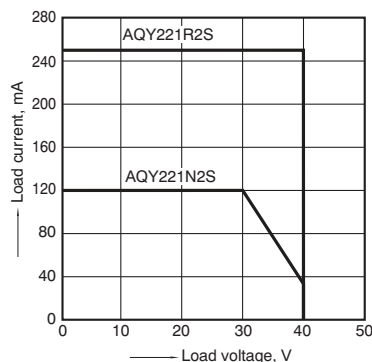

3. On resistance vs. ambient temperature characteristics

Measured portion: between terminals 3 and 4
LED current: 5 mA; Load voltage: Max. (DC);
Load current: 250mA (DC) [R type], 80mA (DC) [C type]

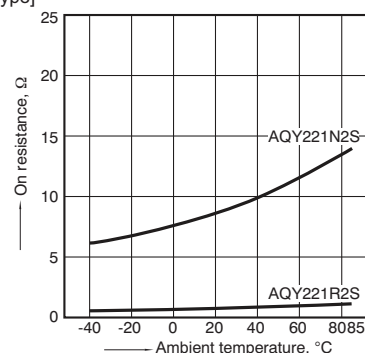

4. Turn on time vs. ambient temperature characteristics

Measured portion: between terminals 3 and 4
LED current: 5 mA; Load voltage: 10V (DC);
Continuous load current: 250mA (DC) [R type],
80mA (DC) [C type]

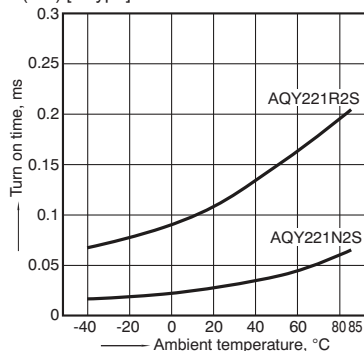

5. Turn off time vs. ambient temperature characteristics

LED current: 5 mA; Load voltage: 10V (DC);
Continuous load current: 250mA (DC) [R type],
80mA (DC) [C type]

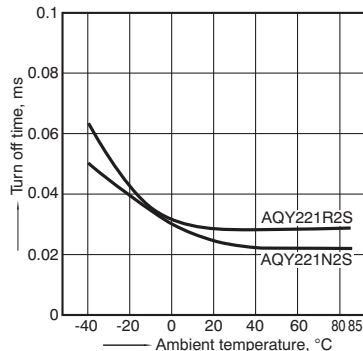

6. LED operate current vs. ambient temperature characteristics

Load voltage: Max. (DC);
Continuous load current: 250mA (DC) [R type],
80mA (DC) [C type]

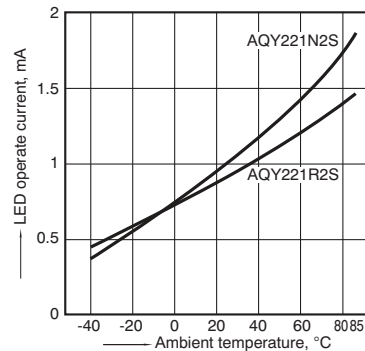

7. LED turn off current vs. ambient temperature characteristics

Load voltage: Max. (DC); Continuous load current:
250mA (DC) [R type], 80mA (DC) [C type];

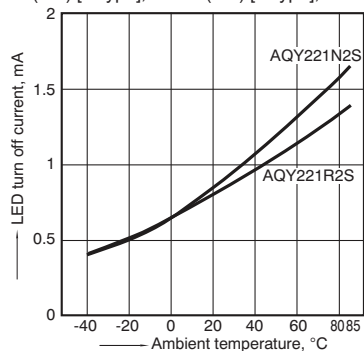

8. LED dropout voltage vs. ambient temperature characteristics

LED current: 5 to 50 mA

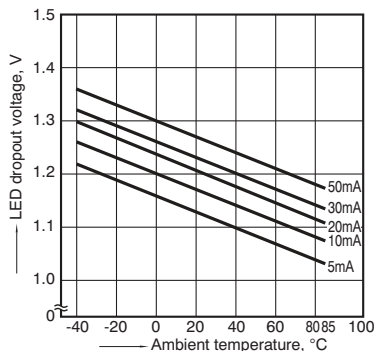

9. Current vs. voltage characteristics of output at MOS portion

Measured portion: between terminals 3 and 4
Ambient temperature: 25°C 77°F

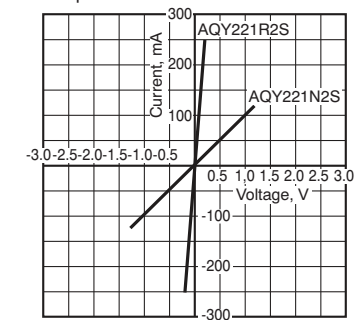

RF SOP 1 Form A CxR10 (AQY221○2S)

10. Off state leakage current vs. load voltage characteristics

Measured portion: between terminals 3 and 4
Ambient temperature: 25°C 77°F

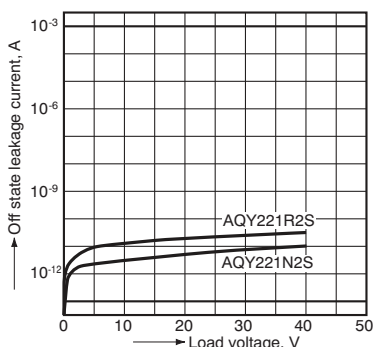

11. Turn on time vs. LED forward current characteristics

Measured portion: between terminals 3 and 4
Load voltage: 10V (DC); Continuous load current: 250mA (DC) [R type], 80mA (DC) [C type];
Ambient temperature: 25°C 77°F

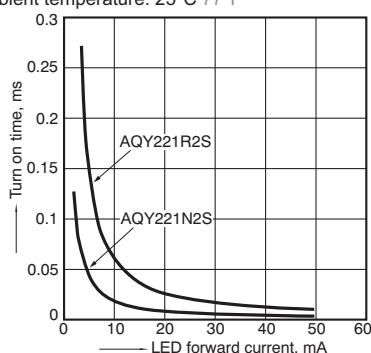

12. Turn off time vs. LED forward current characteristics

Measured portion: between terminals 3 and 4
Load voltage: 10V (DC); Continuous load current: 250mA (DC) [R type], 80mA (DC) [C type];
Ambient temperature: 25°C 77°F

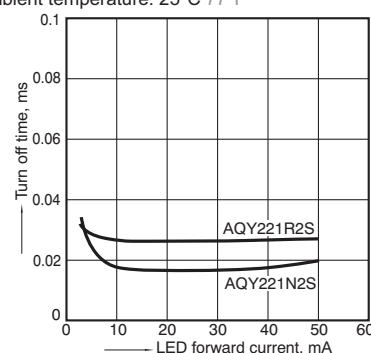

PhotoMOS

13. Output capacitance vs. applied voltage characteristics

Measured portion: between terminals 3 and 4
Frequency: 1 MHz, 30m Vrms; Ambient temperature: 25°C 77°F

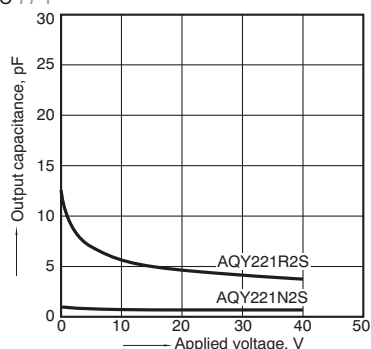

14. Isolation vs. frequency characteristics (50Ω impedance)

Measured portion: between terminals 3 and 4
Ambient temperature: 25°C 77°F

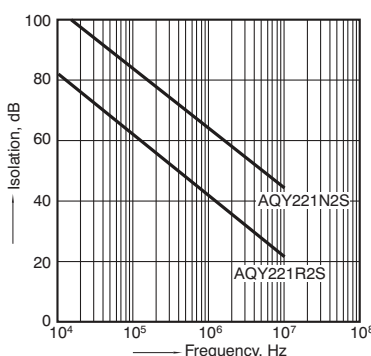

15. Insertion loss vs. frequency characteristics (50Ω impedance)

Measured portion: between terminals 3 and 4
Ambient temperature: 25°C 77°F

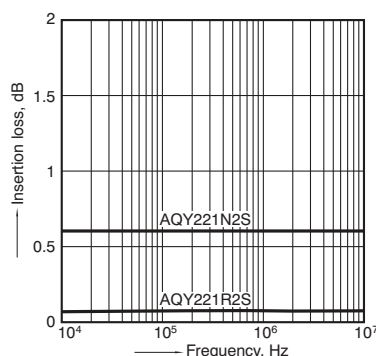

16-(1). On resistance distribution (R type)

Measured portion: between terminals 3 and 4
Continuous load current: 250mA (DC)
Ambient temperature: 25°C 77°F

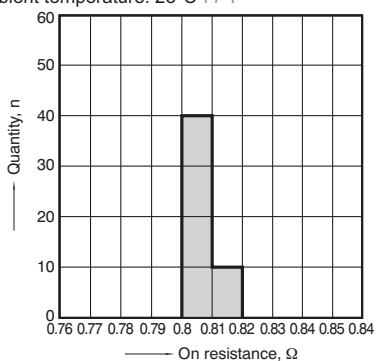

16-(2). On resistance distribution (C type)

Measured portion: between terminals 3 and 4
Continuous load current: 80mA (DC)
Ambient temperature: 25°C 77°F

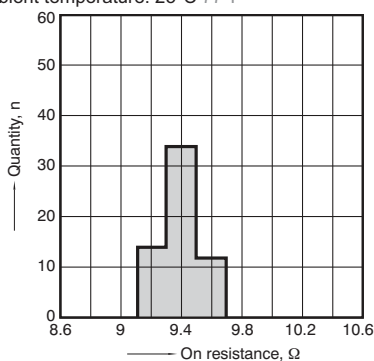

17-(1). Turn on time distribution (R type)

Load voltage: 10V (DC)
Continuous load current: 250mA (DC)
Ambient temperature: 25°C 77°F

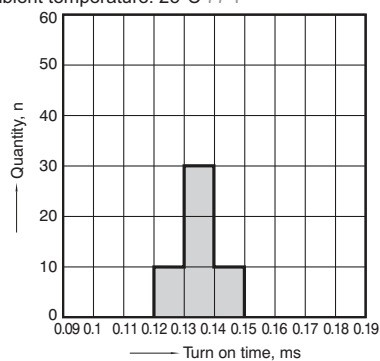

RF SOP 1 Form A CxR10 (AQY221○2S)

17-(2). Turn on time distribution (C type)

Load voltage: 10V (DC)
 Continuous load current: 80mA (DC)
 Ambient temperature: 25°C 77°F

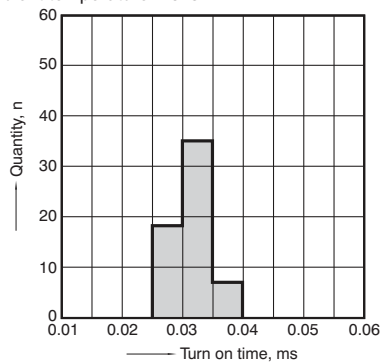

18-(1). Turn off time distribution (R type)

Load voltage: 10V (DC)
 Continuous load current: 250mA (DC)
 Ambient temperature: 25°C 77°F

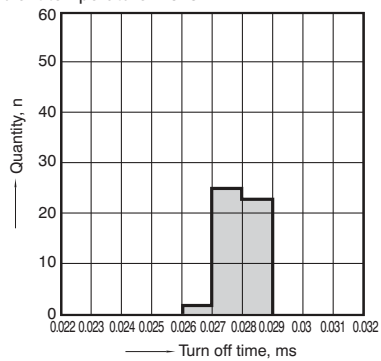

18-(2). Turn off time distribution (C type)

Load voltage: 10V (DC)
 Continuous load current: 80mA (DC)
 Ambient temperature: 25°C 77°F

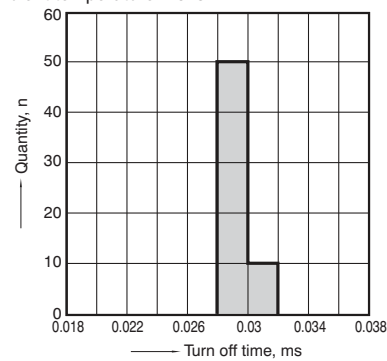

19-(1). LED operate current distribution (R type)

Load voltage: 10V (DC)
 Continuous load current: 250mA (DC)
 Ambient temperature: 25°C 77°F

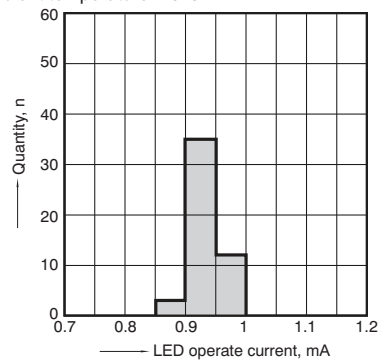

19-(2). LED operate current distribution (C type)

Load voltage: 10V (DC)
 Continuous load current: 80mA (DC)
 Ambient temperature: 25°C 77°F

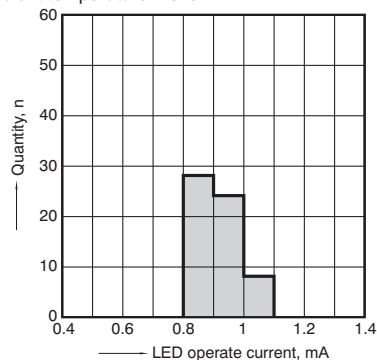

Panasonic

ideas for life

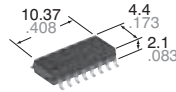

CAD Data

mm inch

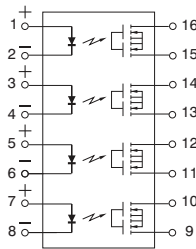

Space-saving low C×R type with 4 channels in a SOP16-pin package

PhotoMOS® RF SOP 4 Form A C×R10 (AQS221○2S)

FEATURES

1. 4-channel (4 Form A) in a small SOP16-pin package

The device comes in a miniature SOP measuring (W)10.37 × (L)4.4 × (H)2.1mm (W).408×(L).173×(H).083inch

This contributes to space-saving of PC board.

2. Both low on-resistance (R type) and low capacitance (C type) available at excellent characteristics of C×R10

- R type: On resistance 0.8Ω (typ.)
Output capacitance 13pF (typ.)
- C type: On resistance 9.7Ω (typ.)
Output capacitance 1.0pF (typ.)

3. High-speed switching of 0.03ms (C type, typical turn on time)

4. Applicable for 4 Form A use, as well as 4 independent 1 Form A

TYPICAL APPLICATIONS

1. Measuring and testing equipment

IC tester, Liquid crystal driver tester, Semiconductor performance tester, Bare board tester, In-circuit tester, Function tester, etc.

2. Telecommunication and broadcasting equipment

3. Medical equipment

Ultrasonic wave diagnostic machine

4. Multi-point recorder

Warping, Thermo couple, etc.

TYPES

	Type	Output rating*1		Package	Part No.*2			Packing quantity	
		Load voltage	Load current		Tube packing style	Tape and reel packing style		Tube	Tape and reel
						Picked from the 1/2/3/4/5/6/7/8-pin side	Picked from the 9/10/11/12/13/14/15/16-pin side		
AC/DC dual use	Low on-resistance (R type)	40V	0.16A	SOP16-pin	AQS221R2S	AQS221R2SX	AQS221R2SZ	1 tube contains: 50 pcs. 1 batch contains: 1,000 pcs.	1,000 pcs.
	Low capacitance (C type)	40V	0.06A		AQS221N2S	AQS221N2SX	AQS221N2SZ		

Notes:

*1 Indicate the peak AC and DC values.

*2 The packing style indicator "X" or "Z" is not marked on the relay.

RATING

1. Absolute maximum ratings (Ambient temperature: 25°C 77°F)

Item		Symbol	AQS221R2S (R type)	AQS221N2S (C type)	Remarks
Input	LED forward current	I _F	50 mA		
	LED reverse voltage	V _R	5 V		
	Peak forward current	I _{FP}	1 A		f = 100 Hz, Duty factor = 0.1%
	Power dissipation	P _{in}	75 mW		
Output	Load voltage (peak AC)	V _L	40 V		
	Continuous load current	I _L	0.16 A	0.06 A	Peak AC, DC
	Peak load current	I _{peak}	0.2 A	0.12 A	100 ms (1 shot), V _L = DC
	Power dissipation	P _{out}	600 mW		
Total power dissipation		P _T	650 mW		
I/O isolation voltage		V _{iso}	500 V AC		
Temperature limits	Operating	T _{opr}	-40°C to +85°C -40°F to +185°F		Non-condensing at low temperatures
	Storage	T _{stg}	-40°C to +100°C -40°F to +212°F		

RF SOP 4 Form A C×R10 (AQS221○2S)

2. Electrical characteristics (Ambient temperature: 25°C 77°F)

Item		Symbol	AQS221R2S (R type)	AQS221N2S (C type)	Condition
Input	LED operate current	Typical	0.5 mA	0.9 mA	$I_L = \text{Max.}$
		Maximum	3.0 mA		
	LED turn off current	Minimum	0.1 mA		$I_L = \text{Max.}$
		Typical	0.4 mA	0.85 mA	
LED dropout voltage	Typical	1.25 V (1.14 V at $I_F = 5 \text{ mA}$)		$I_F = 50 \text{ mA}$	
	Maximum	1.5 V			
Output	On resistance	Typical	0.8Ω	9.5Ω	$I_F = 5 \text{ mA}$ $I_L = \text{Max.}$ Within 1 s on time
		Maximum	1.25Ω	12.5Ω	
	Output capacitance	Typical	13.0 pF	1.0 pF	$I_F = 0 \text{ mA}$ $V_B = 0 \text{ V}$ $f = 1 \text{ MHz}$
		Maximum	18.0 pF	1.5 pF	
	Off state leakage current	Typical	0.03 nA	0.01 nA	$I_F = 0 \text{ mA}$ $V_L = \text{Max.}$
		Maximum	10 nA		
Transfer characteristics	Turn on time*	Typical	0.1 ms	0.03 ms	$I_F = 5 \text{ mA}$ $V_L = 10 \text{ V}$ $R_L = 62.5\Omega$ (R type), $R_L = 500\Omega$ (C type)
		Maximum	0.5 ms	0.2 ms	
	Turn off time*	Typical	0.06 ms	0.03 ms	$I_F = 5 \text{ mA}$ $V_L = 10 \text{ V}$ $R_L = 62.5\Omega$ (R type), $R_L = 500\Omega$ (C type)
		Maximum	0.2 ms		
	I/O capacitance	Typical	0.8 pF		$f = 1 \text{ MHz}$ $V_B = 0 \text{ V}$
		Maximum	1.5 pF		
Initial I/O isolation resistance	Minimum	R_{iso}	1,000 MΩ	500 V DC	

*Turn on/Turn off time

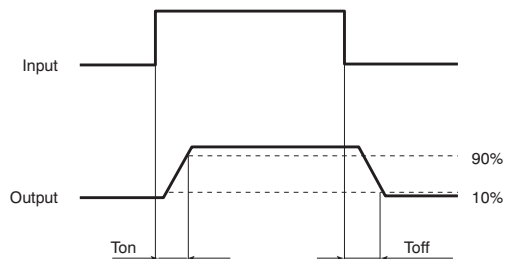

RECOMMENDED OPERATING CONDITIONS

Please obey the following conditions to ensure proper relay operation and resetting.

Item	Symbol	Recommended value	Unit
Input LED current	I_F	5	mA

■ For Dimensions, see page 62.

■ For Schematic and Wiring Diagrams, see page 67.

■ For Cautions for Use, see page 71.

■ These products are not designed for automotive use.

If you are considering to use these products for automotive applications, please contact your local Panasonic technical representative.

For more information, see page 80.

RF SOP 4 Form A C×R10 (AQS221○2S)

REFERENCE DATA

1. Load current vs. ambient temperature characteristics

Allowable ambient temperature: -40°C to $+85^{\circ}\text{C}$
 -40°F to $+185^{\circ}\text{F}$

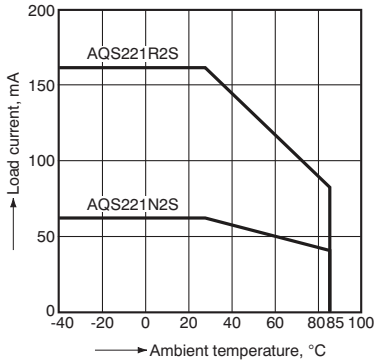

2. Load current vs. load voltage characteristics

Ambient temperature: 25°C 47°F

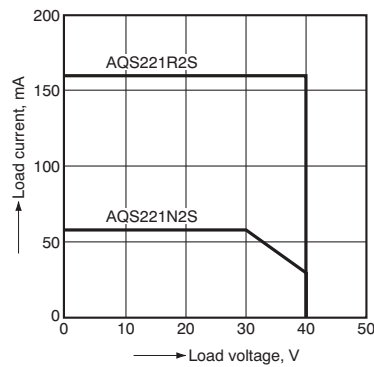

3. On resistance vs. ambient temperature characteristics

LED current: 5 mA; Load voltage: 10 V (DC);
 Continuous load current: 160 mA (DC) R type/
 60 mA (DC) C type

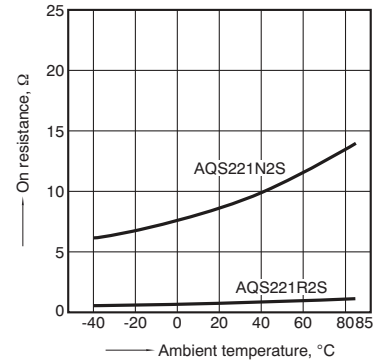

4. Turn on time vs. ambient temperature characteristics

LED current: 5 mA; Load voltage: 10 V (DC);
 Continuous load current: 160 mA (DC) R type/
 20 mA (DC) C type

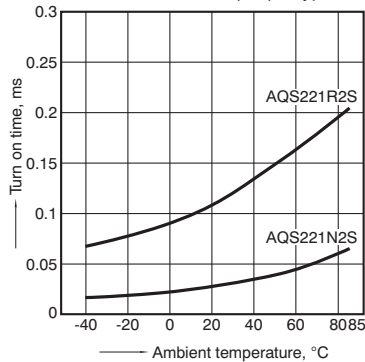

5. Turn off time vs. ambient temperature characteristics

LED current: 5 mA; Load voltage: 10 V (DC);
 Continuous load current: 160 mA (DC) R type/
 20 mA (DC) C type

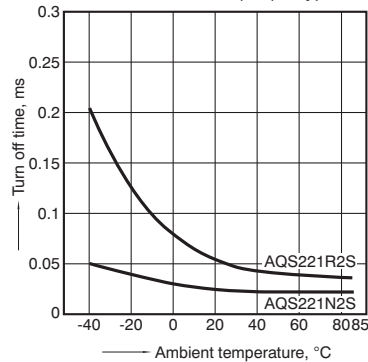

6. LED operate current vs. ambient temperature characteristics

Load voltage: 10 V (DC);
 Continuous load current: 160 mA (DC) R type/
 60 mA (DC) C type

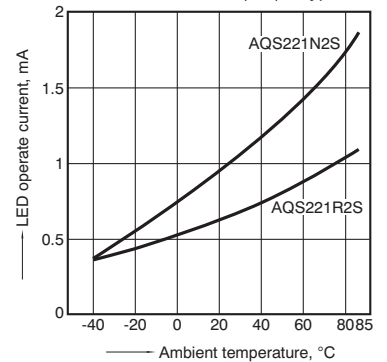

7. LED turn off current vs. ambient temperature characteristics

Load voltage: 10 V (DC);
 Continuous load current: 160 mA (DC) R type/
 60 mA (DC) C type

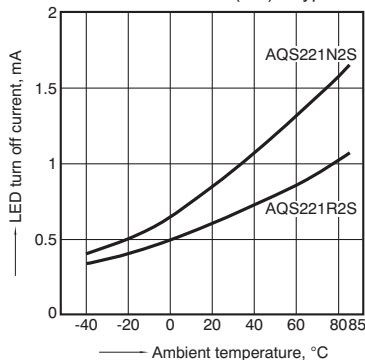

8. LED dropout voltage vs. ambient temperature characteristics

LED current: 5 to 50 mA

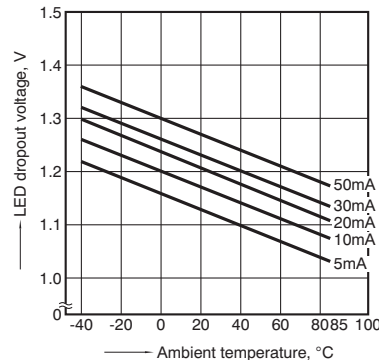

9. Current vs. voltage characteristics of output at MOS portion

Ambient temperature: 25°C 77°F

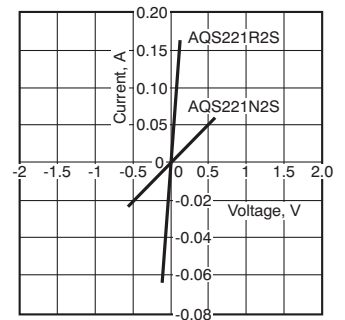

RF SOP 4 Form A C×R10 (AQS221○2S)

10. Off state leakage current vs. load voltage characteristics

Ambient temperature: 25°C 77°F

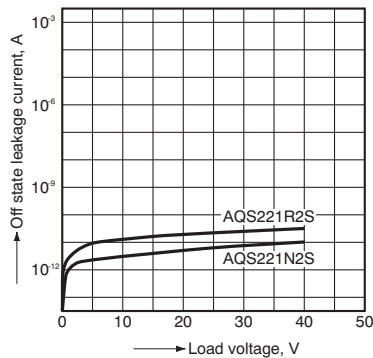

11. Turn on time vs. LED forward current characteristics

Load voltage: 10 V (DC);

Continuous load current: 160 mA (DC) R type/
20 mA (DC) C type

Ambient temperature: 25°C 77°F

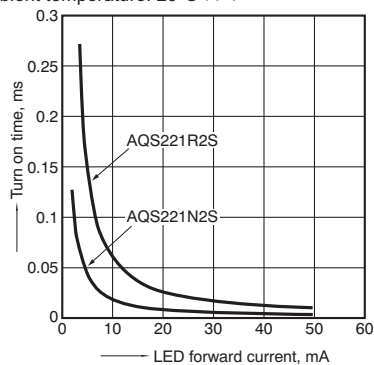

12. Turn off time vs. LED forward current characteristics

Load voltage: 10 V (DC);

Continuous load current: 160 mA (DC) R type/
20 mA (DC) C type

Ambient temperature: 25°C 77°F

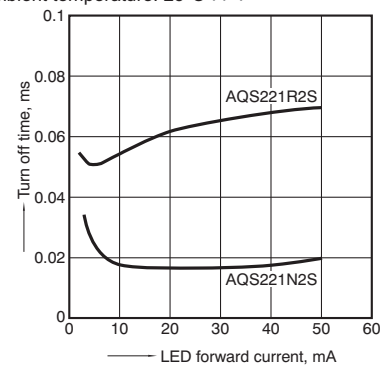

13. Output capacitance vs. applied voltage characteristics

Frequency: 1 MHz, 30 mVrms;

Ambient temperature: 25°C 77°F

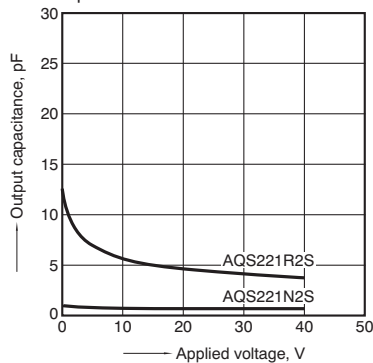

14. Isolation vs. frequency characteristics (50Ω impedance)

Ambient temperature: 25°C 77°F

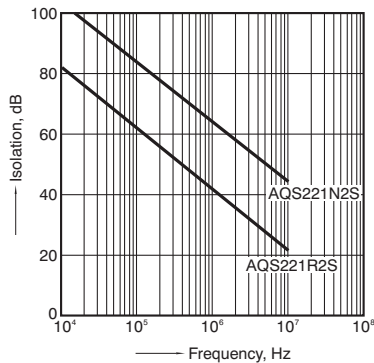

15. Insertion loss vs. frequency characteristics (50Ω impedance)

Ambient temperature: 25°C 77°F

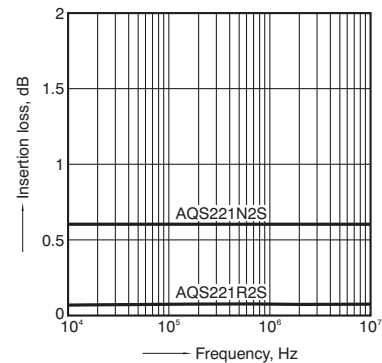

Panasonic

ideas for life

Space-saving
4-channel type
with built-in input resistor

PhotoMOS[®]
RF SOP 4 Form A C×R10
Voltage-sensitive

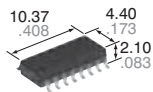

CAD Data

mm inch

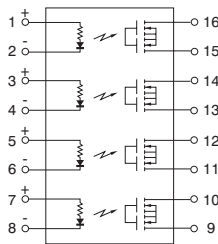

FEATURES

1. Built-in input resistor means less man-hours when mounting

The voltage-sensitive type, which eliminates the need to mount an external input resistor, is now available in a small package. Man-hours spent mounting external input resistors are cut and board designing is simplified.

2. Saves space on PC board

Since the small package size remains the same while including a built-in input resistor, space on the PC board is saved. This makes it easier to incorporate space savings when designing miniature devices.

3. Both low on-resistance (R type) and low capacitance (C type) available at excellent electrical characteristics of C×R10

- R type: On resistance 0.8Ω (typ.)
Output capacitance 14pF (typ.)
- C type: On resistance 9.5Ω (typ.)
Output capacitance 1.1pF (typ.)

TYPICAL APPLICATIONS

For multi-circuit switching;

- 1. Measuring and testing equipment**
Semiconductor testing equipment, Probe cards, Datalogger, Board tester and other testing equipment
- 2. Telecommunication and broadcasting equipment**
- 3. Medical equipment**

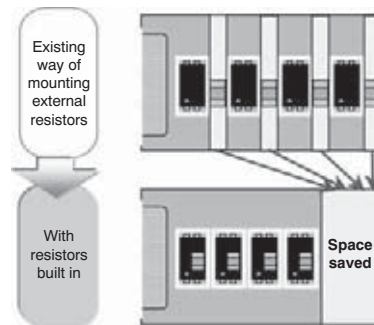

<Artistic impression of PC board space savings due to built-in resistor>
In case of SSOP.

TYPES

	Type	Output rating*1		Package	Part No.*2			Packing quantity	
		Load voltage	Load current		Tube packing style	Tape and reel packing style		Tube	Tape and reel
						Picked from the 1/2/3/4/5/6/7/8-pin side	Picked from the 9/10/11/12/13/14/15/16-pin side		
AC/DC dual use	Low on resistance (R type)	40 V	0.16A	SOP16-pin	AQS221FR2S	AQS221FR2SX	AQS221FR2SZ	1 tube contains: 50 pcs. 1 batch contains: 1,000 pcs.	1,000 pcs.
	Low capacitance (C type)	40 V	0.06A		AQS221FN2S	AQS221FN2SX	AQS221FN2SZ		

Notes: *1 Indicate the peak AC and DC values.

*2 The packing style indicator "X" or "Z" is not marked on the relay.

RATING

1. Absolute maximum ratings (Condition: ambient temperature 25°C 77°F)

Item		Symbol	AQS221FR2S	AQS221FN2S	Remarks
Input	Input voltage	V_{IN}	6V		
	Input reverse voltage	V_{RIN}	5V		
	Power dissipation	P_{in}	260mW*		*65mW for 1a
Output	Load voltage (peak AC)	V_L	40V	40V	
	Load current	I_L	0.16A	0.06A	Peak AC, DC
	Peak load current	I_{peak}	0.2A	0.12A	100ms (1shot), $V_L=DC$
	Power dissipation	P_{out}	600mW		
Total power dissipation		P_T	650mW		
I/O isolation voltage		V_{iso}	500V AC		
Operating temperature		T_{opr}	-40°C to +85°C -40°F to +185°F		Non-condensing at low temperatures
Storage temperature		T_{stg}	-40°C to +100°C -40°F to +212°F		

RF SOP 4 Form A CxR10 Voltage-sensitive (AQS221F○2S)

2. Electrical characteristics (Condition: ambient temperature 25°C 77°F)

Item		Symbol	AQS221FR2S	AQS221FN2S	Condition	
Input	Operate voltage	Typ.	1.3V		$I_L = \text{Max.}$	
		Max.	4V			
	Turn off voltage	Min.	0.8V			
		Typ.	1.3V			
Input current	Typ.	8.5mA		$V_{IN} = 5V$		
Output	On resistance	Typ.	0.75Ω	9.5Ω	$V_{IN} = 5V$ $I_L = \text{Max.}$ Within 1 s on time	
		Max.	1.25Ω	12.5Ω		
	Output capacitance	Typ.	12.5pF	1pF	$V_{IN} = 0V$ $V_B = 0V$ $f = 1\text{MHz}$	
		Max.	18pF	1.5pF		
	Off state leakage current	Typ.	0.02nA	0.01nA	$V_{IN} = 0V$ $V_L = \text{Max.}$	
		Max.	10nA			
Transfer characteristics	Turn on time*	Typ.	0.07ms	0.02ms	AQS221FR2S: $V_{IN} = 5V, I_L = \text{Max.}$ AQS221FN2S: $V_{IN} = 5V, V_L = 10V, R_L = 500\Omega$	
		Max.	0.5ms			
	Turn off time*	Typ.	0.07ms	0.02ms		
		Max.	0.2ms			
	I/O capacitance	Typ.	0.8pF			$f = 1\text{MHz}, V_B = 0V$
		Max.	1.5pF			$f = 1\text{MHz}, V_B = 0V$
Initial I/O isolation resistance	Min.	1,000MΩ		500V DC		

Note: If you wish to change the input voltage, rating or performance, please inquire with our sales.

*Turn on/Turn off time

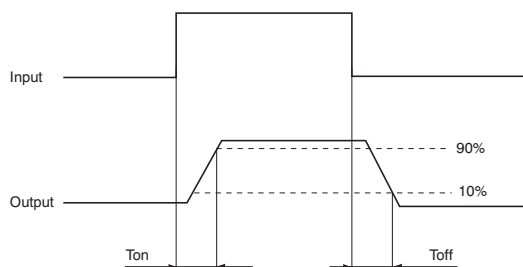

RECOMMENDED OPERATING CONDITIONS

Please obey the following conditions to ensure proper relay operation and resetting.

Item	Symbol	Minimum	Typical	Maximum	Unit
Input voltage	V_{IN}	4.5	5	5.5	V

■ For Dimensions, see Page 62.

■ For Schematic and Wiring Diagrams, see Page 67.

■ For Cautions for Use, see Page 71.

■ These products are not designed for automotive use.

If you are considering to use these products for automotive applications, please contact your local Panasonic technical representative.

For more information, see page 80.

RF SOP 4 Form A CxR10 Voltage-sensitive (AQS221F○2S)

REFERENCE DATA

1. Load current vs. ambient temperature characteristics

Allowable ambient temperature: -40°C to $+85^{\circ}\text{C}$
 -40°F to $+185^{\circ}\text{F}$

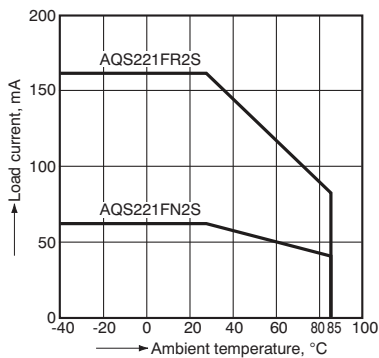

2. Load current vs. Load voltage characteristics

Ambient temperature: 25°C 77°F

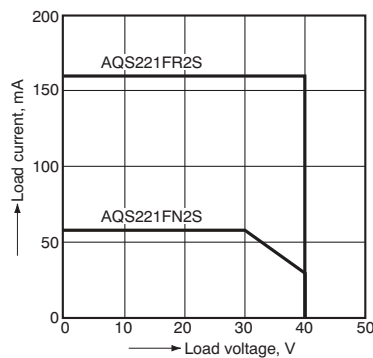

3. On resistance vs. ambient temperature characteristics

Input voltage: 5V; Load voltage: 10V (DC);
 Continuous load current: 160mA (DC) R type,
 60mA (DC) C type

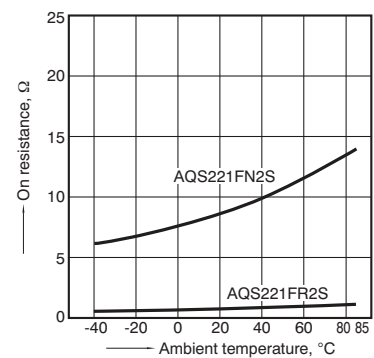

4. Turn on time vs. ambient temperature characteristics

Input voltage: 5V; Load voltage: 10V (DC);
 Continuous load current: 125mA (DC) R type,
 20mA (DC) C type

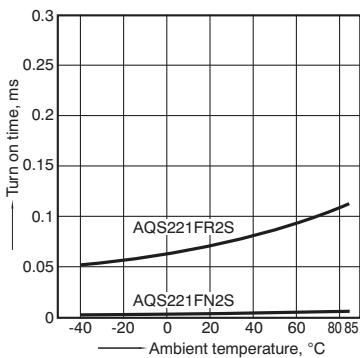

5. Turn off time vs. ambient temperature characteristics

Input voltage: 5V; Load voltage: 10V (DC);
 Continuous load current: 125mA (DC) R type,
 20mA (DC) C type

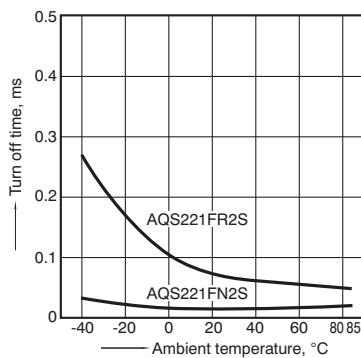

6. Turn on voltage vs. ambient temperature characteristics

Load voltage: 10V (DC);
 Continuous load current: 160mA (DC) R type,
 60mA (DC) C type

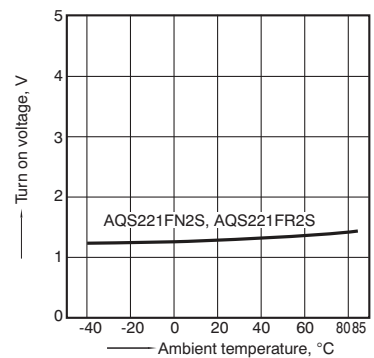

7. Turn off voltage vs. ambient temperature characteristics

Load voltage: 10V (DC);
 Continuous load current: 160mA (DC) R type,
 60mA (DC) C type

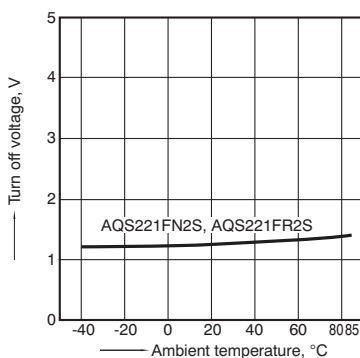

8. Input current vs. ambient temperature characteristics

Input voltage: 5V

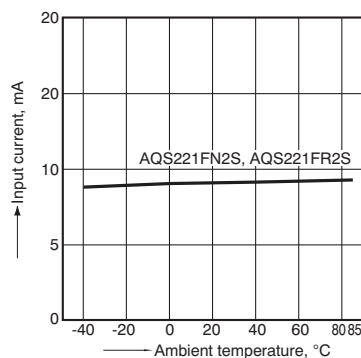

9. Current vs. voltage characteristics of output at MOS portion

Ambient temperature: 25°C 77°F

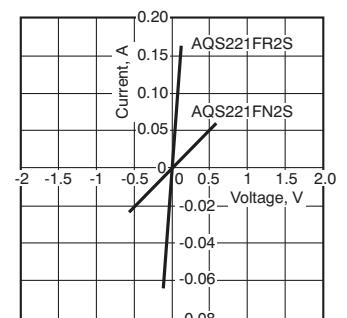

RF SOP 4 Form A CxR10 Voltage-sensitive (AQS221F○2S)

10. Input current vs. input voltage characteristics

Ambient temperature: 25°C 77°F
(Recommended input voltage: 5±0.5V)

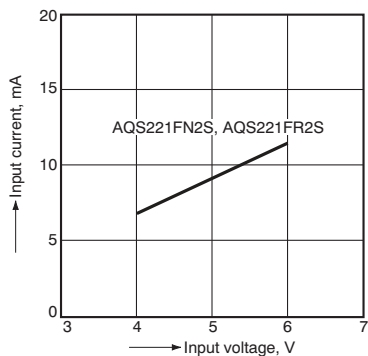

11. Off state leakage current vs. load voltage characteristics

Measured portion: between terminals 3 and 4
Ambient temperature: 25°C 77°F

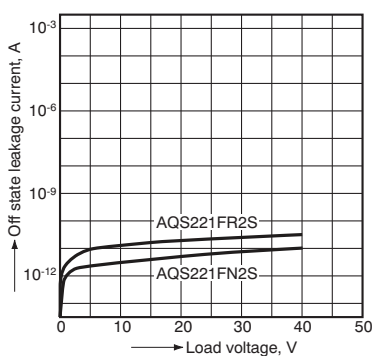

12. Turn on time vs. input voltage characteristics

Load voltage: 10V (DC);
Continuous load current: 125mA (DC) R type,
20mA (DC) C type; Ambient temperature: 25°C 77°F

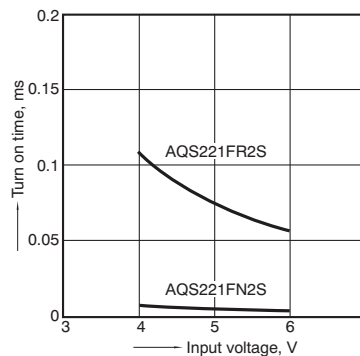

13. Turn off time vs. input voltage characteristics

Load voltage: 10V (DC);
Continuous load current: 125mA (DC) R type,
20mA (DC) C type; Ambient temperature: 25°C 77°F

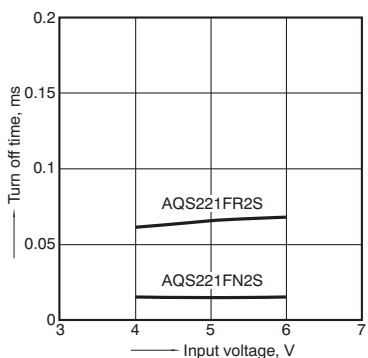

14. Output capacitance vs. applied voltage characteristics

Measured portion: between terminals 3 and 4
Frequency: 1 MHz, 30m Vrms;
Ambient temperature: 25°C 77°F

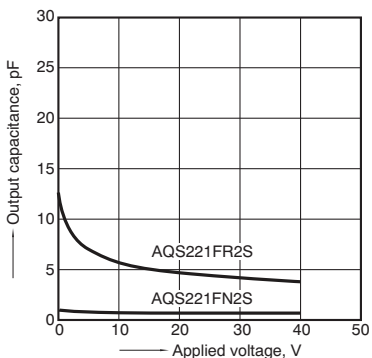

15. Isolation vs. frequency characteristics (50Ω impedance)

Measured portion: between terminals 3 and 4
Ambient temperature: 25°C 77°F

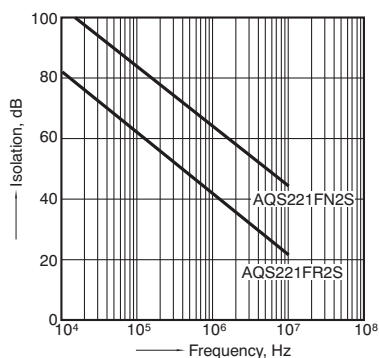

16. Insertion loss vs. frequency characteristics (50Ω impedance)

Measured portion: between terminals 3 and 4
Ambient temperature: 25°C 77°F

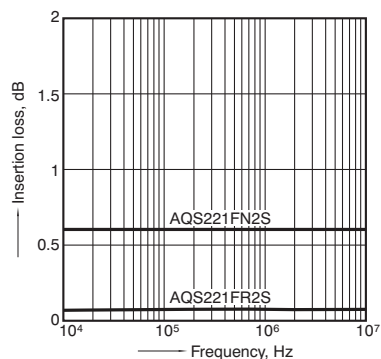

Panasonic

ideas for life

**Super miniature SSOP type
featuring low C×R
80V load voltage**

**PhotoMOS[®]
RF SSOP 1 Form A C×R
(AQY225R2V)**

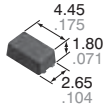

CAD Data

mm inch

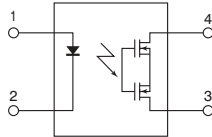

FEATURES

1. Low capacitance and on-resistance with 80V load voltage

Output capacitance (Cout): 4.5pF (typ.)

ON resistance (Ron): 10.5Ω (typ.)

2. Reduced package size

The bottom dimension has been reduced by 60% and mounting space by 40% compared to conventional SOP4-pin type.

3. Mounting space has been reduced and output signals have been improved by using new flat lead terminals.

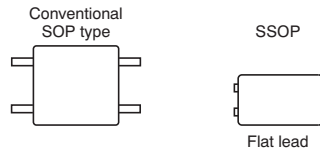

4. High speed switching

Turn on time: 0.05ms (typ.)

Turn off time: 0.05ms (typ.)

TYPICAL APPLICATIONS

1. Measuring and testing equipment

IC tester, Liquid crystal driver tester, Semiconductor performance tester, Bare board tester, In-circuit tester, function tester, etc.

2. Telecommunication and broadcasting equipment

3. Medical equipment

4. Multi-point recorder

Warping, Thermo couple, etc.

TYPES

	Output rating*1		Package	Tape and reel packing style*2		Packing quantity in tape and reel
	Load voltage	Load current		Picked from the 1/4-pin side	Picked from the 2/3-pin side	
AC/DC dual use	80 V	0.12 A	SSOP	AQY225R2VY	AQY225R2VW	3,500 pcs.

Notes: *1 Indicate the peak AC and DC values.

*2 Tape and reel is the standard packing style for SSOP.

For space reasons, the three initial letters of the part number "AQY" the package (SSOP) indicator "V" and the packing style indicator "Y" or "W" are not marked on the relay.

RATING

1. Absolute maximum ratings (Ambient temperature: 25°C 77°F)

Item		Symbol	AQY225R2V	Remarks
Input	LED forward current	I _F	50mA	
	LED reverse voltage	V _R	5V	
	Peak forward current	I _{FP}	1A	f=100 Hz, Duty factor=0.1%
	Power dissipation	P _{in}	75mW	
Output	Load voltage (peak AC)	V _L	80V	
	Continuous load current	I _L	0.12A	Peak AC, DC
	Peak load current	I _{peak}	0.3A	A connection: 100 ms (1 shot), V _L = DC
	Power dissipation	P _{out}	250mW	
Total power dissipation		P _T	300mW	
I/O isolation voltage		V _{iso}	1,500V AC	
Temperature limits	Operating	T _{opr}	-40°C to +85°C -40°F to +185°F	Non-condensing at low temperatures
	Storage	T _{stg}	-40°C to +100°C -40°F to +212°F	

RF SSOP 1 Form A C×R (AQY225R2V)

2. Electrical characteristics (Ambient temperature: 25°C 77°F)

Item		Symbol	AQY225R2V	Condition
Input	LED operate current	Typical	0.5 mA	$I_L = 80 \text{ mA}$
		Maximum	3.0 mA	
	LED turn off current	Minimum	0.1 mA	$I_L = 80 \text{ mA}$
		Typical	0.45 mA	
LED dropout voltage	Typical	V_F	1.32 V (1.14 V at $I_F = 5 \text{ mA}$)	$I_F = 50 \text{ mA}$
	Maximum		1.5 V	
Output	On resistance	Typical	10.5Ω	$I_F = 5 \text{ mA}$
		Maximum	15Ω	$I_L = 80 \text{ mA}$
	Output capacitance	Typical	4.5 pF	$I_F = 0 \text{ mA}$
		Maximum	6 pF	$V_B = 0 \text{ V}$ $f = 1 \text{ MHz}$
Off state leakage current	Typical	0.01 nA	$I_F = 0 \text{ mA}$	
	Maximum	10 nA	$V_L = \text{Max.}$	
Transfer characteristics	Turn on time*	Typical	0.05 ms	$I_F = 5 \text{ mA}$
		Maximum	0.5 ms	$V_L = 10 \text{ V}$ $R_L = 125\Omega$
	Turn off time*	Typical	0.05 ms	$I_F = 5 \text{ mA}$
		Maximum	0.2 ms	$V_L = 10 \text{ V}$ $R_L = 125\Omega$
	I/O capacitance	Typical	0.8 pF	$f = 1 \text{ MHz}$
		Maximum	1.5 pF	$V_B = 0 \text{ V}$
Initial I/O isolation resistance	Minimum	R_{iso}	1,000MΩ	500V DC

*Turn on/Turn off time

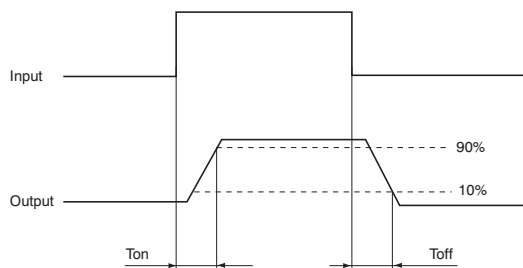

RECOMMENDED OPERATING CONDITIONS

Please obey the following conditions to ensure proper relay operation and resetting.

Item	Symbol	Recommended value	Unit
Input LED current	I_F	5	mA

■ For Dimensions, see page 62.

■ For Schematic and Wiring Diagrams, see page 64.

■ For Cautions for Use, see page 71.

■ These products are not designed for automotive use.

If you are considering to use these products for automotive applications, please contact your local Panasonic technical representative.

For more information, see page 80.

REFERENCE DATA

16. Load current vs. ambient temperature characteristics

Allowable ambient temperature: -40°C to +85°C
-40°F to +185°F

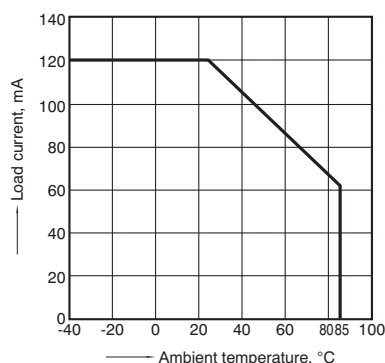

17. On resistance vs. ambient temperature characteristics

Measured portion: between terminals 3 and 4
LED current: 5 mA; Load voltage: 10V (DC);
Load current: 80mA (DC)

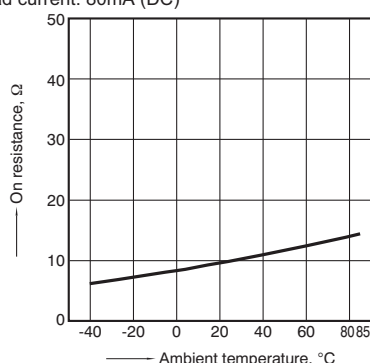

18. Turn on time vs. ambient temperature characteristics

LED current: 5 mA; Load voltage: 10V (DC);
Continuous load current: 80mA (DC)

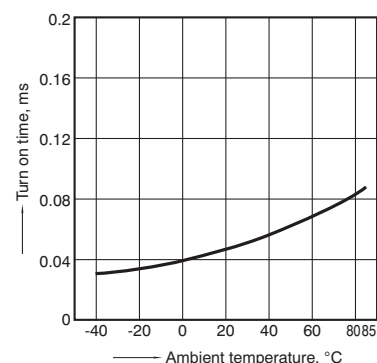

RF SSOP 1 Form A C×R (AQY225R2V)

19. Turn off time vs. ambient temperature characteristics

LED current: 5 mA; Load voltage: 10V (DC);
Continuous load current: 80mA (DC)

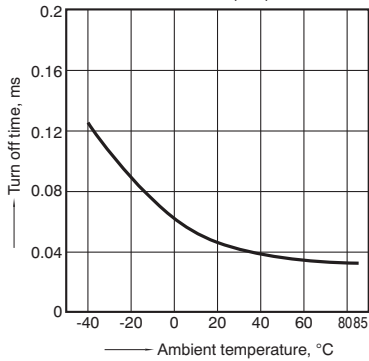

20. LED operate current vs. ambient temperature characteristics

Load voltage: 10V (DC);
Continuous load current: 80mA (DC)

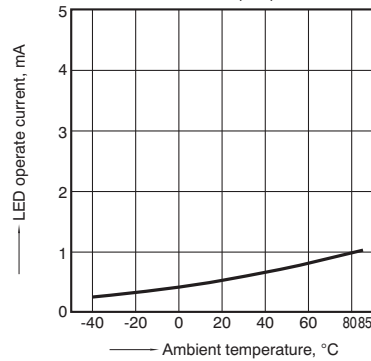

21. LED turn off current vs. ambient temperature characteristics

Load voltage: 10V (DC);
Continuous load current: 80mA (DC)

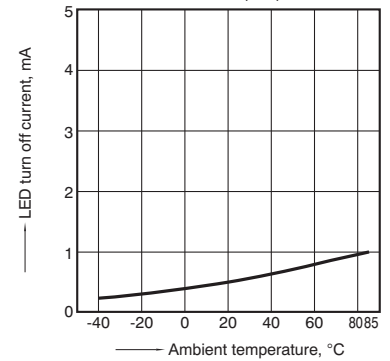

22. LED dropout voltage vs. ambient temperature characteristics

LED current: 5 to 50 mA

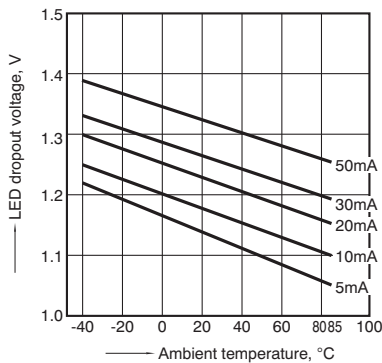

23. Current vs. voltage characteristics of output at MOS portion

Measured portion: between terminals 3 and 4
Ambient temperature: 25°C 77°F

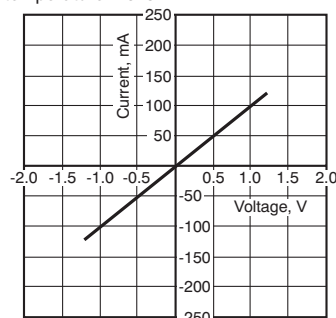

24. Off state leakage current vs. load voltage characteristics

Measured portion: between terminals 3 and 4
Ambient temperature: 25°C 77°F

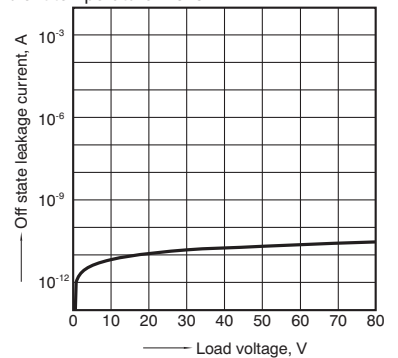

25. Turn on time vs. LED forward current characteristics

Measured portion: between terminals 3 and 4
Load voltage: 10V (DC); Continuous load current:
80mA (DC); Ambient temperature: 25°C 77°F

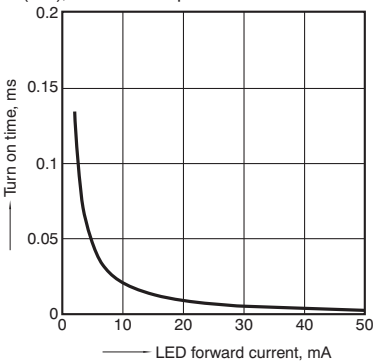

26. Turn off time vs. LED forward current characteristics

Measured portion: between terminals 3 and 4
Load voltage: 10V (DC); Continuous load current:
80mA (DC); Ambient temperature: 25°C 77°F

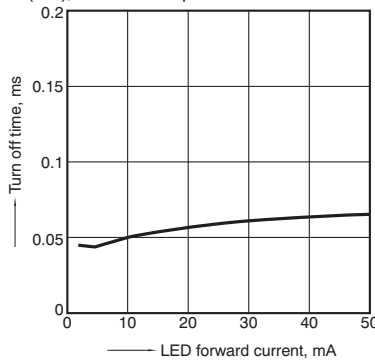

27. Output capacitance vs. applied voltage characteristics

Measured portion: between terminals 3 and 4
Frequency: 1 MHz, 30m Vrms; Ambient temperature:
25°C 77°F

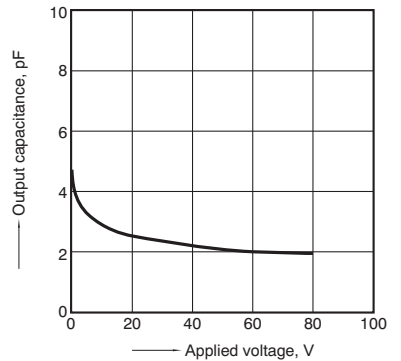

Panasonic

ideas for life

Miniature SOP4-pin type
featuring low C×R
60V/80V load voltage

PhotoMOS®
RF SOP 1 Form A C×R
(AQY22OROS)

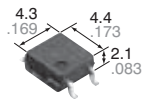

CAD Data

mm inch

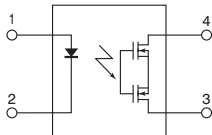

FEATURES

1. Low capacitance and low on resistance (Load voltage: 60 to 80V)

	AQY222R1S	AQY225R1S	AQY225R2S
Output capacitance (C _{out})	24.5pF (typ.)	37.5pF (typ.)	4.5pF (typ.)
On resistance (R _{on})	0.8Ω (typ.)	0.8Ω (typ.)	10.5Ω (typ.)

2. Miniature SOP4-pin package

(W)4.3 × (L)4.4 × (H)2.1 mm

(W).169 × (L).173 × (H).083 inch

3. Low-level off-state leakage current of typ. 0.01 nA (AQY225R2S)

4. Controls low-level analog signals

TYPICAL APPLICATIONS

1. Measuring and testing equipment

IC tester, Liquid crystal driver tester, Semiconductor performance tester, Bare board tester, In-circuit tester, Function tester, etc.

2. Telecommunication and broadcasting equipment

3. Medical equipment

4. Multi-point recorder

Warping, Thermo couple

TYPES

	Output rating*		Package	Part No.			Packing quantity	
	Load voltage	Load current		Tube packing style	Tape and reel packing style		Tube	Tape and reel
					Picked from the 1/2-pin side	Picked from the 3/4-pin side		
AC/DC dual use	60V	0.5A	SOP4-pin	AQY222R1S	AQY222R1SX	AQY222R1SZ	1 tube contains: 100 pcs. 1 batch contains: 2,000 pcs.	1,000 pcs.
	80V	0.35A		AQY225R1S	AQY225R1SX	AQY225R1SZ		
	80V	0.15A		AQY225R2S	AQY225R2SX	AQY225R2SZ		

* Indicate the peak AC and DC values.

Note: For space reasons, the three initial letters of the part number "AQY", the package (SOP) indicator "S" and the packing style indicator "X" or "Z" are not marked on the relay. (Ex. the label for product number AQY222R1SX is 222R1)

RATING

1. Absolute maximum ratings (Ambient temperature: 25°C 77°F)

	Item	Symbol	AQY222R1S	AQY225R1S	AQY225R2S	Remarks
Input	LED forward current	I _F	50mA			
	LED reverse voltage	V _R	5V			
	Peak forward current	I _{FP}	1A			f=100 Hz, Duty factor=0.1%
	Power dissipation	P _{in}	75mW			
Output	Load voltage (peak AC)	V _L	60V	80V		
	Continuous load current	I _L	0.5A	0.35A	0.15A	Peak AC, DC
	Peak load current	I _{peak}	1A	0.7A	0.45A	100 ms (1 shot), V _L = DC
	Power dissipation	P _{out}	300mW			
Total power dissipation	P _T	350mW				
I/O isolation voltage	V _{iso}	1,500V AC				
Temperature limits	Operating	T _{opr}	-40°C to +85°C -40°F to +185°F			Non-condensing at low temperatures
	Storage	T _{stg}	-40°C to +100°C -40°F to +212°F			

RF SOP 1 Form A C×R (AQY22○R○S)

2. Electrical characteristics (Ambient temperature: 25°C 77°F)

Item			Symbol	AQY222R1S	AQY225R1S	AQY225R2S	Condition
Input	LED operate current	Typical	I_{Fon}	0.5 mA			$I_L = \text{Max.}$
		Maximum		3.0 mA			
	LED turn off current	Minimum	I_{Foff}	0.1 mA			$I_L = \text{Max.}$
		Typical		0.45 mA			
LED dropout voltage	Typical	V_F	1.32 V (1.14 V at $I_F = 5 \text{ mA}$)			$I_F = 50 \text{ mA}$	
	Maximum		1.5 V				
Output	On resistance	Typical	R_{on}	0.8Ω	10.5Ω		$I_F = 5 \text{ mA}$ $I_L = \text{Max.}$
		Maximum		1.2Ω		15Ω	
	Output capacitance	Typical	C_{out}	24.5 pF	37.5 pF	4.5 pF	$I_F = 0 \text{ mA}$, $f = 1 \text{ MHz}$, $V_B = 0 \text{ V}$ (amplitude of 30mV) Measured from 10s onward after application
		Maximum		30 pF	45 pF	6.0 pF	
	Off state leakage current	Typical	I_{Leak}	0.05 nA	0.03 nA	0.01 nA	$I_F = 0 \text{ mA}$ $V_L = \text{Max.}$
Maximum		10 nA					
Transfer characteristics	Turn on time*	Typical	T_{on}	0.15 ms	0.25 ms	0.05 ms	$I_F = 5 \text{ mA}$ $V_L = 10 \text{ V}$ $R_L = 100\Omega$
		Maximum		0.5ms		0.75ms	
	Turn off time*	Typical	T_{off}	0.06 ms	0.08 ms	0.05 ms	$I_F = 5 \text{ mA}$ $V_L = 10 \text{ V}$ $R_L = 100\Omega$
		Maximum		0.2 ms			
	I/O capacitance	Typical	C_{iso}	0.8 pF			$f = 1 \text{ MHz}$ $V_B = 0 \text{ V}$
Maximum		1.5 pF					
Initial I/O isolation resistance	Minimum	R_{iso}	1,000MΩ		500 V DC		

*Turn on/Turn off time

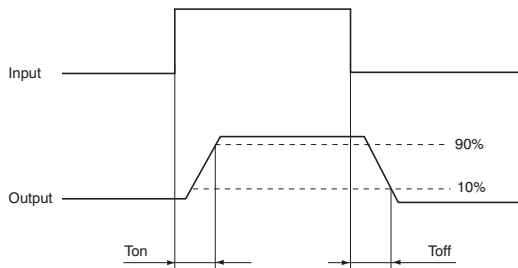

RECOMMENDED OPERATING CONDITIONS

Please obey the following conditions to ensure proper relay operation and resetting.

Item	Symbol	Recommended value	Unit
Input LED current	I_F	5	mA

■ For Dimensions, see Page 62.

■ For Schematic and Wiring Diagrams, see Page 64.

■ For Cautions for Use, see Page 71.

■ These products are not designed for automotive use.

If you are considering to use these products for automotive applications, please contact your local Panasonic technical representative.

For more information, see page 80.

RF SOP 1 Form A C×R (AQY22○R○S)

REFERENCE DATA

28. Load current vs. ambient temperature characteristics

Allowable ambient temperature: -40°C to +85°C
-40°F to +185°F

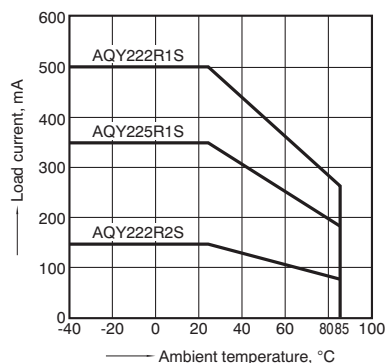

29-(1) On resistance vs. ambient temperature characteristics

Measured portion: between terminals 3 and 4
LED current: 5 mA; Load voltage: Max. (DC)
Continuous load current: Max. (DC)

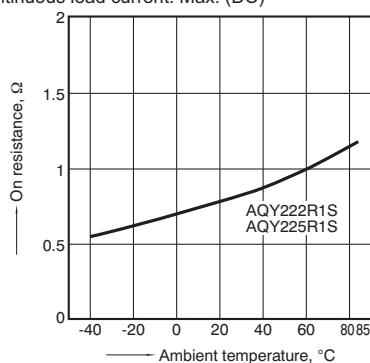

29-(2) On resistance vs. ambient temperature characteristics

Measured portion: between terminals 3 and 4
LED current: 5 mA; Load voltage: Max. (DC)
Continuous load current: Max. (DC)

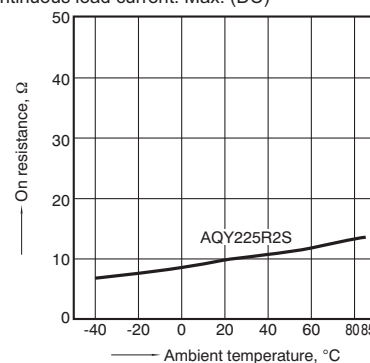

30. Turn on time vs. ambient temperature characteristics

LED current: 5 mA; Load voltage: 10V (DC)
Continuous load current: 100mA (DC)

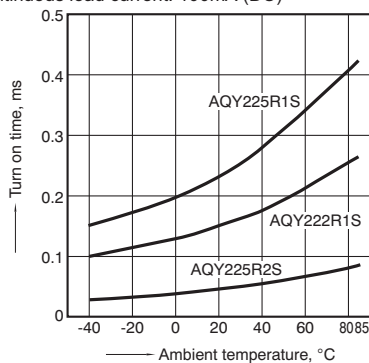

31. Turn off time vs. ambient temperature characteristics

LED current: 5 mA; Load voltage: 10V (DC)
Continuous load current: 100mA (DC)

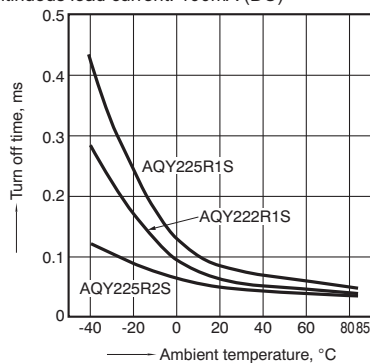

32. LED operate current vs. ambient temperature characteristics

Load voltage: Max. (DC)
Continuous load current: Max. (DC)

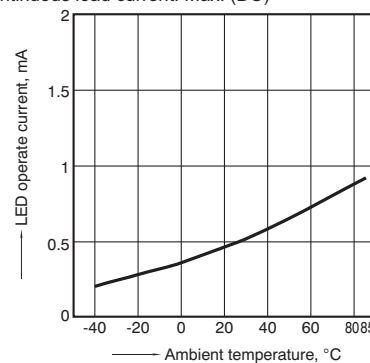

33. LED turn off current vs. ambient temperature characteristics

Load voltage: Max. (DC)
Continuous load current: Max. (DC)

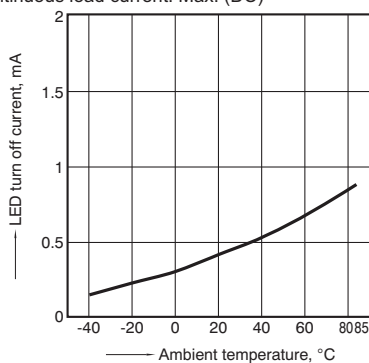

34. LED dropout voltage vs. ambient temperature characteristics

LED current: 5 to 50 mA

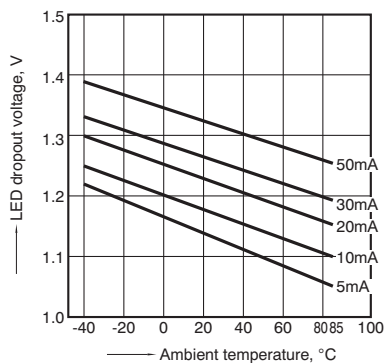

35-(1) Current vs. voltage characteristics of output at MOS portion

Measured portion: between terminals 3 and 4
Ambient temperature: 25°C 77°F

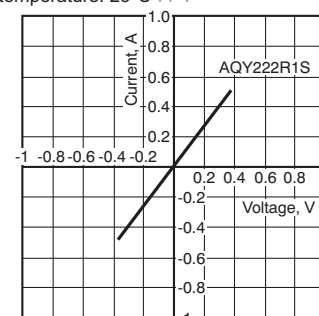

RF SOP 1 Form A C×R (AQY22○R○S)

8.-(2) Current vs. voltage characteristics of output at MOS portion

Measured portion: between terminals 3 and 4
Ambient temperature: 25°C 77°F

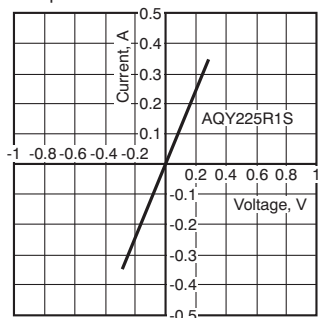

8.-(3) Current vs. voltage characteristics of output at MOS portion

Measured portion: between terminals 3 and 4
Ambient temperature: 25°C 77°F

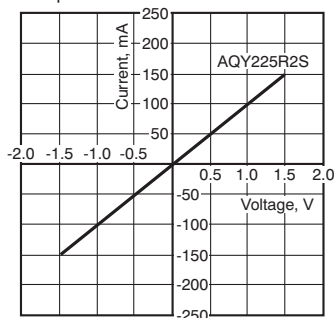

36. Off state leakage current vs. load voltage characteristics

Measured portion: between terminals 3 and 4
Ambient temperature: 25°C 77°F

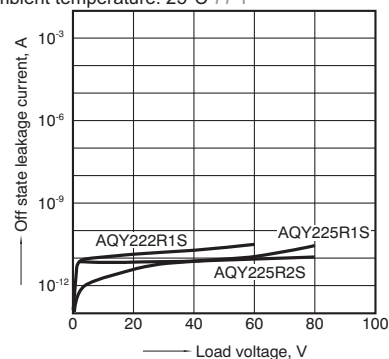

37. Turn on time vs. LED forward current characteristics

Measured portion: between terminals 3 and 4
Load voltage: 10V (DC)
Continuous load current: 100mA (DC)
Ambient temperature: 25°C 77°F

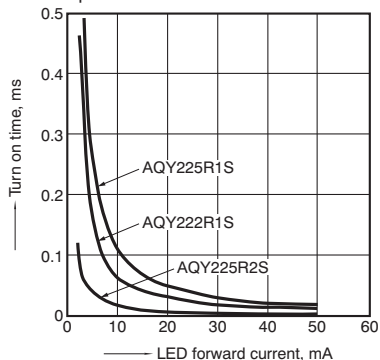

38. Turn off time vs. LED forward current characteristics

Measured portion: between terminals 3 and 4
Load voltage: 10V (DC)
Continuous load current: 100mA (DC)
Ambient temperature: 25°C 77°F

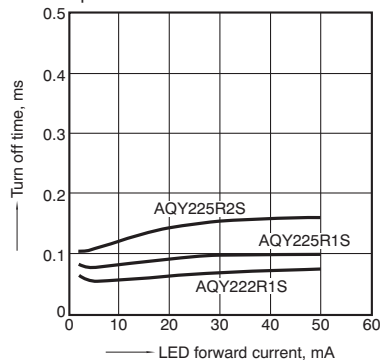

39.-(1) Output capacitance vs. applied voltage characteristics

Measured portion: between terminals 3 and 4
Frequency: 1 MHz, 30m Vrms
Ambient temperature: 25°C 77°F

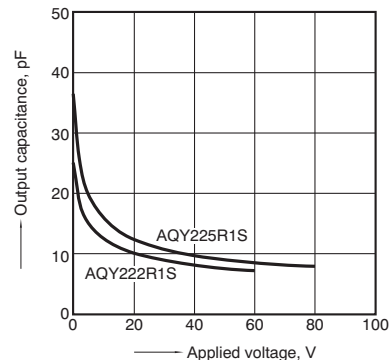

12.-(2) Output capacitance vs. applied voltage characteristics

Measured portion: between terminals 3 and 4
Frequency: 1 MHz, 30m Vrms
Ambient temperature: 25°C 77°F

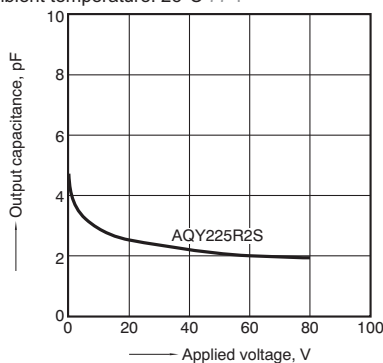

PhotoMOS

Panasonic

ideas for life



Miniature SOP8-pin type
featuring low C×R with
high load voltage of 250V

PhotoMOS®
RF SOP 2 Form A C×R
(AQW223R2S)

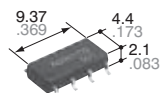

CAD Data

mm inch

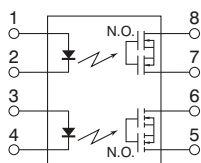

FEATURES

1. With high load voltage of 250V, low output capacitance and low on-resistance.

Output capacitance (C_{out}): 33 pF (typ.)

On-resistance (R_{on}): 11Ω (typ.)

2. 2-channel (Form A) in miniature SOP8-pin package

(W) 4.4 × (L) 9.37 × (H) 2.1 mm

(W) .173 × (L) .369 × (H) .083 inch

3. Low-level off-state leakage current of typ. 0.03 nA

4. Controls low-level analog signals

TYPICAL APPLICATIONS

1. Measuring and testing equipment

IC tester, Liquid crystal driver tester, Semiconductor performance tester, Bare board tester, In-circuit tester, Function tester, etc.

2. Telecommunication and broadcasting equipment

3. Medical equipment

4. Multi-point recorder

Warping, Thermo couple

TYPES

	Output rating*		Package	Part No.			Packing quantity	
	Load voltage	Load current		Tube packing style	Tape and reel packing style		Tube	Tape and reel
					Picked from the 1/2/3/4-pin side	Picked from the 5/6/7/8-pin side		
AC/DC dual use	250V	0.14A	SOP8-pin	AQW223R2S	AQW223R2SX	AQW223R2SZ	1 tube contains: 50 pcs. 1 batch contains: 1,000 pcs.	1,000 pcs.

* Indicate the peak AC and DC values.

Note: The packing style indicator "X" or "Z" is not marked on the relay.

RATING

1. Absolute maximum ratings (Ambient temperature: 25°C 77°F)

Item		Symbol	AQW223R2S	Remarks
Input	LED forward current	I _F	50 mA	
	LED reverse voltage	V _R	5 V	
	Peak forward current	I _{FP}	1 A	f = 100 Hz, Duty factor = 0.1%
	Power dissipation	P _{in}	75 mW	
Output	Load voltage (peak AC)	V _L	250 V	
	Continuous load current	I _L	0.14 A (0.17 A)	Peak AC, DC (): in case of using only 1a (1 channel)
	Peak load current	I _{peak}	0.42 A	100 ms (1 shot), V _L = DC
	Power dissipation	P _{out}	600 mW	
Total power dissipation		P _T	650 mW	
I/O isolation voltage		V _{iso}	1,500 V AC	
Temperature limits	Operating	T _{opr}	-40°C to +85°C -40°F to +185°F	Non-condensing at low temperatures
	Storage	T _{stg}	-40°C to +100°C -40°F to +212°F	

RF SOP 2 Form A C×R (AQW223R2S)

2. Electrical characteristics (Ambient temperature: 25°C 77°F)

Item		Symbol	AQW223R2S	Condition	
Input	LED operate current	Typical	0.5mA	$I_L = \text{Max.}$	
		Maximum	3.0mA		
	LED turn off current	Minimum	0.1mA	$I_L = \text{Max.}$	
		Typical	0.45mA		
LED dropout voltage	Typical	V_F	1.32V (1.14V at $I_F = 5\text{mA}$)	$I_F = 50\text{mA}$	
	Maximum				1.5V
Output	On resistance	Typical	R_{on}	$I_F = 5\text{mA}$	
		Maximum	R_{on}	$I_L = \text{Max.}$	
	Output capacitance	Typical	C_{out}	33pF	$I_F = 0\text{mA}$
		Maximum		40pF	$f = 1\text{MHz}$ $V_B = 0\text{V}$
	Off state leakage current	Typical	I_{Leak}	0.03nA	$I_F = 0\text{mA}$
Maximum		10nA		$V_L = \text{Max.}$	
Transfer characteristics	Turn on time*	Typical	T_{on}	0.15ms	
		Maximum		0.5ms	$I_F = 5\text{mA}$ $I_L = \text{Max.}$
	Turn off time*	Typical	T_{off}	0.05ms	$I_F = 5\text{mA}$ or 10mA
		Maximum		0.2ms	$I_L = \text{Max.}$
	I/O capacitance	Typical	C_{iso}	0.8pF	$f = 1\text{MHz}$
		Maximum		1.5pF	$V_B = 0\text{V}$
Initial I/O isolation resistance	Minimum	R_{iso}	1,000M Ω	500V DC	

*Turn on/Turn off time

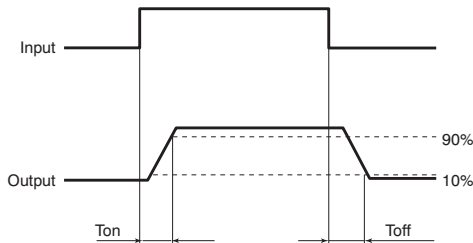

RECOMMENDED OPERATING CONDITIONS

Please obey the following conditions to ensure proper relay operation and resetting.

Item	Symbol	Recommended value	Unit
Input LED current	I_F	5	mA

■ For Dimensions, see Page 62.

■ For Schematic and Wiring Diagrams, see Page 65.

■ For Cautions for Use, see Page 71.

■ These products are not designed for automotive use.

If you are considering to use these products for automotive applications, please contact your local Panasonic technical representative.

For more information, see page 80.

REFERENCE DATA

1. Load current vs. ambient temperature characteristics

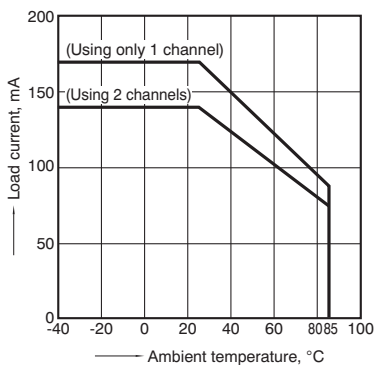
Allowable ambient temperature: -40°C to $+85^\circ\text{C}$
 -40°F to $+185^\circ\text{F}$ 

2. On resistance vs. ambient temperature characteristics

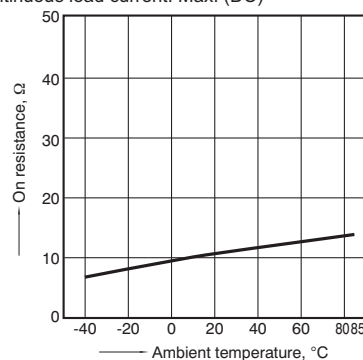
Measured portion: between terminals 5 and 6, 7 and 8:
LED current: 5 mA;
Load voltage: Max. (DC);
Continuous load current: Max. (DC)

3. Turn on time vs. ambient temperature characteristics

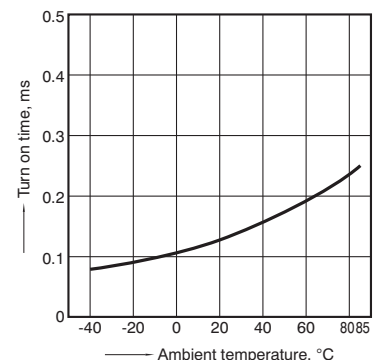
LED current: 5 mA;
Load voltage: Max. (DC);
Continuous load current: Max. (DC)

RF SOP 2 Form A C×R (AQW223R2S)

4. Turn off time vs. ambient temperature characteristics

LED current: 5 mA; Load voltage: Max. (DC);
Continuous load current: Max. (DC)

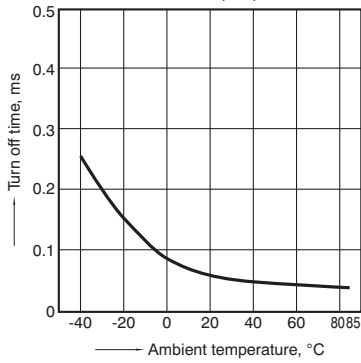

5. LED operate current vs. ambient temperature characteristics

Load voltage: Max. (DC);
Continuous load current: Max. (DC)

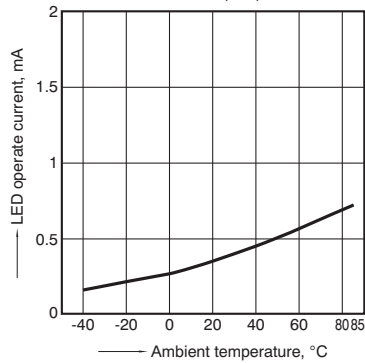

6. LED turn off current vs. ambient temperature characteristics

Load voltage: Max. (DC);
Continuous load current: Max. (DC)

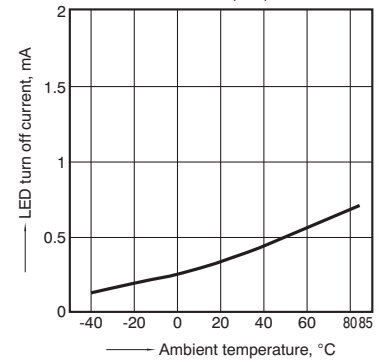

7. LED dropout voltage vs. ambient temperature characteristics

LED current: 5 to 50 mA

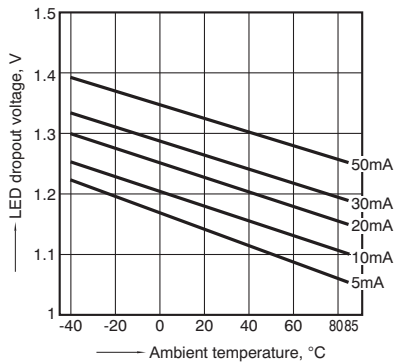

8. Current vs. voltage characteristics of output at MOS portion

Measured portion: between terminals 5 and 6,
7 and 8;

Ambient temperature: 25°C 77°F

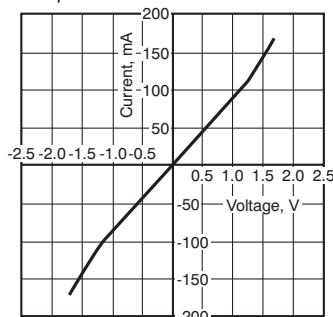

9. Off state leakage current vs. load voltage characteristics

Measured portion: between terminals 5 and 6,
7 and 8;

Ambient temperature: 25°C 77°F

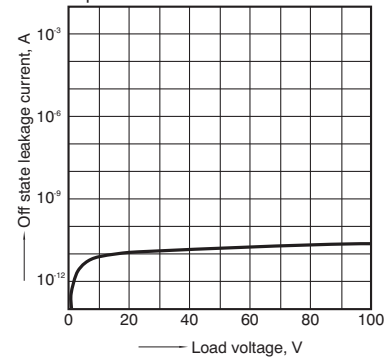

10. Turn on time vs. LED forward current characteristics

Measured portion: between terminals 5 and 6, 7 and 8;
Load voltage: Max. (DC);

Continuous load current: Max. (DC);

Ambient temperature: 25°C 77°F

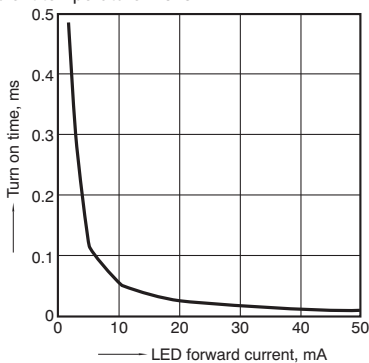

11. Turn off time vs. LED forward current characteristics

Measured portion: between terminals 5 and 6, 7 and 8;
Load voltage: Max. (DC);

Continuous load current: Max. (DC);

Ambient temperature: 25°C 77°F

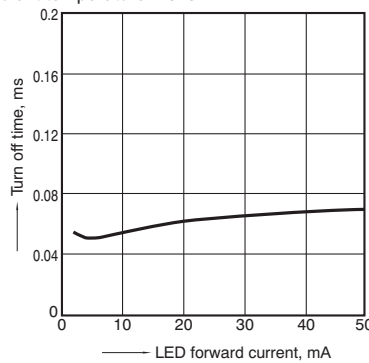

12. Output capacitance vs. applied voltage characteristics

Measured portion: between terminals 5 and 6, 7 and 8;
Frequency: 1 MHz, 30 mVrms;

Ambient temperature: 25°C 77°F

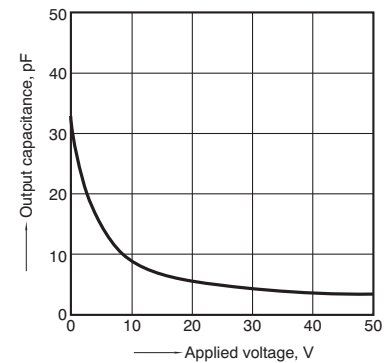

Panasonic

ideas for life

**Miniature SOP6-pin type
featuring low on-resistance
with 200V/400V
load voltage**

**PhotoMOS[®]
RF SOP 1 Form A**
Low on-resistance (AQV22ONS)

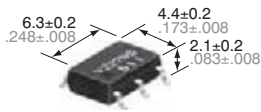

CAD Data

mm inch

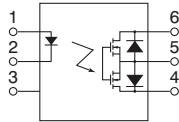

FEATURES

1. Miniature SOP4-pin package
(W) 4.4 × (L) 6.3 × (H) 2.1 mm (W) .173 ×
(L) .248 × (H) .083 inch —approx. 25% of
the volume and 50% of the footprint size of
DIP type PhotoMOS Relays.

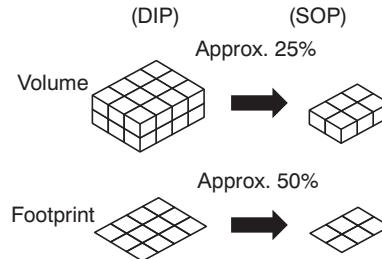

**2. Low output capacitance and high
response speed**

The capacitance between output
terminals is small; typ. 10pF. This
enables a fast operation speed of typ.
0.1ms (AQY224NS).

3. Low-level off state leakage current
4. Controls low-level analog signals

TYPICAL APPLICATIONS

- Telephones
- Measuring instruments
- Computers
- Industrial robots
- High-speed inspection machines

TYPES

	Output rating*		Package	Part No.			Packing quantity	
	Load voltage	Load current		Tube packing style	Tape and reel packing style		Tube	Tape and reel
					Picked from the 1/2/3-pin side	Picked from the 4/5/6-pin side		
AC/DC dual use	200 V	50 mA	SOP6-pin	AQV227NS	AQV227NSX	AQV227NSZ	1 tube contains: 75 pcs.	1,000 pcs.
	400 V	40 mA		AQV224NS	AQV224NSX	AQV224NSZ	1 batch contains: 1,000 pcs.	

*Indicate the peak AC and DC values.

Note: For space reasons, the two initial letters of the part number "AQ" and the packing style indicator "X" or "Z" are not marked on the relay.
(Ex. the label for product number AQV227NS is V227NS)

RATING

1. Absolute maximum ratings (Ambient temperature: 25°C 77°F)

Item		Symbol	Type of connection	AQV227NS	AQV224NS	Remarks
Input	LED forward current	I_F		50 mA		
	LED reverse voltage	V_R		5 V		
	Peak forward current	I_{FP}		1 A		$f = 100 \text{ Hz}$, Duty factor = 0.1%
	Power dissipation	P_{in}		75 mW		
Output	Load voltage (peak AC)	V_L		200 V	400 V	
	Continuous load current	I_L	A	0.05 A	0.04 A	A connection: Peak AC, DC
			B	0.06 A	0.05 A	B, C connection: DC
			C	0.08 A	0.06 A	
	Peak load current	I_{peak}		0.15 A	0.12 A	A connection: 100 ms (1 shot), $V_L = \text{DC}$
	Power dissipation	P_{out}		450 mW		
Total power dissipation	P_T		500 mW			
I/O isolation voltage		V_{iso}		1,500 V AC		
Temperature limits	Operating	T_{opr}		-40°C to +85°C -40°F to +185°F		Non-condensing at low temperatures
	Storage	T_{stg}		-40°C to +100°C -40°F to +212°F		

RF SOP 1 Form A Low on-resistance (AQV22○NS)

2. Electrical characteristics (Ambient temperature: 25°C 77°F)

Item		Symbol	Type of connection	AQV227NS	AQV224NS	Remarks	
Input	LED operate current	Typical	I _{Fon}	0.7 mA		I _L = Max.	
		Maximum		3 mA			
	LED turn off current	Minimum	I _{Foff}	0.4 mA		I _L = Max.	
		Typical		0.65 mA			
LED dropout voltage	Typical	V _F	1.25 V (1.14 V at I _F = 5 mA)		I _F = 50 mA		
	Maximum		1.5 V				
Output	On resistance	Typical	R _{on}	A	30 Ω	70 Ω	I _F = 5 mA I _L = Max. Within 1 s on time
		Maximum		50 Ω	100 Ω		
		Typical	R _{on}	B	16 Ω	55 Ω	I _F = 5 mA I _L = Max. Within 1 s on time
		Maximum		25 Ω	70 Ω		
	Typical	R _{on}	C	8 Ω	28 Ω	I _F = 5 mA I _L = Max. Within 1 s on time	
	Maximum			12.5 Ω	35 Ω		
Output capacitance	Typical	C _{out}	10 pF		I _F = 0 V _B = 0 f = 1 MHz		
Maximum	15 pF						
Off state leakage current	Maximum	I _{leak}	10 nA		I _F = 0 V _L = Max.		
Transfer characteristics	Turn on time*	Typical	T _{on}	0.12 ms	0.1 ms	I _F = 5 mA I _L = Max.	
		Maximum		0.5 ms			
	Turn off time*	Typical	T _{off}	0.05 ms		I _F = 5 mA I _L = Max.	
		Maximum		0.2 ms			
	I/O capacitance	Typical	C _{iso}	0.8 pF		f = 1 MHz V _B = 0	
Maximum		1.5 pF					
Initial I/O isolation resistance	Minimum	R _{iso}	1,000 MΩ		500 V DC		

*Turn on/Turn off time

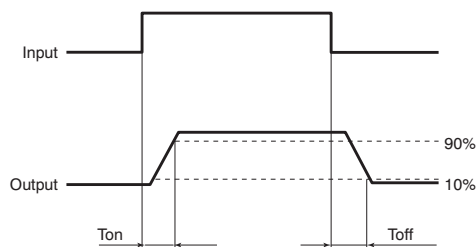

RECOMMENDED OPERATING CONDITIONS

Please obey the following conditions to ensure proper relay operation and resetting.

Item	Symbol	Recommended value	Unit
Input LED current	I _F	5	mA

■ For Dimensions, see Page 62.

■ For Schematic and Wiring Diagrams, see Page 65.

■ For Cautions for Use, see Page 71.

■ These products are not designed for automotive use.

If you are considering to use these products for automotive applications, please contact your local Panasonic technical representative.

For more information, see page 80.

RF SOP 1 Form A Low on-resistance (AQV22○NS)

REFERENCE DATA

1. Load current vs. ambient temperature characteristics

Allowable ambient temperature: -40°C to $+85^{\circ}\text{C}$
 -40°F to $+185^{\circ}\text{F}$

Type of connection: A

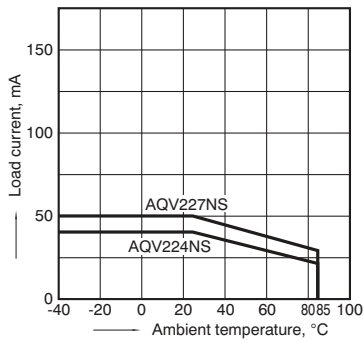

2. On resistance vs. ambient temperature characteristics

Measured portion: between terminals 4 and 6;
 LED current: 5 mA;
 Load voltage: Max. (DC);
 Continuous load current: Max. (DC)

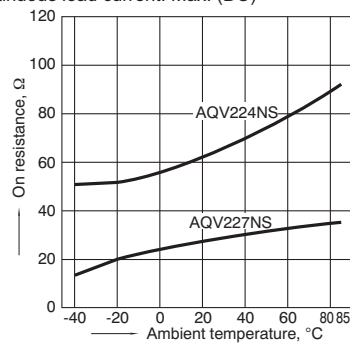

3. Turn on time vs. ambient temperature characteristics

LED current: 5 mA;
 Load voltage: Max. (DC);
 Continuous load current: Max. (DC)

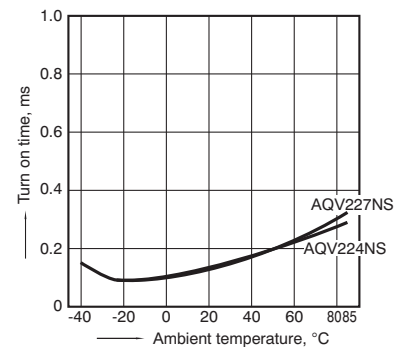

4. Turn off time vs. ambient temperature characteristics

LED current: 5 mA;
 Load voltage: Max. (DC);
 Continuous load current: Max. (DC)

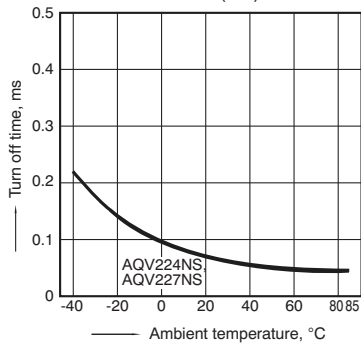

5. LED operate current vs. ambient temperature characteristics

Load voltage: Max. (DC);
 Continuous load current: Max. (DC)

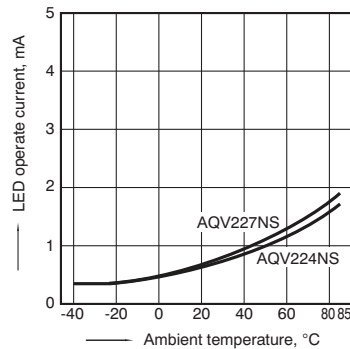

6. LED turn off current vs. ambient temperature characteristics

Load voltage: Max. (DC);
 Continuous load current: Max. (DC)

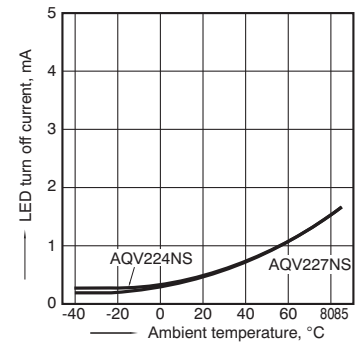

7. LED dropout voltage vs. ambient temperature characteristics

Sample: All types;
 LED current: 5 to 50 mA

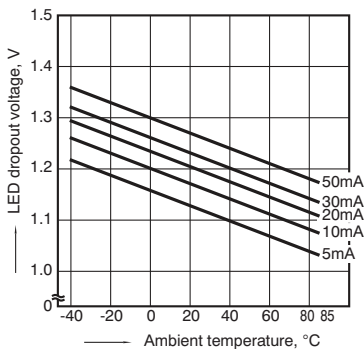

8. Voltage vs. current characteristics of output at MOS portion

Measured portion: between terminals 5 and 6,
 7 and 8;
 Ambient temperature: 25°C 77°F

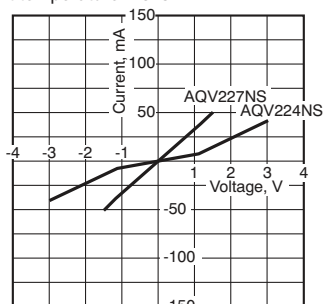

9. Off state leakage current

Measured portion: between terminals 4 and 6;
 Ambient temperature: 25°C 77°F

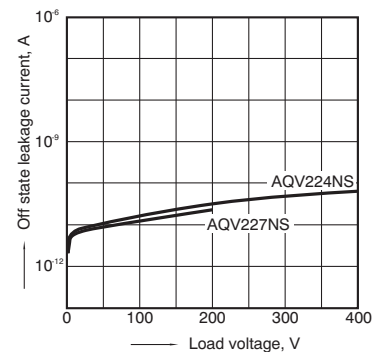

RF SOP 1 Form A Low on-resistance (AQV22○NS)

10.LED forward current vs. turn on time characteristics

Measured portion: between terminals 4 and 6;
Load voltage: Max. (DC);
Continuous load current: Max. (DC);
Ambient temperature: 25°C 77°F

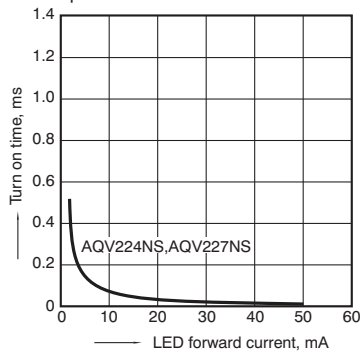

11.LED forward current vs. turn off time characteristics

Measured portion: between terminals 4 and 6;
Load voltage: Max. (DC);
Continuous load current: Max. (DC);
Ambient temperature: 25°C 77°F

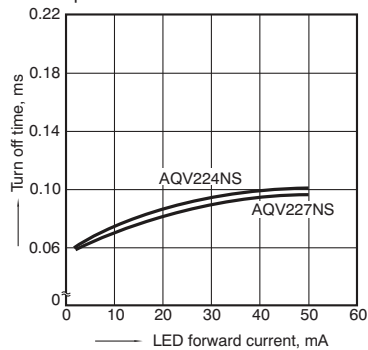

12.Applied voltage vs. output capacitance characteristics

Measured portion: between terminals 4 and 6;
Frequency: 1 MHz, 30 mVrms;
Ambient temperature: 25°C 77°F

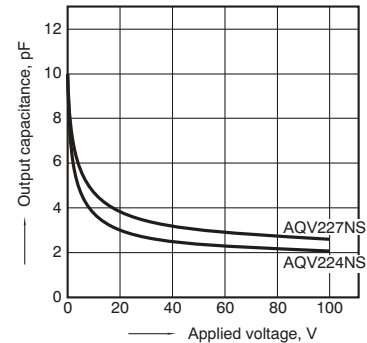

13.Isolation characteristics (50 Ω impedance)

Measured portion: between terminals 4 and 6;
Ambient temperature: 25°C 77°F

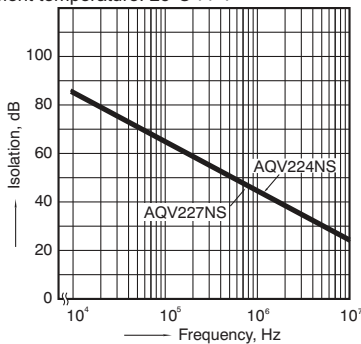

14.Insertion loss characteristics (50 Ω impedance)

Measured portion: between terminals 4 and 6;
Ambient temperature: 25°C 77°F

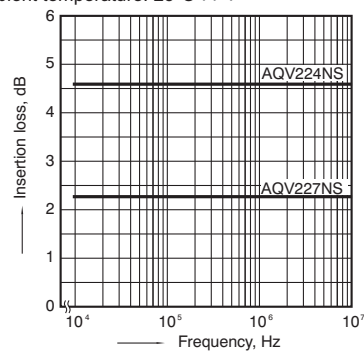

Panasonic

ideas for life



**DIP6-pin type featuring
low on-resistance with
200V/400V load voltage**

**PhotoMOS[®]
RF 1 Form A**
Low on-resistance (AQV22ON)

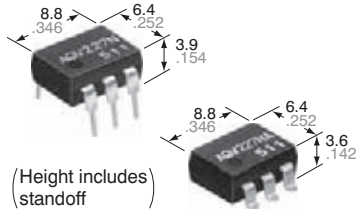

(Height includes
standoff)

CAD Data

mm inch

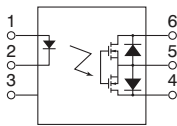

FEATURES

1. Low output capacitance and high response speed

The capacitance between output terminals is small; typ. 10pF. This enables a fast operation speed of typ. 0.2ms.

2. High sensitivity and low on-resistance

Max. 0.1 A of load current can be controlled with input current of 5 mA. The on resistance is less than our conventional models.

3. Low-level off state leakage current of typ. 0.03nA (AQV227N)

4. Controls low-level analog signals

TYPICAL APPLICATIONS

- Measuring instruments
- Communication equipment
- Computers
- Robots

PhotoMOS

TYPES

	Output rating*		Package	Part No.				Packing quantity	
				Through hole terminal	Surface-mount terminal		Tube	Tape and reel	
	Load voltage	Load current			Tube packing style	Tape and reel packing style			
AC/DC dual use	200 V	70 mA	DIP6-pin	AQV227N	AQV227NA	AQV227NAX	AQV227NAZ	1 tube contains: 50 pcs. 1 batch contains: 500 pcs.	1,000 pcs.
	400 V	50 mA		AQV224N	AQV224NA	AQV224NAX	AQV224NAZ		

*Indicate the peak AC and DC values.

Note: The surface mount terminal indicator "A" and the packing style indicator "X" or "Z" are not marked on the relay.

RATING

1. Absolute maximum ratings (Ambient temperature: 25°C 77°F)

Item		Symbol	Type of connection	AQV227N(A)	AQV224N(A)	Remarks
Input	LED forward current	I_F		50 mA		
	LED reverse voltage	V_R		5 V		
	Peak forward current	I_{FP}		1 A		f = 100 Hz, Duty factor = 0.1%
	Power dissipation	P_{in}		75 mW		
Output	Load voltage (peak AC)	V_L		200 V	400 V	
	Continuous load current	I_L	A	0.07 A	0.05 A	A connection: Peak AC, DC
			B	0.08 A	0.06 A	B, C connection: DC
			C	0.10 A	0.08 A	
	Peak load current	I_{peak}		0.21 A	0.15 A	A connection: 100 ms (1 shot), $V_L = DC$
	Power dissipation	P_{out}		360 mW		
Total power dissipation	P_T		410 mW			
I/O isolation voltage		V_{iso}		1,500 V AC		
Temperature limits	Operating	T_{opr}		-40°C to +85°C -40°F to +185°F		Non-condensing at low temperatures
	Storage	T_{stg}		-40°C to +100°C -40°F to +212°F		

RF 1 Form A Low on-resistance (AQV22ON)

2. Electrical characteristics (Ambient temperature: 25°C 77°F)

Item		Symbol	Type of connection	AQV227N(A)	AQV224N(A)	Remarks	
Input	LED operate current	Typical	I _{Fon}	0.9 mA		I _L = Max.	
		Maximum		3.0 mA			
	LED turn off current	Minimum	I _{Foff}	0.4 mA		I _L = Max.	
		Typical		0.85 mA			
LED dropout voltage	Typical	V _F	1.25 V (1.14 V at I _F = 5 mA)		I _F = 50 mA		
	Maximum		1.5 V				
Output	On resistance	Typical	R _{on}	A	30 Ω	70 Ω	I _F = 5 mA I _L = Max. Within 1 s on time
		Maximum		50 Ω	100 Ω		
		Typical	R _{on}	B	16 Ω	55 Ω	I _F = 5 mA I _L = Max. Within 1 s on time
		Maximum		25 Ω	70 Ω		
	Output capacitance	Typical	C _{out}	—	10 pF		I _F = 0 V _B = 0 f = 1 MHz
		Maximum			15 pF		
	Off state leakage current	Typical	I _{Leak}	—	0.03 nA	0.09 nA	I _F = 0 V _L = Max.
		Maximum			10 nA		
Transfer characteristics	Turn on time*	Typical	T _{on}	—	0.2 ms		I _F = 5 mA I _L = Max.
		Maximum			0.5 ms		
	Turn off time*	Typical	T _{off}	—	0.08 ms		I _F = 5 mA I _L = Max.
		Maximum			0.2 ms		
	I/O capacitance	Typical	C _{iso}	—	0.8 pF		f = 1 MHz V _B = 0
Maximum		1.5 pF					
Initial I/O isolation resistance	Minimum	R _{iso}	—	1,000 MΩ		500 V DC	

*Turn on/Turn off time

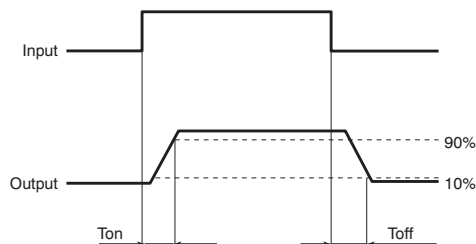

RECOMMENDED OPERATING CONDITIONS

Please obey the following conditions to ensure proper relay operation and resetting.

Item	Symbol	Recommended value	Unit
Input LED current	I _F	5	mA

■ For Dimensions, see page 60.

■ For Schematic and Wiring Diagrams, see page 65.

■ For Cautions for Use, see page 71.

■ These products are not designed for automotive use.

If you are considering to use these products for automotive applications, please contact your local Panasonic technical representative.

For more information, see page 80.

RF 1 Form A Low on-resistance (AQV22○N)

REFERENCE DATA

1. Load current vs. ambient temperature characteristics

Allowable ambient temperature: -40°C to $+85^{\circ}\text{C}$
 -40°F to $+185^{\circ}\text{F}$

Type of connection: A

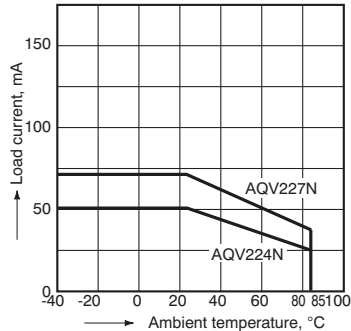

2. On resistance vs. ambient temperature characteristics

Measured portion: between terminals 4 and 6;
 LED current: 5 mA; Load voltage: Max. (DC);
 Continuous load current: Max. (DC)

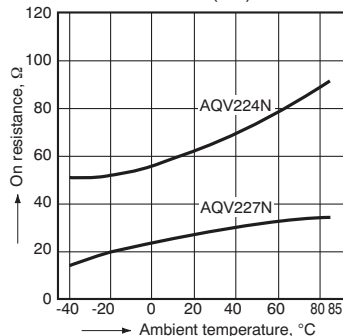

3. Turn on time vs. ambient temperature characteristics

Sample: AQV227N, AQV224N;
 LED current: 5 mA; Load voltage: Max. (DC);
 Continuous load current: Max. (DC)

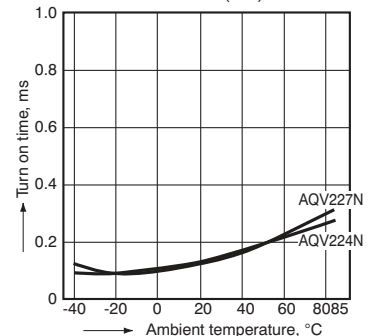

4. Turn off time vs. ambient temperature characteristics

Sample: AQV227N, AQV224N;
 LED current: 5 mA; Load voltage: Max. (DC);
 Continuous load current: Max. (DC)

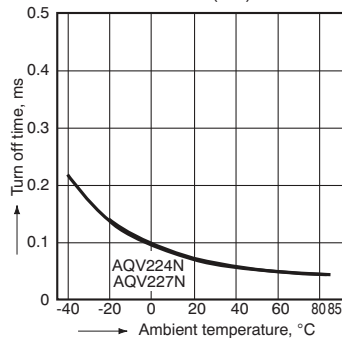

5. LED operate current vs. ambient temperature characteristics

Sample: AQV227N, AQV224N;
 Load voltage: Max. (DC);
 Continuous load current: Max. (DC)

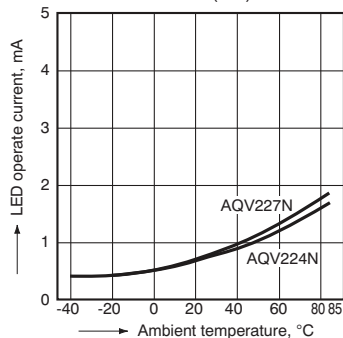

6. LED turn off current vs. ambient temperature characteristics

Sample: AQV227N, AQV224N;
 Load voltage: Max. (DC);
 Continuous load current: Max. (DC)

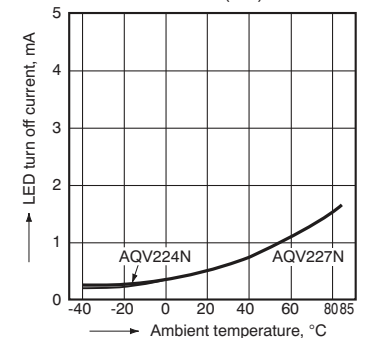

7. LED dropout voltage vs. ambient temperature characteristics

Sample: All types;
 LED current: 5 to 50 mA

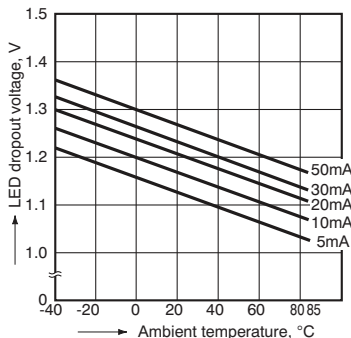

8. Current vs. voltage characteristics of output at MOS portion

Measured portion: between terminals 4 and 6;
 Ambient temperature: 25°C 77°F

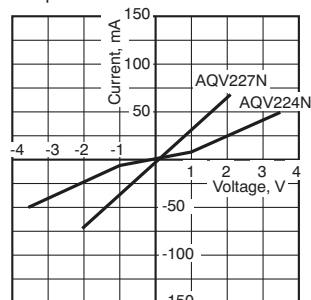

9. Off state leakage current

Sample: AQV227N, AQV224N;
 Measured portion: between terminals 4 and 6;
 Ambient temperature: 25°C 77°F

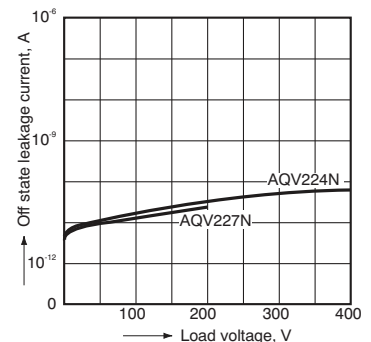

RF 1 Form A Low on-resistance (AQV22○N)

10. Turn on time vs. LED forward current characteristics

Sample: AQV227N, AQV224N;
Measured portion: between terminals 4 and 6;
Load voltage: Max. (DC);
Continuous load current: Max. (DC);
Ambient temperature: 25°C 77°F

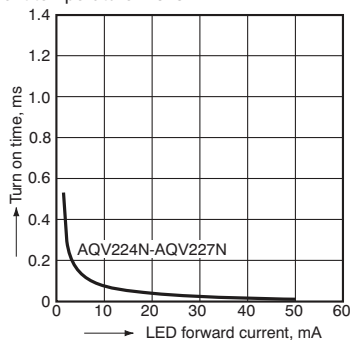

11. Turn off time vs. LED forward current characteristics

Sample: AQV227N, AQV224N;
Measured portion: between terminals 4 and 6;
Load voltage: Max. (DC);
Continuous load current: Max. (DC);
Ambient temperature: 25°C 77°F

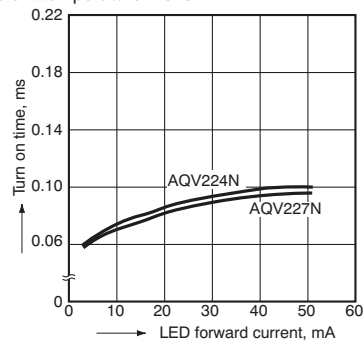

12. Output capacitance vs. applied voltage characteristics

Measured portion: between terminals 4 and 6;
Frequency: 1 MHz, 30 mVrms;
Ambient temperature: 25°C 77°F

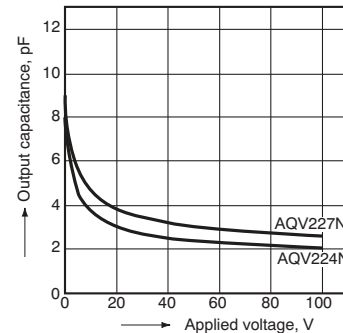

13. Isolation characteristics (50 Ω impedance)

Measured portion: between terminals 4 and 6;
Ambient temperature: 25°C 77°F

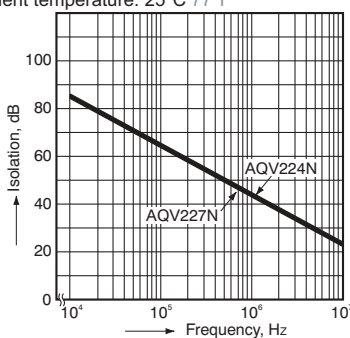

14. Insertion loss characteristics (50 Ω impedance)

Measured portion: between terminals 4 and 6;
Ambient temperature: 25°C 77°F

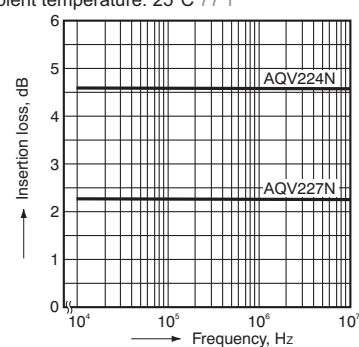

Panasonic

ideas for life



Miniature SOP8-pin type
featuring low on-resistance
with 200V load voltage

PhotoMOS[®]
RF SOP 2 Form A
Low on-resistance (AQW227NS)

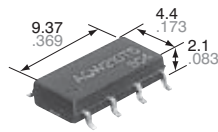

CAD Data

mm inch

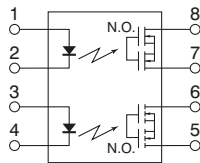

FEATURES

1. 2-channel (Form A) in SOP8-pin package miniature

(W) 4.4 × (L) 9.37 × (H) 2.1 mm (W) .173 × (L) .369 × (H) .083 inch —approx. 38% of the volume and 66% of the footprint size of DIP8-pin.

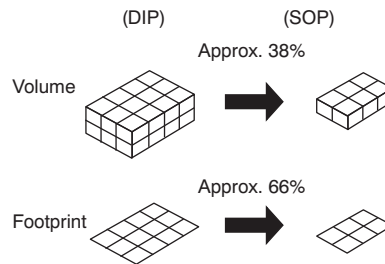

2. Low output capacitance and high response speed

The capacitance between output terminals is small; typ. 10pF.

This enables a fast operation speed of typ. 0.25ms.

3. Low-level off state leakage current

4. Controls low-level analog signals

TYPICAL APPLICATIONS

- Telephones
- Measuring instruments
- Computer input machines
- Industrial robots

PhotoMOS

TYPES

	Output rating*		Package	Part No.			Packing quantity	
	Load voltage	Load current		Tube packing style	Tape and reel packing style		Tube	Tape and reel
					Picked from the 1/2/3/4-pin side	Picked from the 5/6/7/8-pin side		
AC/DC dual use	200V	40mA	SOP8-pin	AQW227NS	AQW227NSX	AQW227NSZ	1 tube contains: 50 pcs. 1 batch contains: 1,000 pcs.	1,000 pcs.

* Indicate the peak AC and DC values.

Note: The packing style indicator "X" or "Z" is not marked on the relay.

RATING

1. Absolute maximum ratings (Ambient temperature: 25°C 77°F)

Item	Symbol	AQW227NS	Remarks	
Input	LED forward current	I_F	50 mA	
	LED reverse voltage	V_R	5 V	
	Peak forward current	I_{FP}	1 A	f = 100 Hz, Duty factor = 0.1%
	Power dissipation	P_{in}	75 mW	
Output	Load voltage (peak AC)	V_L	200 V	
	Continuous load current	I_L	0.04 A (0.05 A)	Peak AC, DC (): in case of using only 1 channel
	Peak load current	I_{peak}	0.15 A	100 ms (1 shot), $V_L = DC$
	Power dissipation	P_{out}	600 mW	
Total power dissipation	P_T	650 mW		
I/O isolation voltage	V_{iso}	1,500 V AC		
Temperature limits	Operating	T_{opr}	-40°C to +85°C -40°F to +185°F	Non-condensing at low temperatures
	Storage	T_{stg}	-40°C to +100°C -40°F to +212°F	

RF SOP 2 Form A Low on-resistance (AQW227NS)

2. Electrical characteristics (Ambient temperature: 25°C 77°F)

Item		Symbol	AQW227NS	Condition
Input	LED operate current	Typical	0.7mA	$I_L = \text{Max.}$
		Maximum	3.0mA	
	LED turn off current	Minimum	0.4mA	$I_L = \text{Max.}$
		Typical	0.65mA	
LED dropout voltage	Typical	1.25V (1.14V at $I_F = 5\text{mA}$)		$I_F = 50\text{mA}$
	Maximum	1.5V		
Output	On resistance	Typical	30Ω	$I_F = 5\text{mA}$ $I_L = \text{Max.}$ Within 1 s on time
		Maximum	50Ω	
	Output capacitance	Typical	10pF	$I_F = 0\text{mA}$ $V_B = 0\text{V}$ $f = 1\text{MHz}$
		Maximum	15pF	
Off state leakage current	Maximum	10nA	$I_F = 0\text{mA}$ $V_L = \text{Max.}$	
Transfer characteristics	Turn on time*	Typical	0.25ms	$I_F = 5\text{mA}$ $I_L = \text{Max.}$
		Maximum	0.5ms	
	Turn off time*	Typical	0.08ms	$I_F = 5\text{mA}$ $I_L = \text{Max.}$
		Maximum	0.2ms	
	I/O capacitance	Typical	0.8pF	$f = 1\text{MHz}$ $V_B = 0\text{V}$
		Maximum	1.5pF	
Initial I/O isolation resistance	Minimum	1,000MΩ	500V DC	

*Turn on/Turn off time

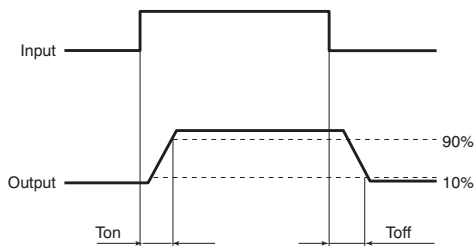

RECOMMENDED OPERATING CONDITIONS

Please obey the following conditions to ensure proper relay operation and resetting.

Item	Symbol	Recommended value	Unit
Input LED current	I_F	5	mA

■ For Dimensions, see page 61.

■ For Schematic and Wiring Diagrams, see page 65.

■ For Cautions for Use, see page 71.

■ These products are not designed for automotive use.

If you are considering to use these products for automotive applications, please contact your local Panasonic technical representative.

For more information, see page 80.

REFERENCE DATA

1. Load current vs. ambient temperature characteristics

Allowable ambient temperature: -40°C to +85°C
-40°F to +185°F

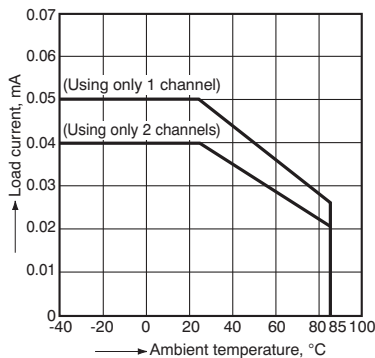

2. On resistance vs. ambient temperature characteristics

Measured portion: between terminals 5 and 6, 7 and 8:
LED current: 5 mA;
Load voltage: Max. (DC);
Continuous load current: Max. (DC)

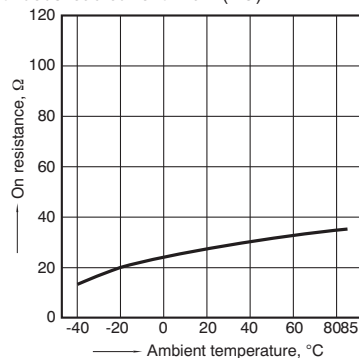

3. Turn on time vs. ambient temperature characteristics

LED current: 5 mA;
Load voltage: Max. (DC);
Continuous load current: Max. (DC)

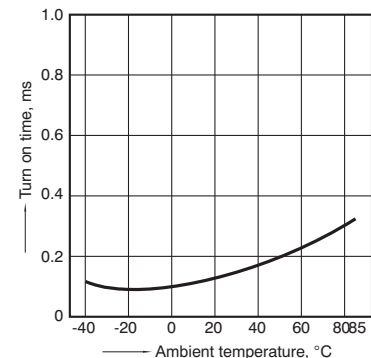

RF SOP 2 Form A Low on-resistance (AQW227NS)

4. Turn off time vs. ambient temperature characteristics

LED current: 5 mA; Load voltage: Max. (DC);
Continuous load current: Max. (DC)

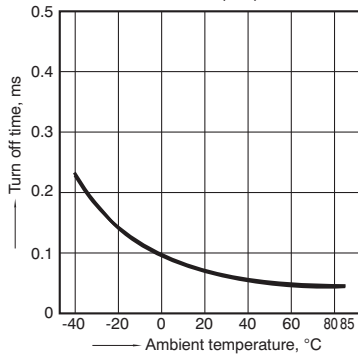

5. LED operate current vs. ambient temperature characteristics

Load voltage: Max. (DC);
Continuous load current: Max. (DC)

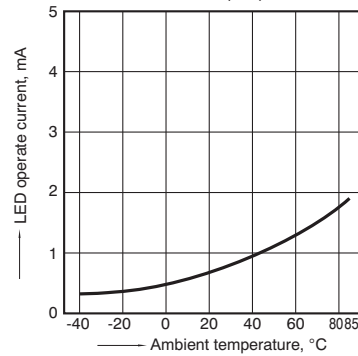

6. LED turn off current vs. ambient temperature characteristics

Load voltage: Max. (DC);
Continuous load current: Max. (DC)

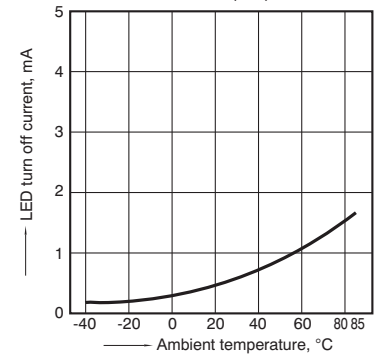

7. LED dropout voltage vs. ambient temperature characteristics

LED current: 5 to 50 mA

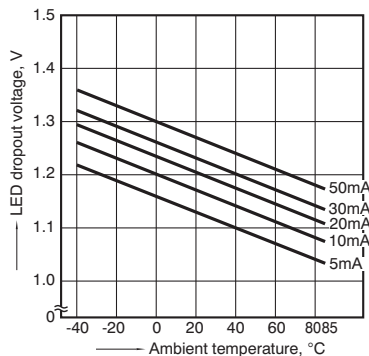

8. Current vs. voltage characteristics of output at MOS portion

Measured portion: between terminals 5 and 6,
7 and 8;
Ambient temperature: 25°C 77°F

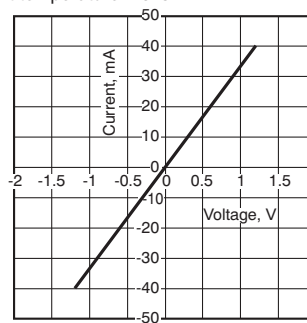

9. Off state leakage current vs. load voltage characteristics

Measured portion: between terminals 5 and 6,
7 and 8;
Ambient temperature: 25°C 77°F

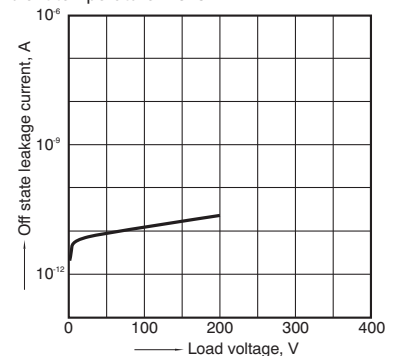

10. Turn on time vs. LED forward current characteristics

Measured portion: between terminals 5 and 6, 7 and 8;
Load voltage: Max. (DC);
Continuous load current: Max. (DC);
Ambient temperature: 25°C 77°F

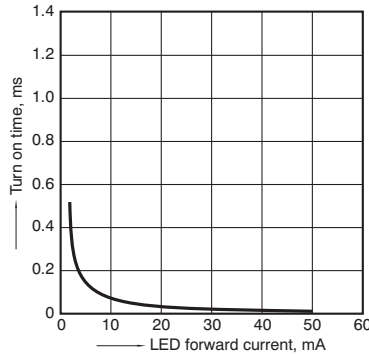

11. Turn off time vs. LED forward current characteristics

Measured portion: between terminals 5 and 6, 7 and 8;
Load voltage: Max. (DC);
Continuous load current: Max. (DC);
Ambient temperature: 25°C 77°F

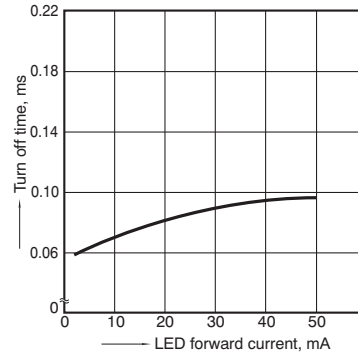

12. Output capacitance vs. applied voltage characteristics

Measured portion: between terminals 5 and 6, 7 and 8;
Frequency: 1 MHz, 30 mVrms;
Ambient temperature: 25°C 77°F

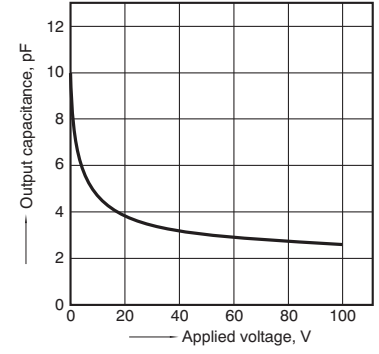

13. Isolation vs. frequency characteristics (50 Ω impedance)

Measured portion: between terminals 5 and 6,
7 and 8;
Ambient temperature: 25°C 77°F

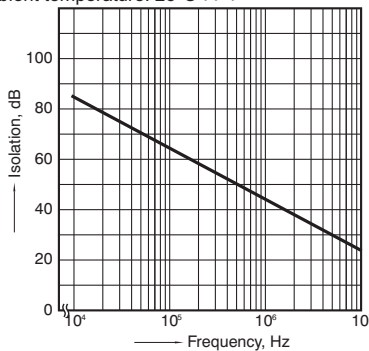

14. Insertion loss vs. frequency characteristics (50 Ω impedance)

Measured portion: between terminals 5 and 6,
7 and 8;
Ambient temperature: 25°C 77°F

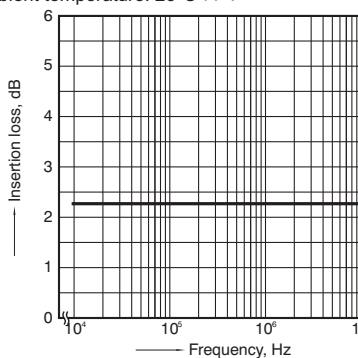

Panasonic

ideas for life

DIP8-pin type featuring
low on-resistance with
200V/400V load voltage

PhotoMOS[®]
RF 2 Form A
Low on-resistance (AQW22○N)

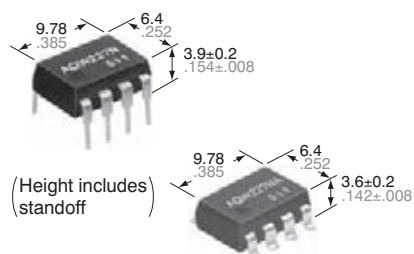

CAD Data

mm inch

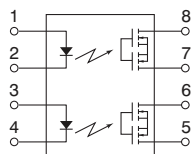

FEATURES

- 2-channels (Form A) type with high response speed, low leakage current and low on-resistance.**
- Applicable for 2 Form A use as well as two independent 1 Form A use**
- Low capacitance between output terminals ensures high response speed:**
The capacitance between output terminals is small; typ. 10 pF. This enables for a fast operation speed of typ. 0.2 ms.
- High sensitivity and low on-resistance:**
Max. 0.07 A of load current can be controlled with input current of 5 mA. The on-resistance is less than our conventional models.
- Low-level off state leakage current**
- Controls low-level analog signals:**
PhotoMOS relay features extremely low closed-circuit offset voltages to enable control of small analog signals without distortion.

TYPICAL APPLICATIONS

- Measuring instruments**
Scanner, IC checker, Board tester, etc.

TYPES

	Output rating*		Package	Part No.				Packing quantity	
				Through hole terminal	Surface-mount terminal		Tube	Tape and reel	
	Load voltage	Load current			Tube packing style	Tape and reel packing style			
AC/DC dual use	200 V	50 mA	DIP8-pin	AQW227N	AQW227NA	AQW227NAX	AQW227NAZ	1 tube contains: 50 pcs. 1 batch contains: 500 pcs.	1,000 pcs.
	400 V	40 mA		AQW224N	AQW224NA	AQW224NAX	AQW224NAZ		

*Indicate the peak AC and DC values.

Note: The surface mount terminal indicator "A" and the packing style indicator "X" or "Z" are not marked on the relay.

RATING

1. Absolute maximum ratings (Ambient temperature: 25°C 77°F)

Item		Symbol	AQW227N(A)	AQW224N(A)	Remarks
Input	LED forward current	I_F	50 mA		
	LED reverse voltage	V_R	5 V		
	Peak forward current	I_{FP}	1 A		$f = 100 \text{ Hz}$, Duty factor = 0.1%
	Power dissipation	P_{in}	75 mW		
Output	Load voltage (peak AC)	V_L	200 V	400 V	
	Continuous load current	I_L	0.05 A (0.07 A)	0.04 A (0.05 A)	Peak AC, DC (): in case of using only 1 channel
	Peak load current	I_{peak}	0.15 A	0.12 A	A connection: 100 ms (1 shot), $V_L = \text{DC}$
	Power dissipation	P_{out}	800 mW		
Total power dissipation		P_T	850 mW		
I/O isolation voltage		V_{iso}	1,500 V AC		
Temperature limits	Operating	T_{opr}	-40°C to +85°C -40°F to +185°F		Non-condensing at low temperatures
	Storage	T_{stg}	-40°C to +100°C -40°F to +212°F		

RF 2 Form A Low on-resistance (AQW220N)

2. Electrical characteristics (Ambient temperature: 25°C 77°F)

Item			Symbol	AQW227N(A)	AQW224N(A)	Remarks
Input	LED operate current	Typical	I _{Fon}	0.9 mA		I _L = Max.
		Maximum		3.0 mA		
	LED turn off current	Minimum	I _{Foff}	0.4 mA		I _L = Max.
		Typical		0.8 mA		
	LED dropout voltage	Typical	V _F	1.25 V (1.14 V at I _F = 5 mA)		I _F = 50 mA
		Maximum		1.5 V		
Output	On resistance	Typical	R _{on}	30 Ω	70 Ω	I _F = 5 mA I _L = Max. Within 1 s on time
		Maximum		50 Ω	100 Ω	
	Output capacitance	Typical	C _{out}	10 pF		I _F = 0 V _B = 0 f = 1 MHz
		Maximum		15 pF		
	Off state leakage current	Maximum	I _{Leak}	10 nA		I _F = 0 V _L = Max.
	Transfer characteristics	Turn on time*	Typical	T _{on}	0.2 ms	
Maximum			0.5 ms			
Turn off time*		Typical	T _{off}	0.08 ms		I _F = 5 mA I _L = Max.
		Maximum		0.2 ms		
I/O capacitance		Typical	C _{iso}	0.8 pF		f = 1 MHz V _B = 0
		Maximum		1.5 pF		
Initial I/O isolation resistance	Minimum	R _{iso}	1,000 MΩ		500 V DC	

*Turn on/Turn off time

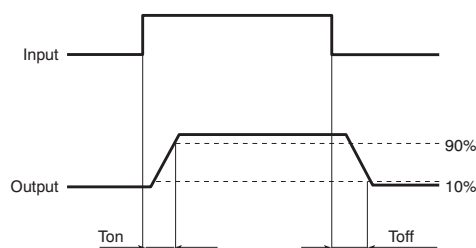

RECOMMENDED OPERATING CONDITIONS

Please obey the following conditions to ensure proper relay operation and resetting.

Item	Symbol	Recommended value	Unit
Input LED current	I _F	5	mA

■ For Dimensions, see page 61.

■ For Schematic and Wiring Diagrams, see page 65.

■ For Cautions for Use, see page 71.

■ These products are not designed for automotive use.

If you are considering to use these products for automotive applications, please contact your local Panasonic technical representative.

For more information, see page 80.

REFERENCE DATA

1. Load current vs. ambient temperature characteristics

Allowable ambient temperature: -40°C to +85°C
-40°F to +185°F

When using 2 channels

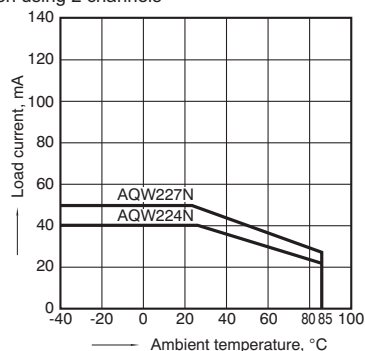

2. On resistance vs. ambient temperature characteristics

Measured portion: between terminals 5 and 6,
7 and 8; LED current: 5 mA; Load voltage: Max. (DC);
Continuous load current: Max. (DC)

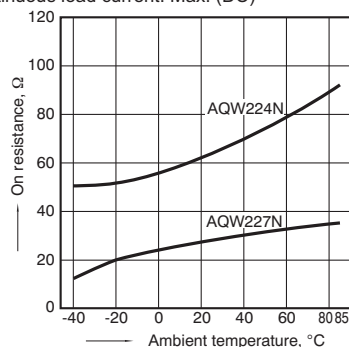

3. Turn on time vs. ambient temperature characteristics

LED current: 5 mA; Load voltage: Max. (DC);
Continuous load current: Max. (DC)

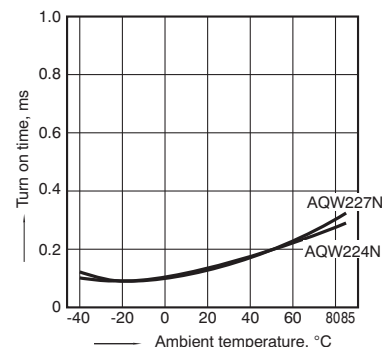

RF 2 Form A Low on-resistance (AQW220N)

4. Turn off time vs. ambient temperature characteristics

LED current: 5 mA; Load voltage: Max. (DC);
Continuous load current: Max. (DC)

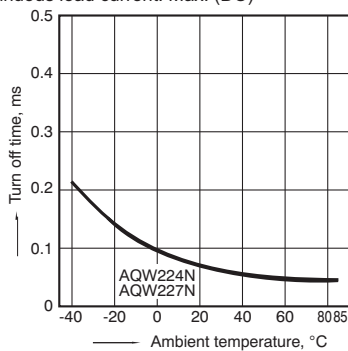

5. LED operate current vs. ambient temperature characteristics

Load voltage: Max. (DC);
Continuous load current: Max. (DC)

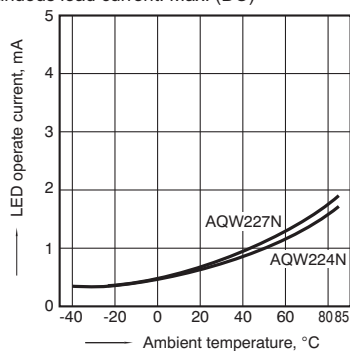

6. LED turn off current vs. ambient temperature characteristics

Load voltage: Max. (DC);
Continuous load current: Max. (DC)

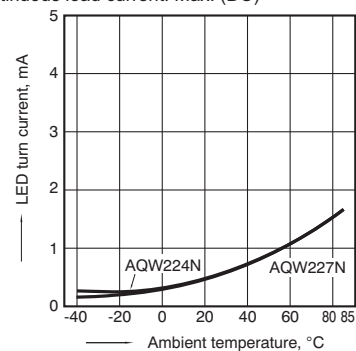

7. LED dropout voltage vs. ambient temperature characteristics

Sample: All types;
LED current: 5 to 50 mA

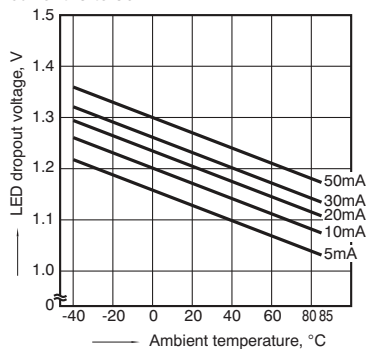

8. Voltage vs. current characteristics of output at MOS portion

Measured portion: between terminals 5 and 6,
7 and 8; Ambient temperature: 25°C 77°F

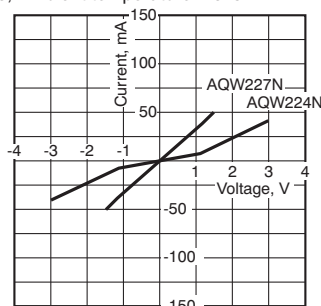

9. Off state leakage current

Measured portion: between terminals 5 and 6,
7 and 8;
Ambient temperature: 25°C 77°F

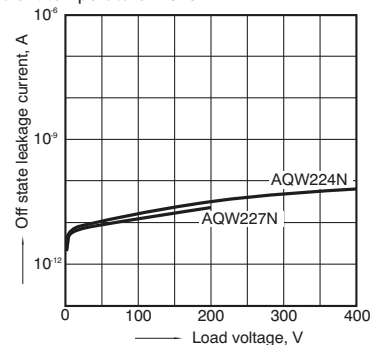

10. LED forward current vs. turn on time characteristics

Measured portion: between terminals 5 and 6,
7 and 8; Load voltage: Max. (DC);
Continuous load current: Max. (DC);
Ambient temperature: 25°C 77°F

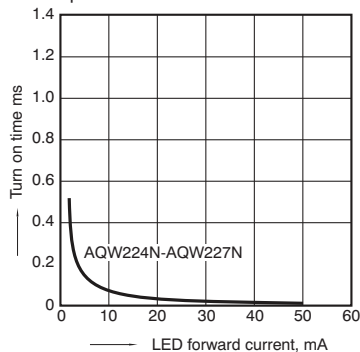

11. LED forward current vs. turn off time characteristics

Measured portion: between terminals 5 and 6,
7 and 8; Load voltage: Max. (DC);
Continuous load current: Max. (DC);
Ambient temperature: 25°C 77°F

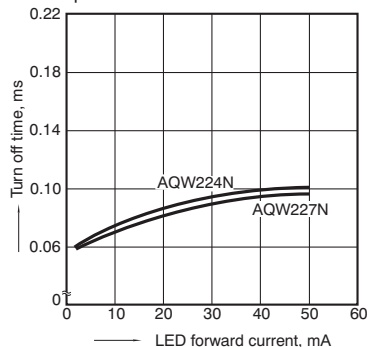

12. Applied voltage vs. output capacitance characteristics

Measured portion: between terminals 5 and 6,
7 and 8; Frequency: 1 MHz, 30 mVrms;
Ambient temperature: 25°C 77°F

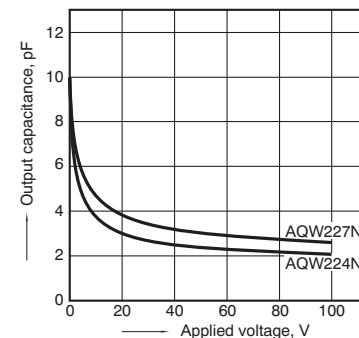

13. Isolation characteristics (50 Ω impedance)

Measured portion: between terminals 5 and 6,
7 and 8;
Ambient temperature: 25°C 77°F

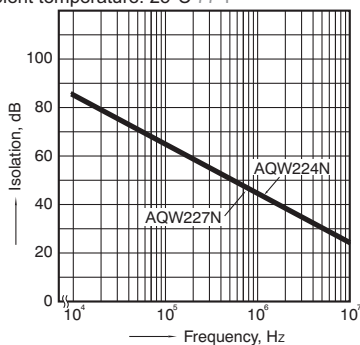

14. Insertion loss characteristics (50 Ω impedance)

Measured portion: between terminals 5 and 6,
7 and 8;
Ambient temperature: 25°C 77°F

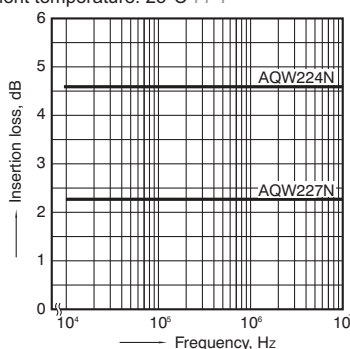

Panasonic

ideas for life

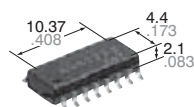

CAD Data

mm inch

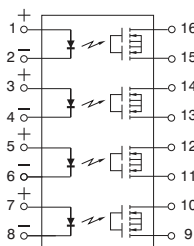

**Space-saving
SOP16-pin type
featuring low on-resistance
with 80V load voltage**

**PhotoMOS®
RF SOP 4 Form A**
Low on-resistance (AQS225R2S)

FEATURES

1. 4-channel (4 Form A) in a small SOP16-pin package

The device comes in a miniature SOP measuring (W) 10.37 × (L) 4.4 × (H) 2.1mm (W) .408 × (L) .173 × (H) .083inch— approx. 50% of the footprint size of 8-pin (2-channel) type.

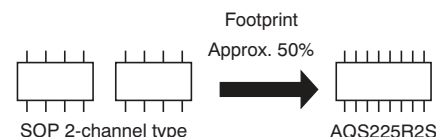

2. Low C×R and high response speed

- Output capacitance: 4.5pF (typ.)
- On resistance: 10.5Ω (typ.)
- Turn on time: 0.04ms (typ.)

3. Applicable for 4 Form A use, as well as 4 independent 1 Form A

4. Low-level off state leakage current of typ. 0.01nA

5. Controls low-level analog signals

TYPICAL APPLICATIONS

For multi-circuit switching;

- 1. Measuring and testing equipment**
IC tester, Liquid crystal driver tester, Probe card, Bare board tester, In-circuit tester, Function tester, etc.
- 2. Communication and broadcasting equipment**
- 3. Medical equipment**
Ultrasonic wave diagnostic machine
- 4. Multi-point recorder**
Warping, Thermo couple

PhotoMOS

TYPES

	Output rating*		Package	Part No.			Packing quantity	
	Load voltage	Load current		Tube packing style	Tape and reel packing style		Tube	Tape and reel
					Picked from the 1/2/3/4/5/6/7/8-pin side	Picked from the 9/10/11/12/13/14/15/16-pin side		
AC/DC dual use	80V	70mA	SOP16-pin	AQS225R2S	AQS225R2SX	AQS225R2SZ	1 tube contains: 50 pcs. 1 batch contains: 1,000 pcs.	1,000 pcs.

* Indicate the peak AC and DC values.

Notes: 1. The packing style indicator "X" or "Z" is not marked on the relay.

2. For types with a built-in resistor, see page 213.

RATING

1. Absolute maximum ratings (Ambient temperature: 25°C 77°F)

Item		Symbol	AQS225R2S	Remarks
Input	LED forward current	I _F	50 mA	
	LED reverse voltage	V _R	5 V	
	Peak forward current	I _{FP}	1 A	f = 100 Hz, Duty factor = 0.1%
	Power dissipation	P _{in}	75 mW	
Output	Load voltage (peak AC)	V _L	80 V	
	Continuous load current	I _L	0.07 A	Peak AC, DC
	Peak load current	I _{peak}	0.2 A	100 ms (1 shot), V _L = DC
	Power dissipation	P _{out}	600 mW	
Total power dissipation		P _T	650 mW	
I/O isolation voltage		V _{iso}	1,500 V AC	
Temperature limits	Operating	T _{opr}	-40°C to +85°C -40°F to +185°F	Non-condensing at low temperatures
	Storage	T _{stg}	-40°C to +100°C -40°F to +212°F	

RF SOP 4 Form A Low on-resistance (AQS225R2S)

2. Electrical characteristics (Ambient temperature: 25°C 77°F)

Item		Symbol	AQS225R2S	Condition
Input	LED operate current	Typical	0.9 mA	$I_L = \text{Max.}$
		Maximum	3 mA	
	LED turn off current	Minimum	0.3 mA	$I_L = \text{Max.}$
		Typical	0.85 mA	
LED dropout voltage	Typical	V_F	1.25 V (1.14 V at $I_F = 5 \text{ mA}$)	$I_F = 50 \text{ mA}$
	Maximum		1.5 V	
Output	On resistance	Typical	10.5 Ω	$I_F = 5 \text{ mA}$ $I_L = \text{Max.}$ Within 1 s on time
		Maximum	15 Ω	
	Output capacitance	Typical	4.5 pF	$I_F = 0$ $V_B = 0 \text{ V}$ $f = 1 \text{ MHz}$
		Maximum	6 pF	
	Off state leakage current	Typical	0.01 nA	$I_F = 0$ $V_L = \text{Max.}$
Maximum		10 nA		
Transfer characteristics	Turn on time*	Typical	0.04 ms	$I_F = 5 \text{ mA}$ $I_L = \text{Max.}$
		Maximum	0.3 ms	
	Turn off time*	Typical	0.07 ms	$I_F = 5 \text{ mA}$ $I_L = \text{Max.}$
		Maximum	0.2 ms	
	I/O capacitance	Typical	0.8 pF	$f = 1 \text{ MHz}$ $V_B = 0$
Maximum		1.5 pF		
Initial I/O isolation resistance	Minimum	R_{iso}	1,000 M Ω	500 V DC

*Turn on/Turn off time

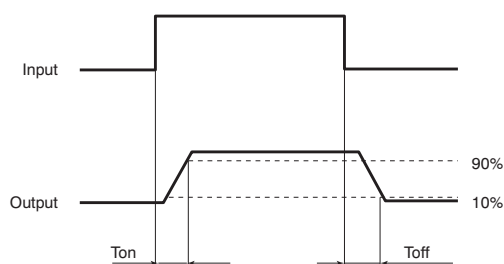

RECOMMENDED OPERATING CONDITIONS

Please obey the following conditions to ensure proper relay operation and resetting.

Item	Symbol	Recommended value	Unit
Input LED current	I_F	5	mA

■ For Dimensions, see page 62.

■ For Schematic and Wiring Diagrams, see page 67.

■ For Cautions for Use, see page 71.

■ These products are not designed for automotive use.

If you are considering to use these products for automotive applications, please contact your local Panasonic technical representative.

For more information, see page 80.

REFERENCE DATA

1. Load current vs. ambient temperature characteristics

Allowable ambient temperature: -40°C to +85°C
-40°F to +185°F

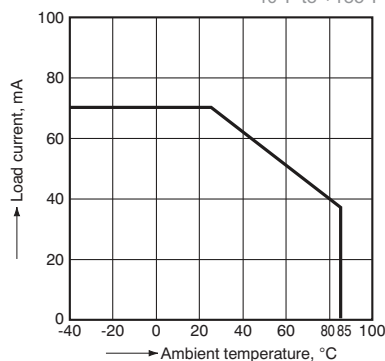

2. On resistance vs. ambient temperature characteristics

LED current: 5 mA;
Continuous load current: 70 mA (DC)

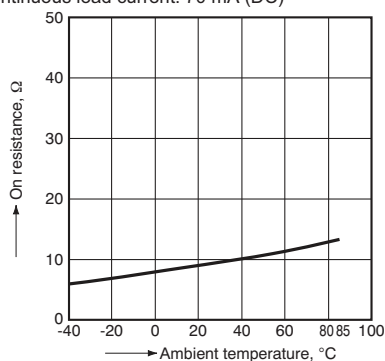

3. Turn on time vs. ambient temperature characteristics

LED current: 5 mA; Load voltage: 80 V (DC);
Continuous load current: 70 mA (DC)

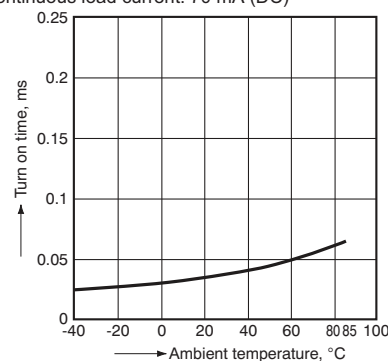

RF SOP 4 Form A Low on-resistance (AQS225R2S)

4. Turn off time vs. ambient temperature characteristics

LED current: 5 mA; Load voltage: 80 V (DC);
Continuous load current: 70 mA (DC)

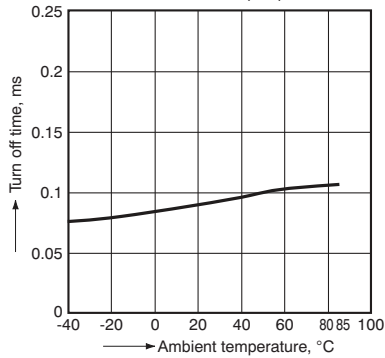

5. LED operate current vs. ambient temperature characteristics

Continuous load current: 70 mA (DC)

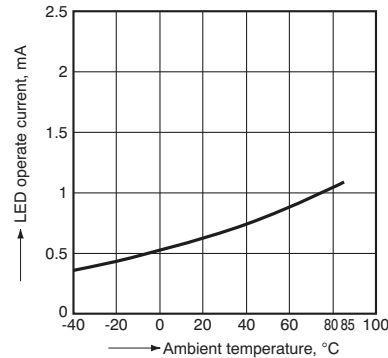

6. LED turn off current vs. ambient temperature characteristics

Continuous load current: 70 mA (DC)

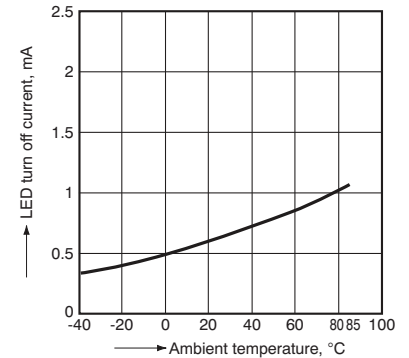

7. LED dropout voltage vs. ambient temperature characteristics

LED current: 5 to 50 mA

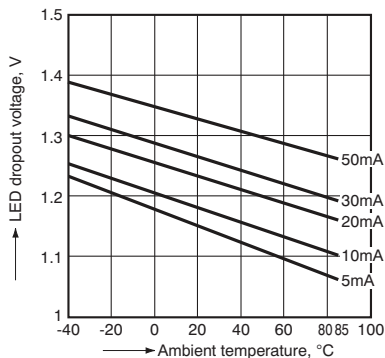

8. Current vs. voltage characteristics of output at MOS portion

Ambient temperature: 25°C 77°F

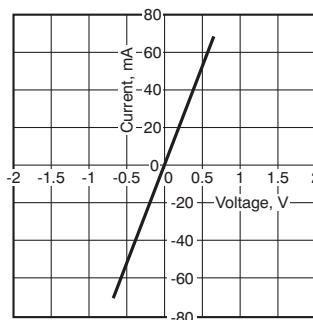

9. Off state leakage current vs. load voltage characteristics

Ambient temperature: 25°C 77°F

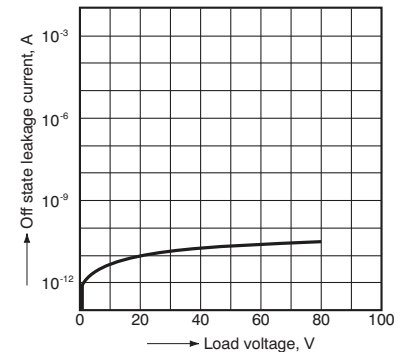

10. Turn on time vs. LED forward current characteristics

Load voltage: 80 V (DC); Continuous load current:
70 mA (DC); Ambient temperature: 25°C 77°F

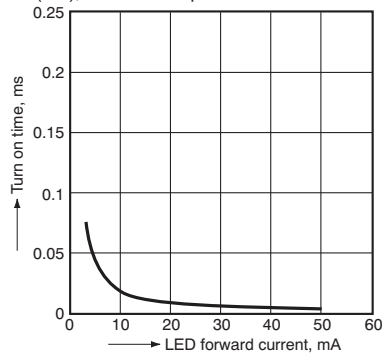

11. Turn off time vs. LED forward current characteristics

Load voltage: 80 V (DC); Continuous load current:
70 mA (DC); Ambient temperature: 25°C 77°F

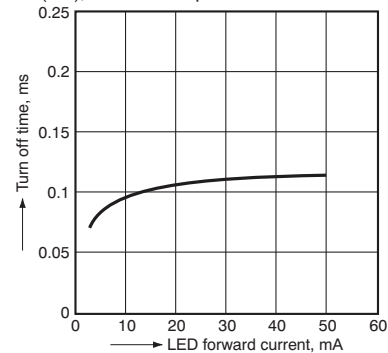

12. Output capacitance vs. applied voltage characteristics

Frequency: 1 MHz, 30 mVrms;
Ambient temperature: 25°C 77°F

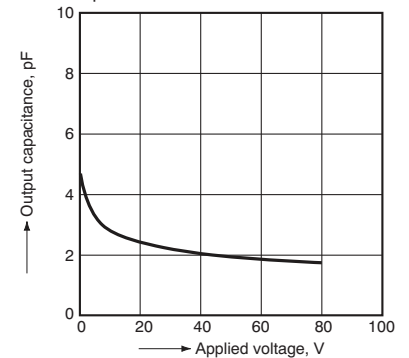

13. Isolation vs. frequency characteristics (50Ω impedance)

Ambient temperature: 25°C 77°F

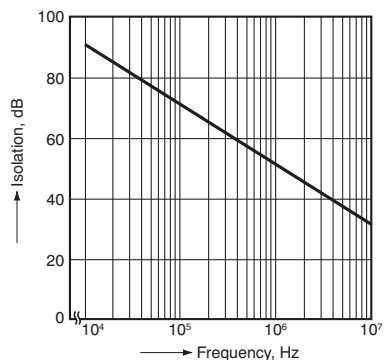

14. Insertion loss vs. frequency characteristics (50Ω impedance)

Ambient temperature: 25°C 77°F

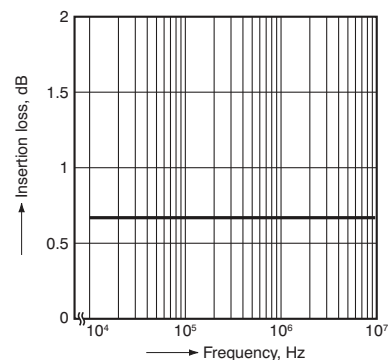

Panasonic

ideas for life

 (Standard type)
 
 (Reinforced type)

**DIP6-pin type
with low on-resistance
and high cost-performance**

**PhotoMOS[®]
HE 1 Form A
(AQV250)**

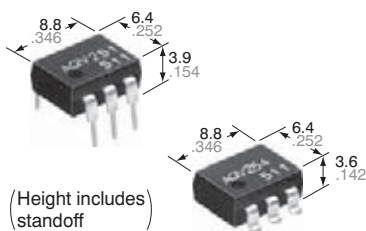

CAD Data

mm inch

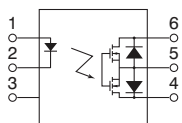

FEATURES

1. Low on-resistance of typ. 0.6Ω (AQV251)
2. Reinforced insulation type of 5,000V I/O isolation available
3. Wide variation of 40V to 1,500V load voltage

TYPICAL APPLICATIONS

- High-speed inspection machines
- Telephone equipment
- Data communication equipment

TYPES

	I/O isolation	Output rating*		Package	Part No.				Packing quantity	
					Through hole terminal	Surface-mount terminal			Tube	Tape and reel
						Tube packing style	Tape and reel packing style			
							Picked from the 1/2/3-pin side	Picked from the 4/5/6-pin side		
AC/DC dual use	1,500V	40 V	500 mA	DIP6-pin	AQV251	AQV251A	AQV251AX	AQV251AZ	1 tube contains: 50 pcs. 1 batch contains: 500 pcs.	1,000 pcs.
		60 V	400 mA		AQV252	AQV252A	AQV252AX	AQV252AZ		
		100 V	350 mA		AQV255	AQV255A	AQV255AX	AQV255AZ		
		200 V	250 mA		AQV257	AQV257A	AQV257AX	AQV257AZ		
		250 V	200 mA		AQV253	AQV253A	AQV253AX	AQV253AZ		
		400 V	150 mA		AQV254	AQV254A	AQV254AX	AQV254AZ		
		1,000 V	30 mA		AQV259	AQV259A	AQV259AX	AQV259AZ		
		1,500 V	20 mA		AQV258	AQV258A	AQV258AX	AQV258AZ		
	Reinforced 5,000V	250 V	200 mA		AQV253H	AQV253HA	AQV253HAX	AQV253HAZ		
		400 V	150 mA		AQV254H	AQV254HA	AQV254HAX	AQV254HAZ		

*Indicate the peak AC and DC values.

Note: The surface mount terminal indicator "A" and the packing style indicator "X" or "Z" are not marked on the relay.

RATING

1. Absolute maximum ratings (Ambient temperature: 25°C 77°F)

Item	Symbol	Type of connection	AQV251(A)	AQV252(A)	AQV255(A)	AQV257(A)	AQV253(A)	AQV254(A)	AQV259(A)	AQV258(A)	AQV253H(A)	AQV254H(A)	Remarks	
			Input	LED forward current	I _F	50 mA								
	LED reverse voltage	V _R	5 V											
	Peak forward current	I _{FP}	1 A										f = 100 Hz, Duty factor +0.1%	
	Power dissipation	P _{in}	75 mW											
Output	Load voltage (peak AC)	V _L	40 V	60 V	100 V	200 V	250 V	400 V	1,000 V	1,500 V	250 V	400 V		
	Continuous load current	I _L	A	0.5 A	0.4 A	0.35 A	0.25 A	0.2 A	0.15 A	0.03 A	0.02 A	0.2 A	0.15 A	A connection: Peak AC, DC
			B	0.7 A	0.6 A	0.45 A	0.35 A	0.3 A	0.18 A	0.04 A	0.025 A	0.3 A	0.18 A	B, C connection: DC
			C	1.0 A	0.8 A	0.70 A	0.5 A	0.4 A	0.25 A	0.05 A	0.04 A	0.4 A	0.25 A	
	Peak load current	I _{peak}	1.8 A	1.5 A	1.0 A	0.75 A	0.6 A	0.5 A	0.09 A	0.06 A	0.6 A	0.5 A	A connection: 100 ms (1 shot) V _L = DC	
Power dissipation	P _{out}	360 mW												
Total power dissipation	P _T	410 mW												
I/O isolation voltage	V _{iso}	1,500 V AC					5,000 V AC							
Temperature limits	Operating	T _{opr}	-40°C to +85°C -40°F to +185°F										Non-condensing at low temperatures	
	Storage	T _{stg}	-40°C to +100°C -40°F to +212°F											

HE 1 Form A (AQV25○)

2. Electrical characteristics (Ambient temperature: 25°C 77°F)

Item		Symbol	Type of connection	AQV251(A)	AQV252(A)	AQV255(A)	AQV257(A)	AQV253(A)	AQV254(A)	AQV259(A)	AQV258(A)	AQV253H(A)	AQV254H(A)	Condition		
Input	LED operate current	Typical	I _{Fon}	0.9 mA								1.4 mA		I _L = Max.		
		Maximum		3 mA												
	LED turn off current	Minimum	I _{Foff}	0.4 mA												I _L = Max.
Typical		0.8 mA								1.3 mA						
LED dropout voltage	Typical	V _F	—	1.25 V (1.14 V at I _F = 5 mA)												I _F = 50 mA
	Maximum			1.5 V												
Output	On resistance	Typical	R _{on}	A	0.6 Ω	0.74 Ω	1.8 Ω	2.6 Ω	5.5 Ω	12.4 Ω	85 Ω	345 Ω	5.5 Ω	12.4 Ω	I _F = 5 mA I _L = Max. Within 1 s on time	
		Maximum			1 Ω	1.4 Ω	2.5 Ω	4 Ω	8 Ω	16 Ω	200 Ω	500 Ω	8 Ω	16 Ω		
	On resistance	Typical	R _{on}	B	0.3Ω	0.37 Ω	0.9 Ω	1.4 Ω	2.7 Ω	6.2 Ω	60 Ω	345 Ω	2.7 Ω	6.2 Ω	I _F = 5 mA I _L = Max. Within 1 s on time	
		Maximum			0.5 Ω	0.7 Ω	1.25 Ω	2 Ω	4 Ω	8 Ω	100 Ω	500 Ω	4 Ω	8 Ω		
	On resistance	Typical	R _{on}	C	0.15 Ω	0.18 Ω	0.45 Ω	0.7 Ω	1.4 Ω	3.1 Ω	30 Ω	160 Ω	1.4 Ω	3.1 Ω	I _F = 5 mA I _L = Max. Within 1 s on time	
		Maximum			0.25 Ω	0.35 Ω	0.63 Ω	1 Ω	2 Ω	4 Ω	50 Ω	250 Ω	2 Ω	4 Ω		
Off state leakage current	Maximum	I _{Leak}	—	1 μA						10 μA		1 μA		I _F = 0 mA V _L = Max.		
Transfer characteristics	Turn on time*	Typical	T _{on}	1.7 ms	1.4 ms	0.9 ms	1.5 ms	0.8ms	0.8ms	0.6ms	0.35 ms	2.4ms	1.8ms	I _F = 5 mA I _L = Max.		
		Maximum		3 ms		2 ms	3 ms	2 ms		1 ms		4 ms	3 ms			
	Turn off time*	Typical	T _{off}	—	0.07 ms		0.09 ms	0.1 ms	0.06 ms	0.05 ms	0.04 ms		0.06 ms	0.05 ms	I _F = 5 mA I _L = Max.	
Maximum		0.2 ms														
I/O capacitance	Typical	C _{iso}	—	1.3 pF												f = 1 MHz V _B = 0 V
	Maximum			3 pF												
Initial I/O isolation resistance	Minimum	R _{iso}	—	1,000 MΩ												500 V DC

*Turn on/Turn off time

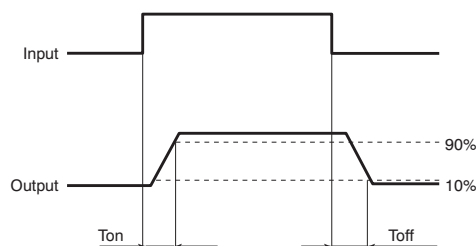

RECOMMENDED OPERATING CONDITIONS

Please obey the following conditions to ensure proper relay operation and resetting.

Item	Symbol	Recommended value	Unit
Input LED current	I _F	Standard type: 5 Reinforced insulation type: 5 to 10	mA

■ For Dimensions, see page 60.

■ For Schematic and Wiring Diagrams, see page 65.

■ For Cautions for Use, see page 71.

■ These products are not designed for automotive use.

If you are considering to use these products for automotive applications, please contact your local Panasonic technical representative.

For more information, see page 80.

HE 1 Form A (AQV25○)

REFERENCE DATA

1-(1) Load current vs. ambient temperature characteristics

Allowable ambient temperature: -40°C to $+85^{\circ}\text{C}$
 -40°F to $+185^{\circ}\text{F}$;

Type of connection: A

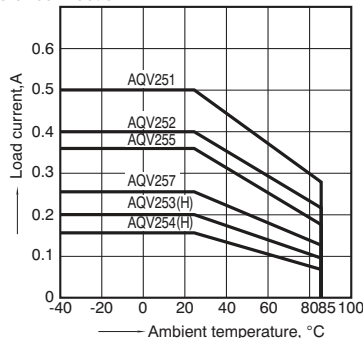

1-(2) Load current vs. ambient temperature characteristics

Allowable ambient temperature: -40°C to $+85^{\circ}\text{C}$
 -40°F to $+185^{\circ}\text{F}$;

Type of connection: A

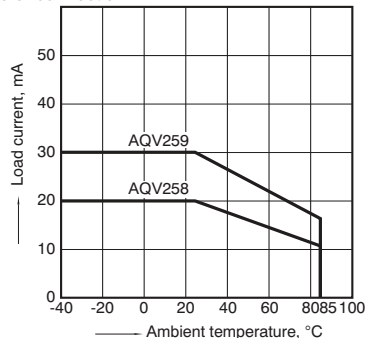

2-(1) On resistance vs. ambient temperature characteristics

Measured portion: between terminals 4 and 6;
 LED current: 5 mA;
 Continuous load current: Max. (DC)

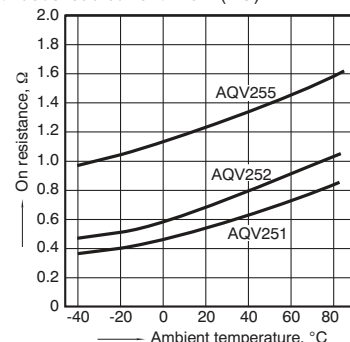

2-(2) On resistance vs. ambient temperature characteristics

Measured portion: between terminals 4 and 6;
 LED current: 5 mA;
 Continuous load current: Max. (DC)

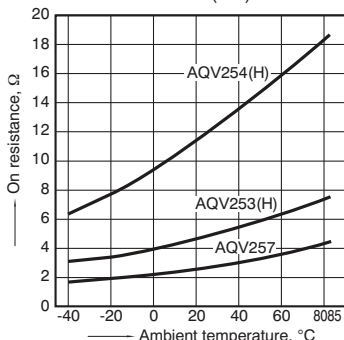

2-(3) On resistance vs. ambient temperature characteristics

Measured portion: between terminals 4 and 6;
 LED current: 5 mA;
 Continuous load current: 30 mA (DC)

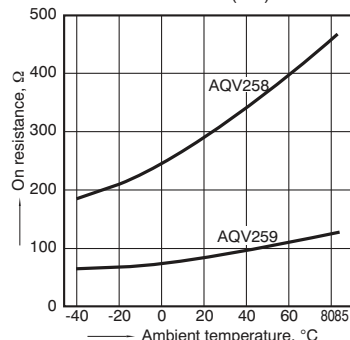

3-(1) Turn on time vs. ambient temperature characteristics

LED current: 5 mA;
 Load voltage: Max. (DC);
 Continuous load current: Max. (DC)

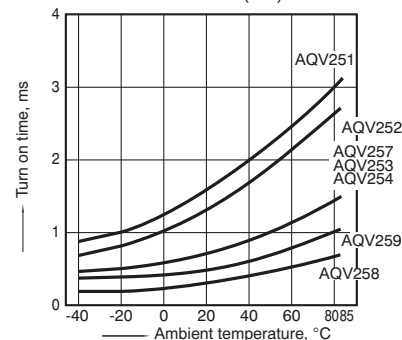

3-(2) Turn on time vs. ambient temperature characteristics

LED current: 5 mA; Load voltage: Max. (DC);
 Continuous load current: Max. (DC)

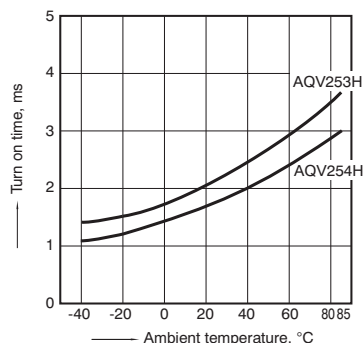

4-(1) Turn off time vs. ambient temperature characteristics

LED current: 5 mA; Load voltage: Max. (DC);
 Continuous load current: Max. (DC)

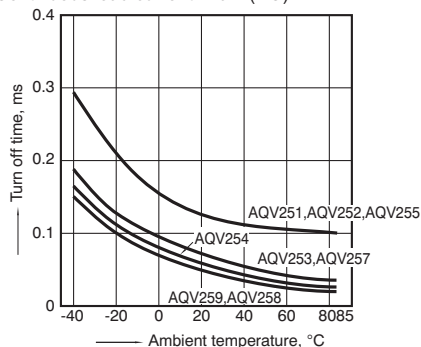

4-(2) Turn off time vs. ambient temperature characteristics

Sample: AQV253H, AQV254H
 LED current: 5 mA; Load voltage: Max. (DC);
 Continuous load current: Max. (DC)

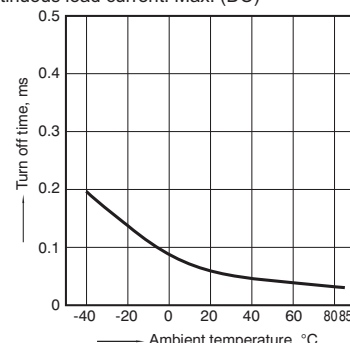

5-(1) LED operate current vs. ambient temperature characteristics

Sample: AQV251, AQV252, AQV253, AQV254, AQV259;
 Load voltage: Max. (DC);
 Continuous load current: Max. (DC)

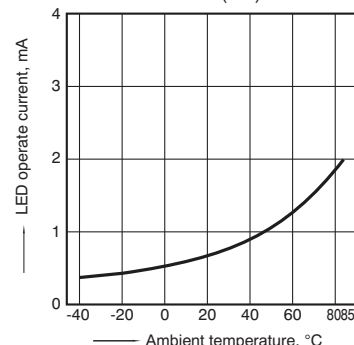

5-(2) LED operate current vs. ambient temperature characteristics

Sample: AQV253H, AQV254H;
 Load voltage: Max. (DC);
 Continuous load current: Max. (DC)

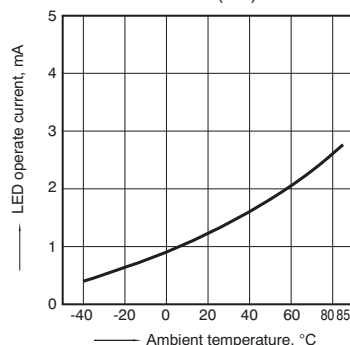

6-(1) LED turn off current vs. ambient temperature characteristics

Sample: AQV251, AQV252, AQV253, AQV254, AQV259;
 Load voltage: Max. (DC);
 Continuous load current: Max. (DC)

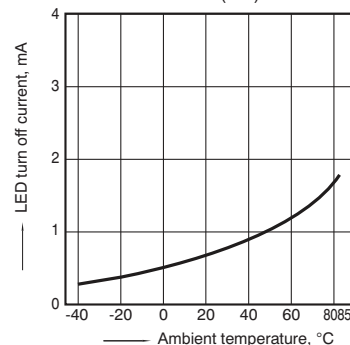

HE 1 Form A (AQV25○)

6.-(2) LED turn off current vs. ambient temperature characteristics

Sample: AQV251, AQV252, AQV253, AQV254, AQV259; Load voltage: Max. (DC); Continuous load current: Max. (DC)

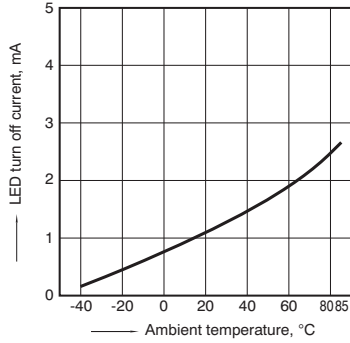

7. LED dropout voltage vs. ambient temperature characteristics

LED current: 5 to 50 mA

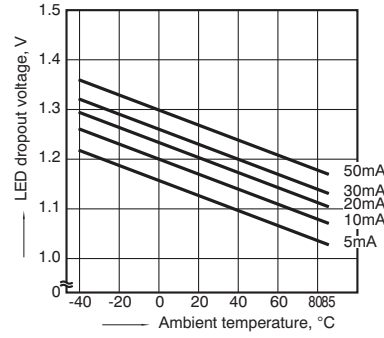

8.-(1) Current vs. voltage characteristics of output at MOS portion

Measured portion: between terminals 4 and 6; Ambient temperature: 25°C 77°F

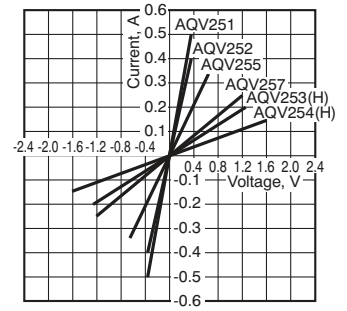

8.-(2) Current vs. voltage characteristics of output at MOS portion

Sample: AQV259; Measured portion: between terminals 4 and 6; Ambient temperature: 25°C 77°F

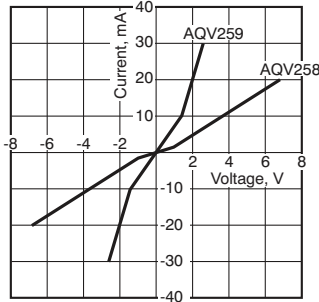

9.-(1) Off state leakage current vs. load voltage characteristics

Sample: AQV259; Measured portion: between terminals 4 and 6; Ambient temperature: 25°C 77°F

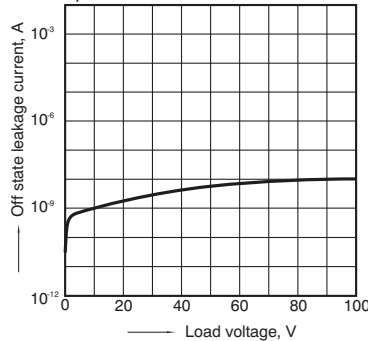

9.-(2) Off state leakage current vs. load voltage characteristics

Sample: AQV254H; Measured portion: between terminals 4 and 6; Ambient temperature: 25°C 77°F

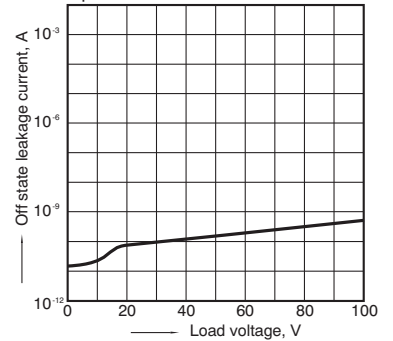

10.-(1) Turn on time vs. LED forward current characteristics

Measured portion: between terminals 4 and 6; Load voltage: Max. (DC); Continuous load current: Max. (DC); Ambient temperature: 25°C 77°F

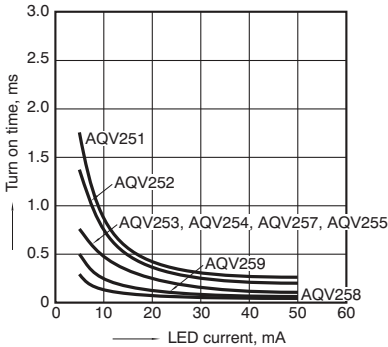

10.-(2) Turn on time vs. LED forward current characteristics

Measured portion: between terminals 4 and 6; Load voltage: Max. (DC); Continuous load current: Max. (DC); Ambient temperature: 25°C 77°F

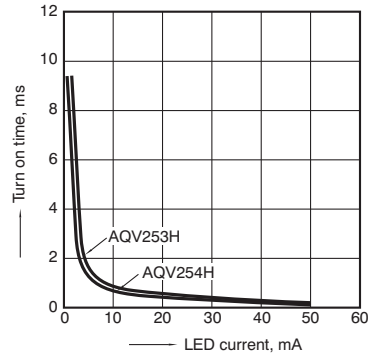

11.-(1) Turn off time vs. LED forward current characteristics

Measured portion: between terminals 4 and 6; Load voltage: Max. (DC); Continuous load current: Max. (DC); Ambient temperature: 25°C 77°F

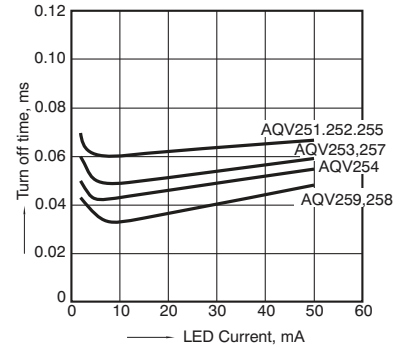

11.-(2) Turn off time vs. LED forward current characteristics

Measured portion: between terminals 4 and 6; Load voltage: Max. (DC); Continuous load current: Max. (DC); Ambient temperature: 25°C 77°F

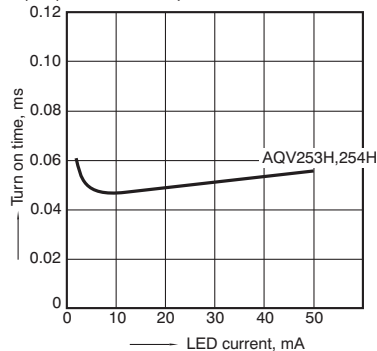

12.-(1) Output capacitance vs. applied voltage characteristics

Measured portion: between terminals 4 and 6; Frequency: 1 MHz; Ambient temperature: 25°C 77°F

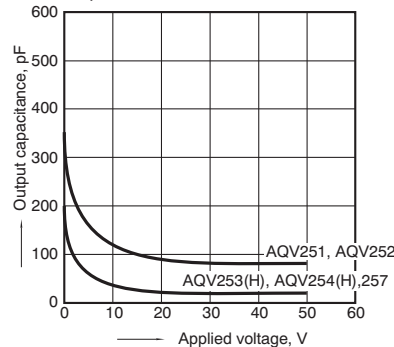

12.-(2) Output capacitance vs. applied voltage characteristics

Sample: AQV259; Measured portion: between terminals 4 and 6; Frequency: 1 MHz; Ambient temperature: 25°C 77°F

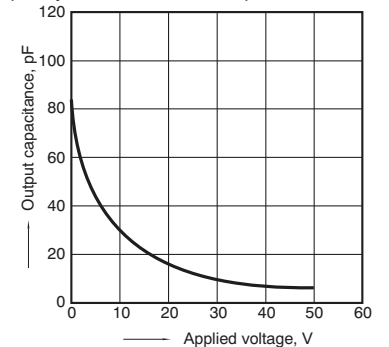

Panasonic

ideas for life



Miniature SOP6-pin type
with high capacity
of 1.25A load current

PhotoMOS[®]
HE SOP 1 Form A
High Capacity (AQV255GS)

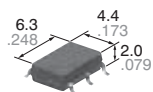

CAD Data

mm inch

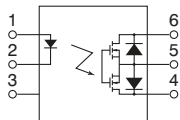

FEATURES

1. High capacity in a miniature SOP package

Continuous load current: 1.25A

Load voltage: 80V

2. Greatly improved specifications allow you to use this in place of mercury and mechanical relays.

TYPICAL APPLICATIONS

- Security equipment
- Fire-preventing system
- Measuring instruments

TYPES

	Output rating*		Package	Part No.			Packing quantity	
	Load voltage	Load current		Surface-mount terminal			Tube	Tape and reel
				Tube packing style	Tape and reel packing style			
			Picked from the 1/2/3-pin side		Picked from the 4/5/6-pin side			
AC/DC dual use	80 V	1.25 A	SOP6-pin	AQV255GS	AQV255GSX	AQV255GSZ	1 tube contains: 75 pcs. 1 batch contains: 1,500 pcs.	1,000 pcs.

*Indicate the peak AC and DC values.

Note: For space reasons, the two initial letters of the part number "AQ" and the packing style indicator "X" or "Z" are not marked on the relay.

RATING

1. Absolute maximum ratings (Ambient temperature: 25°C 77°F)

Item		Symbol	Type of connection	AQV255GS	Remarks
Input	LED forward current	I_F		50 mA	
	LED reverse voltage	V_R		5 V	
	Peak forward current	I_{FP}		1 A	$f = 100 \text{ Hz}$, Duty factor = 0.1%
	Power dissipation	P_{in}		75 mW	
Load voltage (peak AC)		V_L		80 V	
Output	Continuous load current	I_L	A	1.25 A	A connection: Peak AC, DC B, C connection: DC
			B	1.75 A	
			C	2.5 A	
Peak load current		I_{peak}		3 A	100ms (1 shot), $V_L = \text{DC}$
Power dissipation		P_{out}		450 mW	
Total power dissipation		P_T		500 mW	
I/O isolation voltage		V_{iso}		1,500 V AC	
Temperature limits	Operating	T_{opr}		-40°C to +85°C -40°F to +185°F	Non-condensing at low temperatures
	Storage	T_{stg}		-40°C to +100°C -40°F to +212°F	

HE SOP 1 Form A High Capacity (AQV255GS)

2. Electrical characteristics (Ambient temperature: 25°C 77°F)

Item			Symbol	Type of connection	AQV255GS	Condition
Input	LED operate current	Typical	I_{Fon}	—	0.5 mA	$I_L = 100\text{mA}$
		Maximum			3 mA	
	LED turn off current	Minimum	I_{Foff}	—	0.2 mA	$I_L = 100\text{mA}$
		Typical			0.4 mA	
LED dropout voltage	Typical	V_F	—	1.32 V (1.14 V at $I_F = 5\text{ mA}$)		$I_F = 50\text{ mA}$
	Maximum			1.5 V		
Output	On resistance	Typical	R_{on}	A	0.09 Ω	$I_F = 5\text{ mA}$ $I_L = \text{Max.}$ Within 1 s on time
		Maximum		0.15 Ω		
		Typical	R_{on}	B	0.05 Ω	
		Maximum		0.12 Ω		
		Typical	R_{on}	C	0.03 Ω	
		Maximum		0.1 Ω		
Off state leakage current	Maximum	I_{Leak}	—	1 μA	$I_F = 0\text{ mA}, V_L = \text{Max.}$	
Transfer characteristics	Turn on time*	Typical	T_{on}	—	1.3 ms	$I_F = 5\text{ mA}, I_L = 100\text{ mA}$ $V_L = 10\text{ V}$
		Maximum			5 ms	
	Turn off time*	Typical	T_{off}	—	0.1 ms	$I_F = 5\text{ mA}, I_L = 100\text{ mA}$ $V_L = 10\text{ V}$
		Maximum			0.5 ms	
	I/O capacitance	Typical	C_{iso}	—	0.8 pF	$f = 1\text{ MHz}$ $V_b = 0\text{ V}$
Maximum		1.5 pF				
Initial I/O isolation resistance	Minimum	R_{iso}	—	1,000 M Ω	500 V DC	
Max. switching frequency	Maximum	—	—	5 times/s	$I_F = 5\text{ mA}, \text{duty} = 50\%$ $V_L \times I_L = 100\text{ V}\cdot\text{A}$	

*Turn on/Turn off time

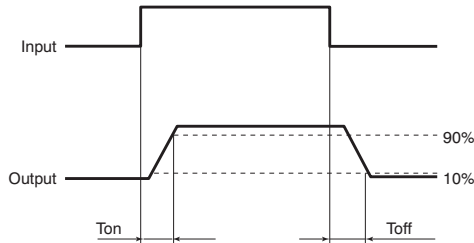

RECOMMENDED OPERATING CONDITIONS

Please obey the following conditions to ensure proper relay operation and resetting.

Item	Symbol	Recommended value	Unit
Input LED current	I_F	5 to 10	mA

■ For Dimensions, see page 62.

■ For Schematic and Wiring Diagrams, see page 65.

■ For Cautions for Use, see page 71.

■ These products are not designed for automotive use.

If you are considering to use these products for automotive applications, please contact your local Panasonic technical representative.

For more information, see page 80.

REFERENCE DATA

13. Load current vs. ambient temperature characteristics

Allowable ambient temperature: -40°C to $+85^\circ\text{C}$
 -40°F to $+185^\circ\text{F}$

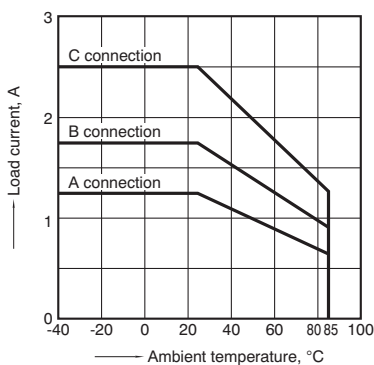

14. On resistance vs. ambient temperature characteristics

Measured portion: between terminals 4 and 6;
LED current: 5 mA; Load voltage: Max. (DC)
Continuous load current: Max. (DC)

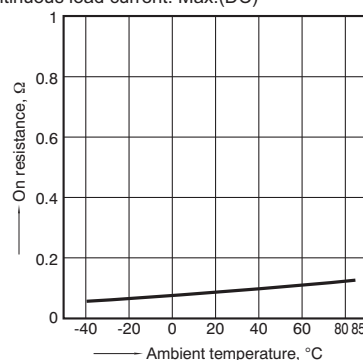

15. Turn on time vs. ambient temperature characteristics

LED current: 5 mA; Load voltage: 10 V (DC);
Continuous load current: 100 mA (DC)

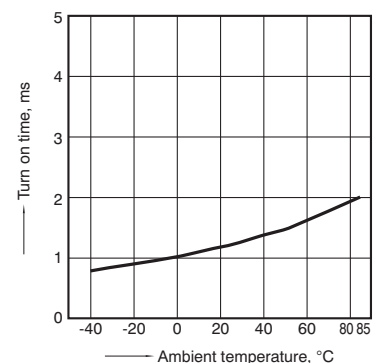

ds_x615_en_aqv255gs: 010611J

249

HE SOP 1 Form A High Capacity (AQV255GS)

16. Turn off time vs. ambient temperature characteristics

LED current: 5 mA; Load voltage: 10 V (DC);
Continuous load current: 100 mA (DC)

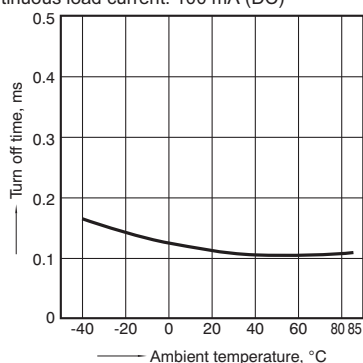

17. LED operate current vs. ambient temperature characteristics

Load voltage: 10 V (DC);
Continuous load current: 100mA (DC)

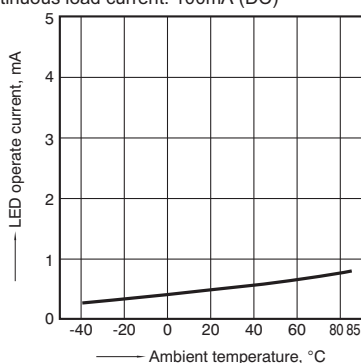

18. LED turn off current vs. ambient temperature characteristics

Load voltage: 10 V (DC);
Continuous load current: 100mA (DC)

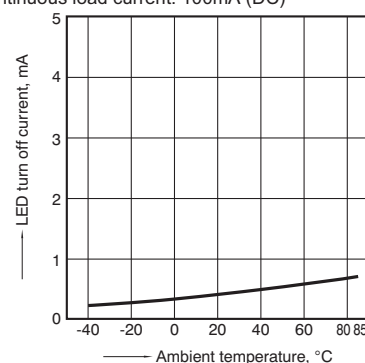

19. LED dropout voltage vs. ambient temperature characteristics

LED current: 5 to 50 mA

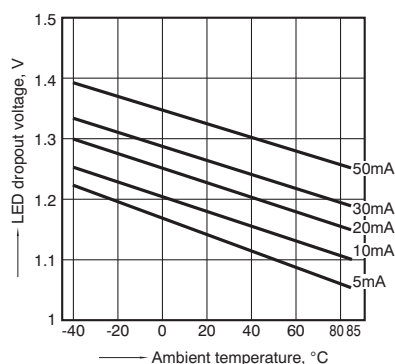

20. Current vs. voltage characteristics of output at MOS portion

Measured portion: between terminals 4 and 6;
Ambient temperature: 25°C 77°F

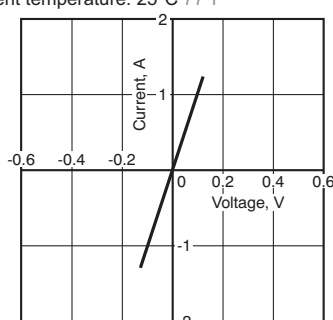

21. Off state leakage current vs. load voltage characteristics

Measured portion: between terminals 4 and 6;
Ambient temperature: 25°C 77°F

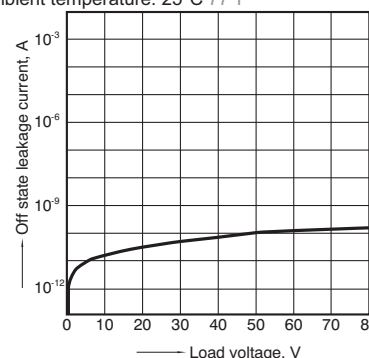

22. Turn on time vs. LED forward current characteristics

Measured portion: between terminals 4 and 6;
Load voltage: 10 V (DC);
Continuous load current: 100 mA (DC);
Ambient temperature: 25°C 77°F

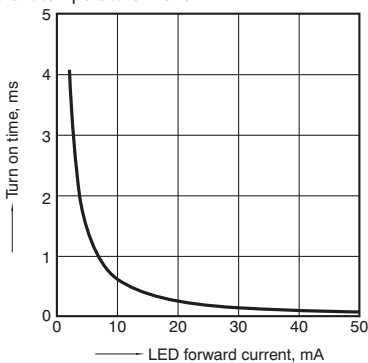

23. Turn off time vs. LED forward current characteristics

Measured portion: between terminals 4 and 6;
Load voltage: 10 V (DC);
Continuous load current: 100 mA (DC);
Ambient temperature: 25°C 77°F

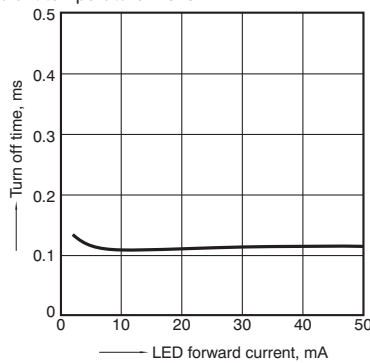

24. Output capacitance vs. applied voltage characteristics

Measured portion: between terminals 4 and 6;
Frequency: 1 MHz;
Ambient temperature: 25°C 77°F

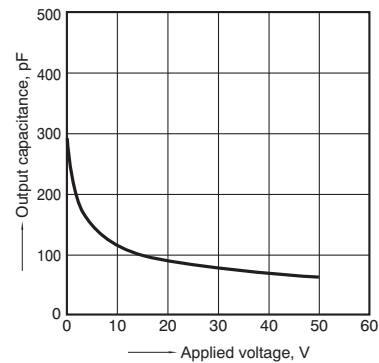

25. Max. switching frequency vs. load voltage and load current

LED current: 5 mA
Ambient temperature: 25°C 77°F

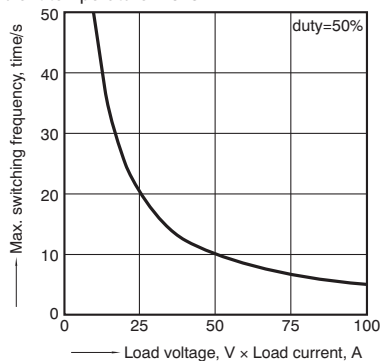

Panasonic

ideas for life



DIP6-pin type
with high capacity
of 2.5A load current

PhotoMOS[®]
HE 1 Form A
High Capacity

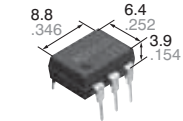

(Height includes
standoff)

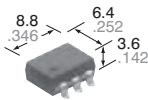

CAD Data

mm inch

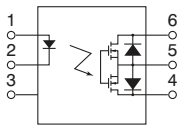

FEATURES

1. Greatly increased load current in a compact DIP package
Continuous load current: 2.5A
2. Greatly improved specifications allow you to use this in place of mercury and mechanical relays.

TYPICAL APPLICATIONS

- Security equipment
- Fire-preventing system
- Measuring instruments

PhotoMOS

TYPES

	Output rating*		Package	Part No.				Packing quantity	
				Through hole terminal	Surface-mount terminal		Tube	Tape and reel	
	Load voltage	Load current			Tube packing style				Tape and reel packing style
AC/DC dual use	60 V	2.5 A	DIP6-pin	AQV252G	AQV252GA	AQV252GAX	AQV252GAZ	1 tube contains: 50 pcs. 1 batch contains: 500 pcs.	1,000 pcs.

*Indicate the peak AC and DC values.

Note: The surface mount terminal indicator "A" and the packing style indicator "X" or "Z" are not marked on the relay.

RATING

1. Absolute maximum ratings (Ambient temperature: 25°C 77°F)

Item		Symbol	Type of connection	AQV252G(A)	Remarks
Input	LED forward current	I_F		50 mA	
	LED reverse voltage	V_R		5 V	
	Peak forward current	I_{FP}		1 A	$f = 100 \text{ Hz}$, Duty factor = 0.1%
	Power dissipation	P_{in}		75 mW	
Load voltage (peak AC)		V_L		60 V	
Output	Continuous load current	I_L	A	2.5 A	A connection: Peak AC, DC B, C connection: DC
			B	3.5 A	
			C	5.0 A	
Peak load current		I_{peak}		6.0 A	100ms (1 shot), $V_L = \text{DC}$
Power dissipation		P_{out}		500 mW	
Total power dissipation		P_T		550 mW	
I/O isolation voltage		V_{iso}		1,500 V AC	
Temperature limits	Operating	T_{opr}		-40°C to +85°C -40°F to +185°F	Non-condensing at low temperatures
	Storage	T_{stg}		-40°C to +100°C -40°F to +212°F	

HE 1 Form A High Capacity

2. Electrical characteristics (Ambient temperature: 25°C 77°F)

Item		Symbol	Type of connection	AQV252G(A)	Condition
Input	LED operate current	Typical	I _{Fon}	0.5 mA	I _L = 100mA
		Maximum		3 mA	
	LED turn off current	Minimum	I _{Foff}	0.2 mA	I _L = 100mA
		Typical		0.45 mA	
LED dropout voltage	Typical	V _F	1.14 V (1.32 V at I _F = 50 mA)		I _F = 5 mA
	Maximum		1.5 V		
Output	On resistance	Typical	R _{on}	0.08 Ω	I _F = 5 mA I _L = Max. Within 1 s on time
		Maximum		0.12 Ω	
		Typical	R _{on}	0.04 Ω	
		Maximum		0.06 Ω	
		Typical	R _{on}	0.02 Ω	
		Maximum		0.03 Ω	
Off state leakage current	Maximum	I _{Leak}	1 μA	I _F = 0 mA, V _L = Max.	
Transfer characteristics	Turn on time*	Typical	T _{on}	1.1 ms	I _F = 5 mA, I _L = 100 mA V _L = 10 V
		Maximum		5.0 ms	
	Turn off time*	Typical	T _{off}	0.25 ms	I _F = 5 mA, I _L = 100 mA V _L = 10 V
		Maximum		0.5 ms	
	I/O capacitance	Typical	C _{iso}	0.8 pF	f = 1 MHz
Maximum		1.5 pF		V _B = 0 V	
Initial I/O isolation resistance	Minimum	R _{iso}	1,000 MΩ	500 V DC	

*Turn on/Turn off time

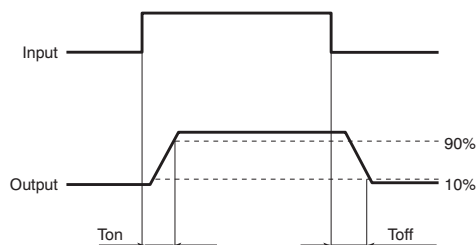

RECOMMENDED OPERATING CONDITIONS

Please obey the following conditions to ensure proper relay operation and resetting.

Item	Symbol	Recommended value	Unit
Input LED current	I _F	5 to 10	mA

■ For Dimensions, see page 60.

■ For Schematic and Wiring Diagrams, see page 65.

■ For Cautions for Use, see page 71.

■ These products are not designed for automotive use.

If you are considering to use these products for automotive applications, please contact your local Panasonic technical representative.

For more information, see page 80.

REFERENCE DATA

1. Load current vs. ambient temperature characteristics

Allowable ambient temperature: -40°C to +85°C
-40°F to +185°F

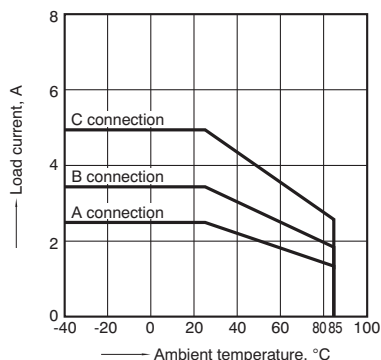

2. On resistance vs. ambient temperature characteristics

Measured portion: between terminals 4 and 6;
LED current: 5 mA; Load voltage: Max. (DC)
Continuous load current: Max. (DC)

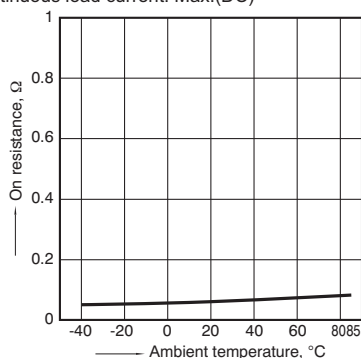

3. Turn on time vs. ambient temperature characteristics

LED current: 5 mA; Load voltage: 10 V (DC);
Continuous load current: 100 mA (DC)

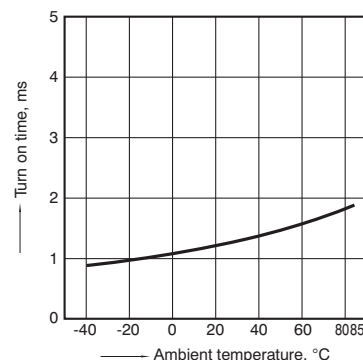

HE 1 Form A High Capacity

4. Turn off time vs. ambient temperature characteristics

LED current: 5 mA; Load voltage: 10 V (DC);
Continuous load current: 100 mA (DC)

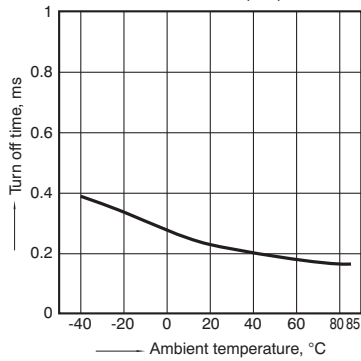

5. LED operate current vs. ambient temperature characteristics

Load voltage: 10 V (DC);
Continuous load current: 100 mA (DC)

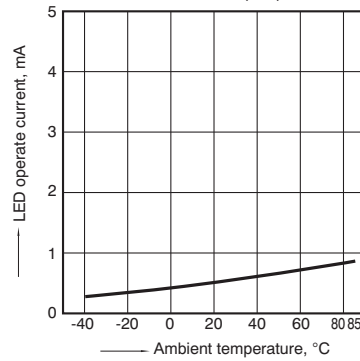

6. LED turn off current vs. ambient temperature characteristics

Load voltage: 10 V (DC);
Continuous load current: 100 mA (DC)

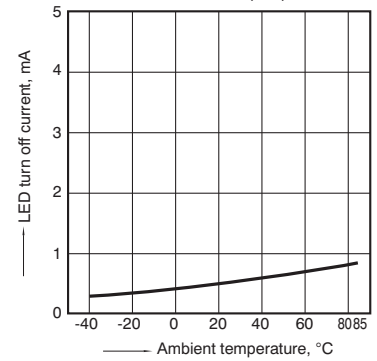

7. LED dropout voltage vs. ambient temperature characteristics

LED current: 5 to 50 mA

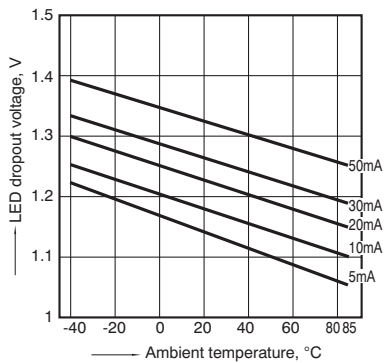

8. Current vs. voltage characteristics of output at MOS portion

Measured portion: between terminals 4 and 6;
Ambient temperature: 25°C 77°F

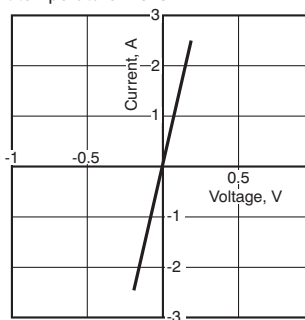

9. Off state leakage current vs. load voltage characteristics

Measured portion: between terminals 4 and 6;
Ambient temperature: 25°C 77°F

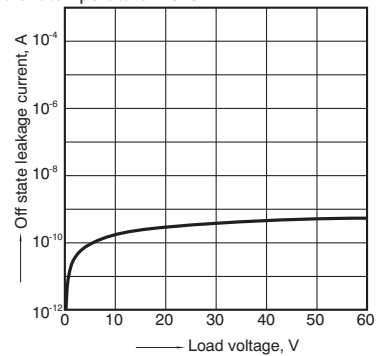

10. Turn on time vs. LED forward current characteristics

Measured portion: between terminals 4 and 6;
Load voltage: 10 V (DC);
Continuous load current: 100 mA (DC);
Ambient temperature: 25°C 77°F

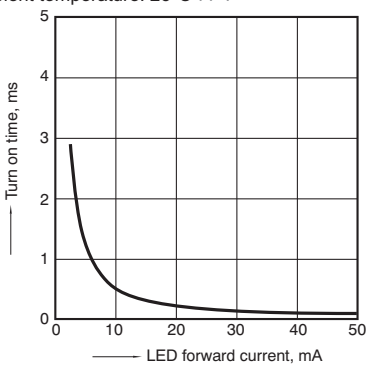

11. Turn off time vs. LED forward current characteristics

Measured portion: between terminals 4 and 6;
Load voltage: 10 V (DC);
Continuous load current: 100 mA (DC);
Ambient temperature: 25°C 77°F

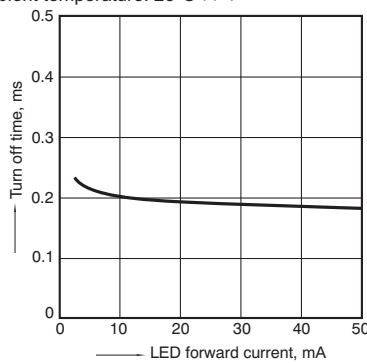

12. Output capacitance vs. applied voltage characteristics

Measured portion: between terminals 4 and 6;
Frequency: 1 MHz;
Ambient temperature: 25°C 77°F

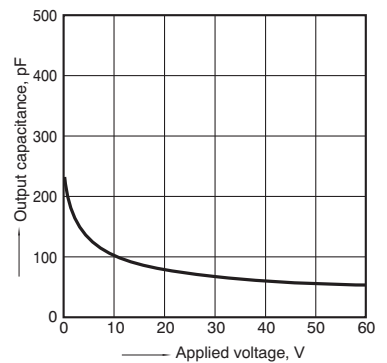

Panasonic

ideas for life



**DIP8-pin type
featuring low on-resistance
with 400V load voltage**

**PhotoMOS[®]
HE 2 Form A
(AQW254)**

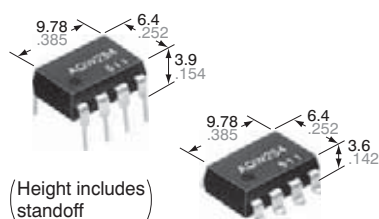

CAD Data

mm inch

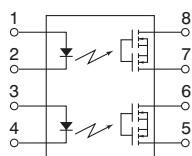

FEATURES

1. High sensitivity and low on-resistance

Can control max. 0.16 A load current with 5 mA input current. Low on-resistance of typ. 10.2Ω.

2. Applicable for 2 Form A use as well as two independent 1 Form A use

3. Controls low-level analog signals

PhotoMOS relays feature extremely low closed-circuit offset voltage to enable control of low-level analog signals without distortion.

4. Low-level off state leakage current of max. 1 μA

TYPICAL APPLICATIONS

- High-speed inspection machines
- Data communication equipment
- Telephone equipment

TYPES

	Output rating*		Package	Part No.				Packing quantity	
				Through hole terminal	Surface-mount terminal		Tube	Tape and reel	
	Load voltage	Load current			Tube packing style	Tape and reel packing style			
AC/DC dual use	400 V	120 mA	DIP8-pin	AQW254	AQW254A	Picked from the 1/2/3/4-pin side AQW254AX	Picked from the 5/6/7/8-pin side AQW254AZ	1 tube contains: 50 pcs. 1 batch contains: 500 pcs.	1,000 pcs

*Indicate the peak AC and DC values.

Note: The surface mount terminal indicator "A" and the packing style indicator "X" or "Z" are not marked on the relay.

RATING

1. Absolute maximum ratings (Ambient temperature: 25°C 77°F)

Item		Symbol	AQW254(A)	Remarks
Input	LED forward current	I_F	50 mA	
	LED reverse voltage	V_R	5 V	
	Peak forward current	I_{FP}	1 A	$f = 100 \text{ Hz}$, Duty factor = 0.1%
	Power dissipation	P_{in}	75 mW	
Output	Load voltage (peak AC)	V_L	400 V	
	Continuous load current	I_L	0.12 A (0.16 A)	A connection: Peak AC, DC () in case of using only 1 channel
	Peak load current	I_{peak}	0.36 A	A connection: 100 ms (1 shot), $V_L = \text{DC}$
	Power dissipation	P_{out}	800 mW	
Total power dissipation		P_T	850 mW	
I/O isolation voltage		V_{iso}	1,500 V AC	Between input and output/between contact sets
Temperature limits	Operating	T_{opr}	-40°C to +85°C -40°F to +185°F	Non-condensing at low temperatures
	Storage	T_{stg}	-40°C to +100°C -40°F to +212°F	

HE 2 Form A (AQW254)

2. Electrical characteristics (Ambient temperature: 25°C 77°F)

Item		Symbol	AQW254(A)	Condition
Input	LED operate current	Typical	0.9 mA	$I_L = \text{Max.}$
		Maximum	3 mA	
	LED turn off current	Minimum	0.4 mA	$I_L = \text{Max.}$
		Typical	0.8 mA	
LED dropout voltage	Typical	V_F	1.25 V (1.14 V at $I_F = 5 \text{ mA}$)	$I_F = 50 \text{ mA}$
	Maximum		1.5 V	
Output	On resistance	Typical	10.2 Ω	$I_F = 5 \text{ mA}$ $I_L = \text{Max.}$ Within 1 s on time
		Maximum	16 Ω	
	Off state leakage current	Maximum	1 μA	$I_F = 0 \text{ mA}$ $V_L = \text{Max.}$
Transfer characteristics	Turn on time*	Typical	0.8 ms	$I_F = 5 \text{ mA}$ $I_L = \text{Max.}$
		Maximum	2 ms	
	Turn off time*	Typical	0.04 ms	$I_F = 5 \text{ mA}$ $I_L = \text{Max.}$
		Maximum	0.2 ms	
	I/O capacitance	Typical	C_{iso}	0.8 pF
Maximum		1.5 pF		
Initial I/O isolation resistance	Minimum	R_{iso}	1,000 M Ω	500 V DC

*Turn on/Turn off time

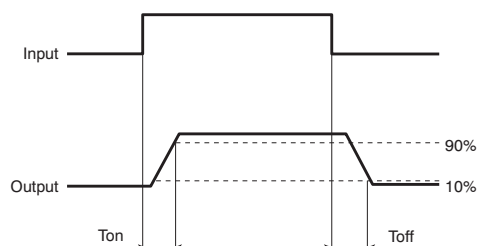

RECOMMENDED OPERATING CONDITIONS

Please obey the following conditions to ensure proper relay operation and resetting.

Item	Symbol	Recommended value	Unit
Input LED current	I_F	5	mA

■ For Dimensions, see page 61.

■ For Schematic and Wiring Diagrams, see page 65.

■ For Cautions for Use, see page 71.

■ These products are not designed for automotive use.

If you are considering to use these products for automotive applications, please contact your local Panasonic technical representative.

For more information, see page 80.

REFERENCE DATA

1. Load current vs. ambient temperature characteristics

Allowable ambient temperature: -40°C to $+85^\circ\text{C}$
 -40°F to $+185^\circ\text{F}$

When using 2 channels

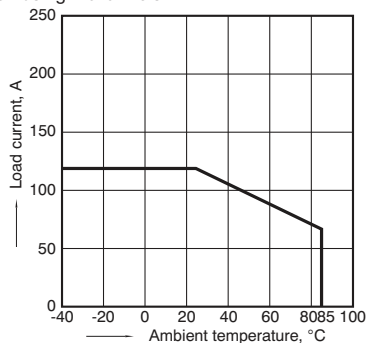

2. On resistance vs. ambient temperature characteristics

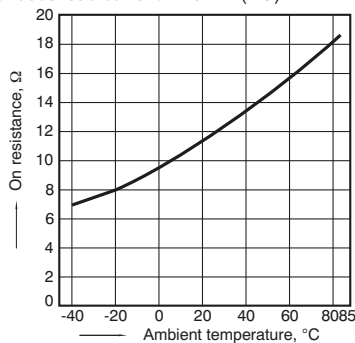
Measured portion: between terminals 5 and 6,
7 and 8; LED current: 5 mA; Load voltage: 400 V (DC);
Continuous load current: 120 mA (DC)

3. Turn on time vs. ambient temperature characteristics

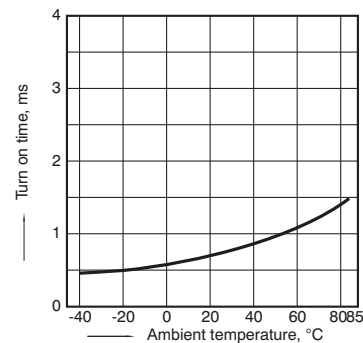
LED current: 5 mA; Load voltage: 400 V (DC);
Continuous load current: 120 mA (DC)

HE 2 Form A (AQW254)

4. Turn off time vs. ambient temperature characteristics

LED current: 5 mA; Load voltage: 400 V (DC);
Continuous load current: 120 mA (DC)

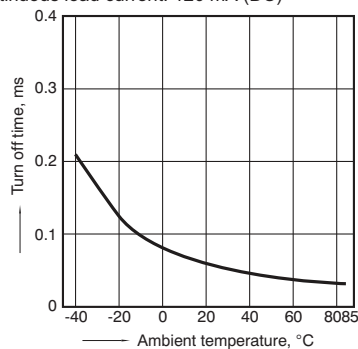

5. LED operate current vs. ambient temperature characteristics

Load voltage: 400 V (DC);
Continuous load current: 120 mA (DC)

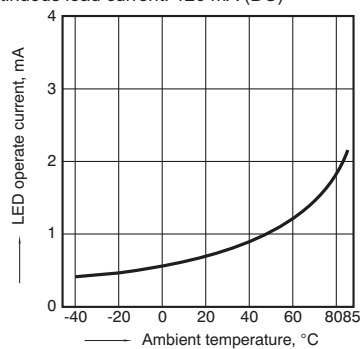

6. LED turn off current vs. ambient temperature characteristics

Load voltage: 400 V (DC);
Continuous load current: 120 mA (DC)

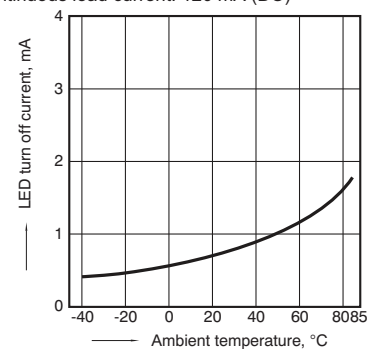

7. LED dropout voltage vs. ambient temperature characteristics

LED current: 5 to 50 mA

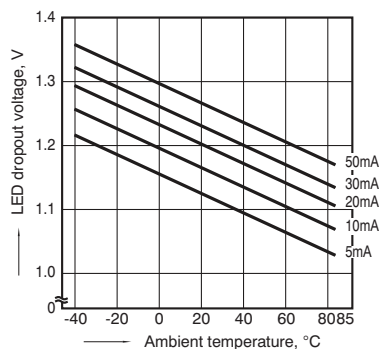

8. Current vs. voltage characteristics of output at MOS portion

Measured portion: between terminals 5 and 6,
7 and 8; Ambient temperature: 25°C 77°F

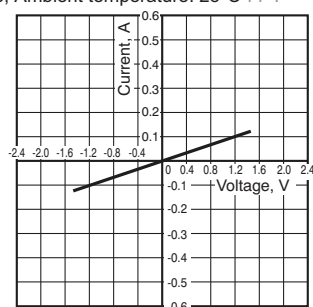

9. Off state leakage current vs. load voltage characteristics

Measured portion: between terminals 5 and 6,
7 and 8; Ambient temperature: 25°C 77°F

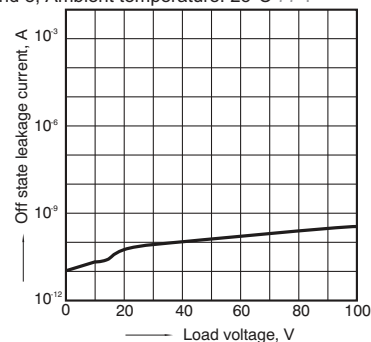

10. Turn on time vs. LED forward current characteristics

Measured portion: between terminals 5 and 6, 7 and 8; Load voltage: 400 V (DC); Continuous load current: 120 mA (DC); Ambient temperature: 25°C 77°F

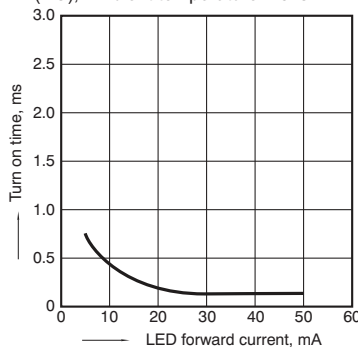

11. Turn off time vs. LED forward current characteristics

Measured portion: between terminals 5 and 6, 7 and 8; Load voltage: 400 V (DC); Continuous load current: 120 mA (DC); Ambient temperature: 25°C 77°F

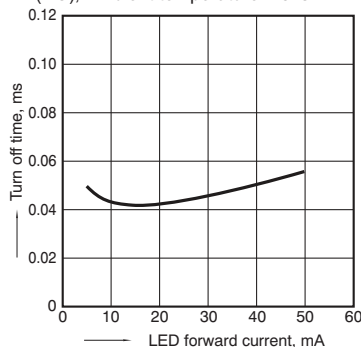

12. Output capacitance vs. applied voltage characteristics

Measured portion: between terminals 5 and 6, 7 and 8; Frequency: 1 MHz; Ambient temperature: 25°C 77°F

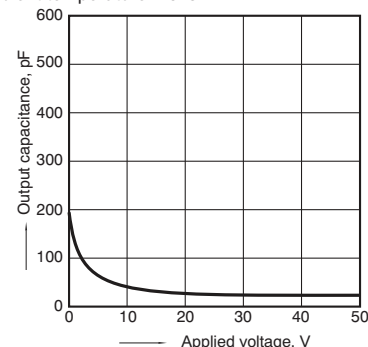

Panasonic

ideas for life

**Normally closed
DIP6-pin type
Low on-resistance with
250V/400V load voltage**

**PhotoMOS[®]
HE 1 Form B
(AQV450, AQV454H)**

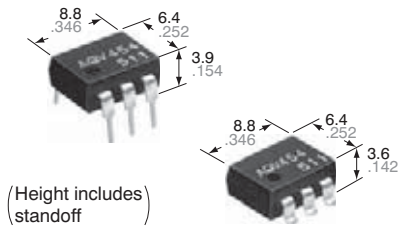

CAD Data

mm inch

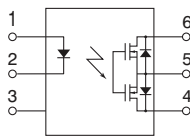

FEATURES

1. 1 Form B (Normally-closed) type with low on-resistance

This has been achieved thanks to the built-in MOSFET processed by our proprietary method, DSD (Double-diffused and Selective Doping) method.

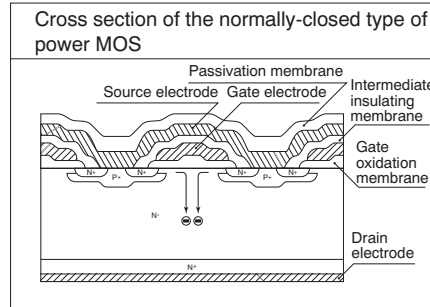

2. Controls low-level analog signals

PhotoMOS relays feature extremely low closed-circuit offset voltage to enable control of low-level analog signals without distortion.

3. High sensitivity and low on-resistance

Can control max. 0.2 A load current with 5 mA input current. Low on-resistance of typ. 5.5 Ω (AQV453).

4. Reinforced insulation 5,000 V type also available.

More than 0.4 mm .016 inch internal insulation distance between inputs and outputs. Conforms to IEC950 (reinforced insulation).

TYPICAL APPLICATIONS

- Security equipment
- High-speed inspection machines
- Measuring instruments
- Telephone equipment
- Sensing equipment

TYPES

	I/O isolation	Output rating*		Package	Part No.				Packing quantity	
		Load voltage	Load current		Through hole terminal	Surface-mount terminal		Tube	Tape and reel	
						Tape and reel packing style				
					Tube packing style	Picked from the 1/2/3-pin side	Picked from the 4/5/6-pin side			
AC/DC dual use	1,500 V AC	250 V	200 mA	DIP6-pin	AQV453	AQV453A	AQV453AX	AQV453AZ	1 tube contains: 50 pcs. 1 batch contains: 500 pcs.	1,000 pcs.
		400 V	150 mA		AQV454	AQV454A	AQV454AX	AQV454AZ		
	Reinforced 5,000 V AC				AQV454H	AQV454HA	AQV454HAX	AQV454HAZ		

* Indicate the peak AC and DC values.

Note: The surface mount terminal indicator "A" and the packing style indicator "X" or "Z" are not marked on the relay.

RATING

1. Absolute maximum ratings (Ambient temperature: 25°C 77°F)

Item		Symbol	Type of connection	AQV453(A)	AQV454(A)	AQV454H(A)	Remarks
Input	LED forward current	I _F		50 mA			
	LED reverse voltage	V _R		5 V			
	Peak forward current	I _{FP}		1 A			f = 100 Hz, Duty factor = 0.1%
	Power dissipation	P _{in}		75 mW			
Output	Load voltage (peak AC)	V _L		250 V	400 V		
	Continuous load current	I _L	A	0.2 A	0.15 A		A connection: Peak AC, DC
			B	0.3 A	0.18 A		B, C connection: DC
			C	0.4 A	0.25 A		
	Peak load current	I _{PEAK}		0.6 A	0.5 A		A connection: 100 ms (1 shot), V _L = DC
	Power dissipation	P _{OUT}		360 mW			
Total power dissipation	P _T		410 mW				
I/O isolation voltage		V _{iso}		1,500 V AC		5,000 V AC	
Temperature limits	Operating	T _{opr}		-40°C to +85°C -40°F to +185°F			Non-condensing at low temperatures
	Storage	T _{stg}		-40°C to +100°C -40°F to +212°F			

HE 1 Form B (AQV450, AQV454H)

2. Electrical characteristics (Ambient temperature: 25°C 77°F)

Item		Symbol	Type of connection	AQV453(A)	AQV454(A)	AQV454H(A)	Remarks
Input	LED operate (OFF) current	Typical	—	1 mA	0.9 mA	1.4 mA	$I_L = \text{Max.}$
		Maximum		3 mA			
	LED reverse (ON) current	Minimum	—	0.4 mA			$I_L = \text{Max.}$
		Typical		0.9 mA	0.8 mA	1.3 mA	
LED dropout voltage	Typical	—	1.25 V (1.14 V at $I_F=5 \text{ mA}$)			$I_F = 50 \text{ mA}$	
	Maximum		1.5 V				
Output	On resistance	Typical	A	5.5 Ω	11 Ω		$I_F = 0 \text{ mA}$ $I_L = \text{Max.}$ Within 1 s on time
		Maximum		8 Ω	16 Ω		
		Typical	B	2.7 Ω	6.3 Ω		$I_F = 0 \text{ mA}$ $I_L = \text{Max.}$ Within 1 s on time
		Maximum		4 Ω	8 Ω		
	Typical	C	1.4 Ω	3.1 Ω		$I_F = 0 \text{ mA}$ $I_L = \text{Max.}$ Within 1 s on time	
	Maximum		2 Ω	4 Ω			
Off state leakage current	Maximum	—	1 μA	1 μA	10 μA	$I_F = 5 \text{ mA}$ $V_L = \text{Max.}$	
Transfer characteristics	Operate (OFF) time*	Typical	—	1.52 ms	1.2 ms	1.8 ms	$I_F = 0 \text{ mA} \rightarrow 5 \text{ mA}$ $I_L = \text{Max.}$
		Maximum		3 ms	2.0 ms	3.0 ms	
	Reverse (ON) time*	Typical	—	0.4 ms			$I_F = 5 \text{ mA} \rightarrow 0 \text{ mA}$ $I_L = \text{Max.}$
		Maximum		1 ms			
	I/O capacitance	Typical	—	1.3 pF			$f = 1 \text{ MHz}$ $V_B = 0 \text{ V}$
Maximum		3 pF					
Initial I/O isolation resistance	Minimum	—	1,000 M Ω			500 V DC	

*Operate/Reverse time

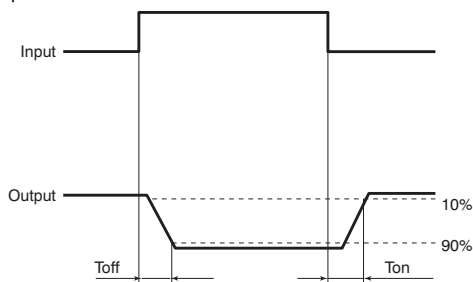

RECOMMENDED OPERATING CONDITIONS

Please obey the following conditions to ensure proper relay operation and resetting.

Item	Symbol	Recommended value	Unit
Input LED current	I_F	Standard type: 5 Reinforced insulation type: 5 to 10	mA

■ For Dimensions, see page 60.

■ For Schematic and Wiring Diagrams, see page 66.

■ For Cautions for Use, see page 71.

■ These products are not designed for automotive use.

If you are considering to use these products for automotive applications, please contact your local Panasonic technical representative.

For more information, see page 80.

REFERENCE DATA

1. Load current vs. ambient temperature characteristics

Allowable ambient temperature: -40°C to $+85^\circ\text{C}$
 -40°F to $+185^\circ\text{F}$

Type of connection: A

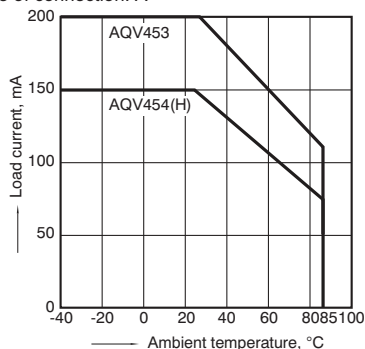

2. On resistance vs. ambient temperature characteristics

Measured portion: between terminals 4 and 6;
LED current: 0 mA; Load voltage: Max. (DC);
Continuous load current: Max. (DC)

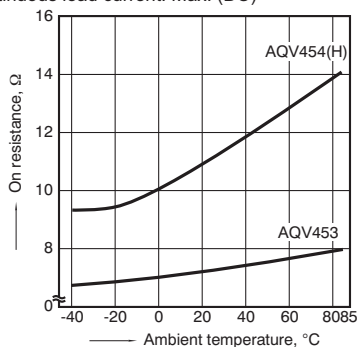

3. Operate (OFF) time vs. ambient temperature characteristics

LED current: 5 mA; Load voltage: Max. (DC);
Continuous load current: Max. (DC)

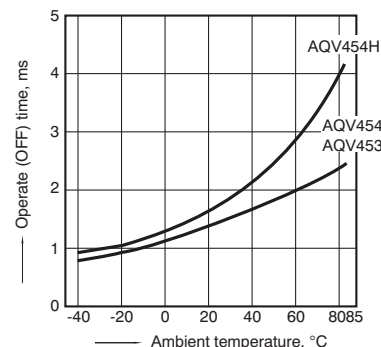

HE 1 Form B (AQV45○, AQV454H)

4. Reverse (ON) time vs. ambient temperature characteristics

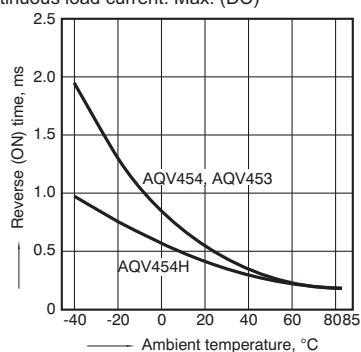
LED current: 5 mA; Load voltage: Max. (DC);
Continuous load current: Max. (DC)

5. LED operate (OFF) current vs. ambient temperature characteristics

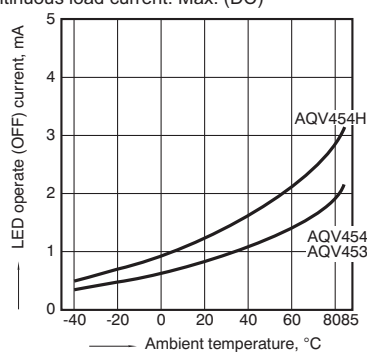
Load voltage: Max. (DC);
Continuous load current: Max. (DC)

6. LED reverse (ON) current vs. ambient temperature characteristics

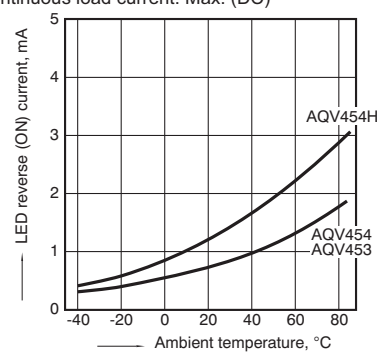
Load voltage: Max. (DC);
Continuous load current: Max. (DC)

7. LED dropout voltage vs. ambient temperature characteristics

LED current: 5 to 50 mA

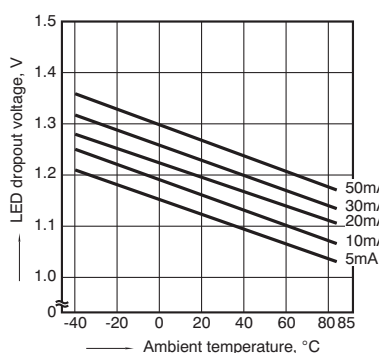

8. Current vs. voltage characteristics of output at MOS portion

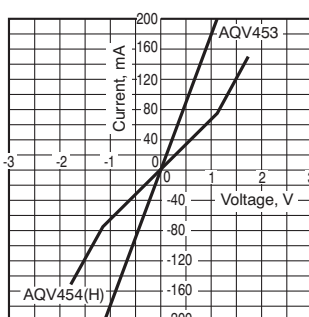
Measured portion: between terminals 4 and 6;
Ambient temperature: 25°C 77°F

9. Off state leakage current vs. load voltage characteristics

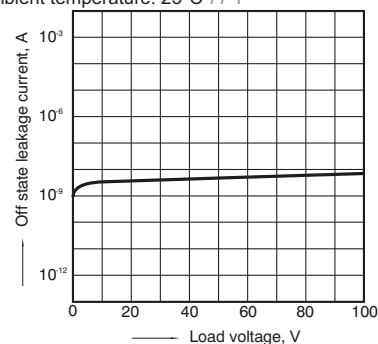
Sample: AQV454;
Measured portion: between terminals 4 and 6;
Ambient temperature: 25°C 77°F

10. Operate (OFF) time vs. LED forward current characteristics

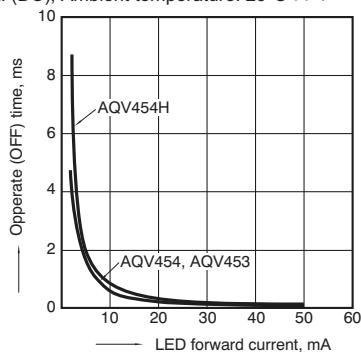
Measured portion: between terminals 4 and 6;
Load voltage: Max. (DC); Continuous load current:
Max. (DC); Ambient temperature: 25°C 77°F

11. Reverse (ON) time vs. LED forward current characteristics

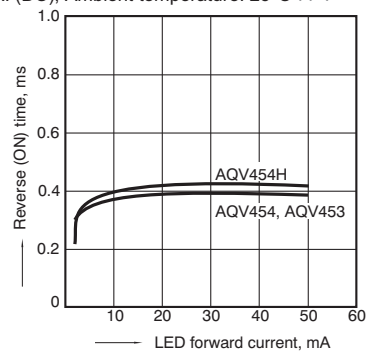
Measured portion: between terminals 4 and 6;
Load voltage: Max. (DC); Continuous load current:
Max. (DC); Ambient temperature: 25°C 77°F

12. Output capacitance vs. applied voltage characteristics

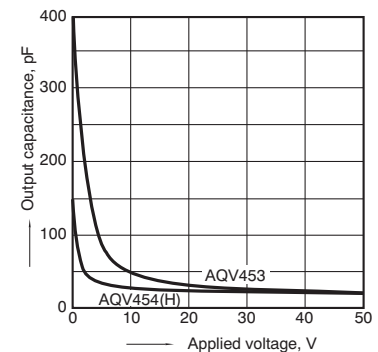
Measured portion: between terminals 4 and 6;
Frequency: 1 MHz; Ambient temperature: 25°C 77°F

Panasonic

ideas for life

**Normally closed (2 Form A)
DIP6-pin type
Low on-resistance with
400V load voltage**

**PhotoMOS[®]
HE 2 Form B
(AQW454)**

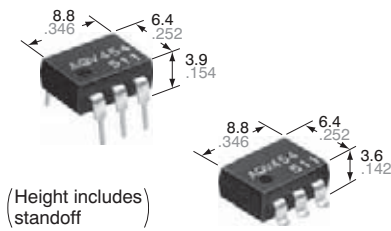

CAD Data

mm inch

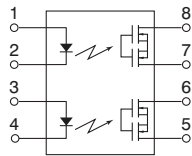

FEATURES

1. 2 Form B (Normally-closed) type

Has been realized thanks to the built-in MOSFET processed by our proprietary method, DSD (Double-diffused and Selective Doping) method.

2. Applicable for 2 Form B use as well as two independent 1 Form B use.

3. Controls low-level analog signals

PhotoMOS relays feature extremely low closed-circuit offset voltage to enable control of low-level analog signals without distortion.

4. High sensitivity and low on-resistance

Can control max. 0.16 A load current with 5 mA input current. Low on-resistance of typ. 11 Ω .

5. Low-level off state leakage current of max. 1 μ A

TYPICAL APPLICATIONS

- Security equipment
- High-speed inspection machine
- Measuring instruments
- Telecommunication equipment
- Sensing equipment

TYPES

	Output rating*		Package	Part No.				Packing quantity	
				Through hole terminal	Surface-mount terminal			Tube	Tape and reel
	Load voltage	Load current		Tube packing style		Tape and reel packing style			
					Picked from the 1/2/3/4-pin side	Picked from the 5/6/7/8-pin side			
AC/DC dual use	400 V	120 mA	DIP8-pin	AQW454	AQW454A	AQW454AX	AQW454AZ	1 tube contains: 50 pcs. 1 batch contains: 500 pcs.	1,000 pcs

*Indicate the peak AC and DC values.

Note: The surface mount terminal indicator "A" and the packing style indicator "X" or "Z" are not marked on the relay.

RATING

1. Absolute maximum ratings (Ambient temperature: 25°C 77°F)

	Item	Symbol	AQW454(A)	Remarks
Input	LED forward current	I_F	50 mA	
	LED reverse voltage	V_R	5 V	
	Peak forward current	I_{FP}	1 A	$f = 100$ Hz, Duty factor = 0.1%
	Power dissipation	P_{in}	75 mW	
Output	Load voltage (peak AC)	V_L	400 V	
	Continuous load current	I_L	0.12 A (0.16 A)	A connection: Peak AC, DC () : for one 1b-circuit
	Peak load current	I_{peak}	0.36 A	A connection: 100 ms (1 shot), $V_L = DC$
	Power dissipation	P_{out}	800 mW	
Total power dissipation		P_T	850 mW	
I/O isolation voltage		V_{iso}	1,500 V AC	Between input and output/between contact sets
Temperature limits	Operating	T_{opr}	-40°C to +85°C -40°F to +185°F	Non-condensing at low temperatures
	Storage	T_{stg}	-40°C to +100°C -40°F to +212°F	

HE 2 Form B (AQW454)

2. Electrical characteristics (Ambient temperature: 25°C 77°F)

Item		Symbol	AQW454(A)	Condition
Input	LED operate (OFF) current	Typical	0.9 mA	$I_L = \text{Max.}$
		Maximum	3 mA	
	LED reverse (ON) current	Minimum	0.4 mA	$I_L = \text{Max.}$
		Typical	0.8 mA	
LED dropout voltage	Typical	V_F	1.25 V (1.14 V at $I_F = 5 \text{ mA}$)	$I_F = 50 \text{ mA}$
	Maximum		1.5 V	
Output	On resistance	Typical	11 Ω	$I_F = 0 \text{ mA}$ $I_L = \text{Max.}$ Within 1 s on time
		Maximum	16 Ω	
	Off state leakage current	Maximum	1 μA	$I_F = 5 \text{ mA}$ $V_L = \text{Max.}$
Transfer characteristics	Operate (OFF) time*	Typical	1.2 ms	$I_F = 0 \text{ mA} \rightarrow 5 \text{ mA}$ $I_L = \text{Max.}$
		Maximum	2 ms	
	Reverse (ON) time*	Typical	0.36 ms	$I_F = 5 \text{ mA} \rightarrow 0 \text{ mA}$ $I_L = \text{Max.}$
		Maximum	1 ms	
	I/O capacitance	Typical	C_{iso}	0.8 pF
Maximum		1.5 pF		
Initial I/O isolation resistance	Minimum	R_{iso}	1,000 M Ω	500 V DC

*Operate/Reverse time

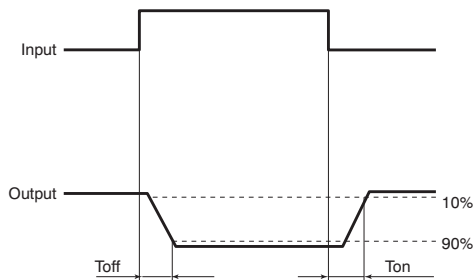

RECOMMENDED OPERATING CONDITIONS

Please obey the following conditions to ensure proper relay operation and resetting.

Item	Symbol	Recommended value	Unit
Input LED current	I_F	5	mA

- For Dimensions, see page 61.
- For Schematic and Wiring Diagrams, see page 66.
- For Cautions for Use, see page 71.
- These products are not designed for automotive use.

If you are considering to use these products for automotive applications, please contact your local Panasonic technical representative.

For more information, see page 80.

REFERENCE DATA

1. Load current vs. ambient temperature characteristics

Allowable ambient temperature: -40°C to $+85^\circ\text{C}$
 -40°F to $+185^\circ\text{F}$

When using 2 channels

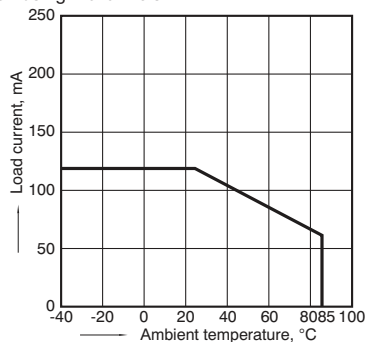

2. On resistance vs. ambient temperature characteristics

Measured portion: between terminals 5 and 6, 7 and 8; LED current: 0 mA; Load voltage: 400 V (DC); Continuous load current: 120 mA (DC)

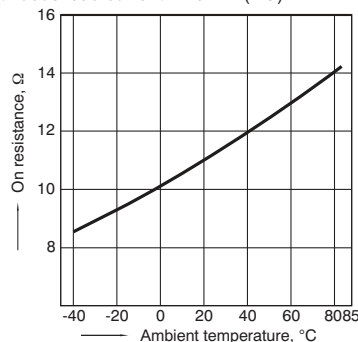

3. Operate (OFF) time vs. ambient temperature characteristics

LED current: 5 mA; Load voltage: 400 V (DC); Continuous load current: 120 mA (DC)

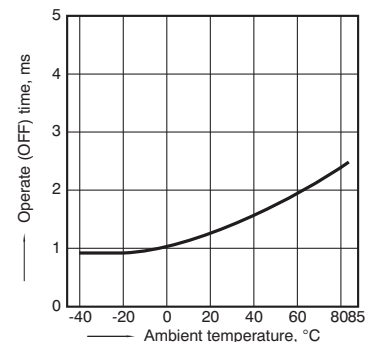

HE 2 Form B (AQW454)

4. Reverse (ON) time vs. ambient temperature characteristics

LED current: 5 mA; Load voltage: 400 V (DC);
Continuous load current: 120 mA (DC)

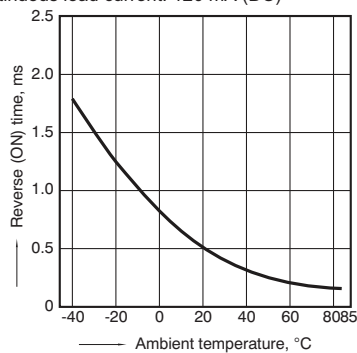

5. LED operate (OFF) current vs. ambient temperature characteristics

Load voltage: 400 V (DC);
Continuous load current: 120 mA (DC)

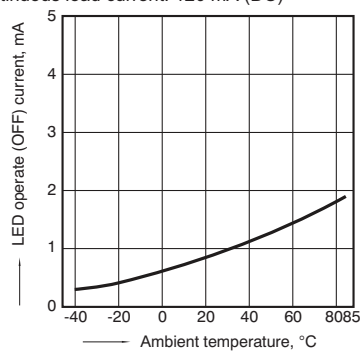

6. LED reverse (ON) current vs. ambient temperature characteristics

Load voltage: 400 V (DC);
Continuous load current: 120 mA (DC)

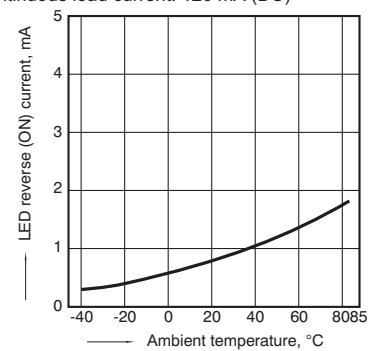

7. LED dropout voltage vs. ambient temperature characteristics

LED current: 5 to 50 mA

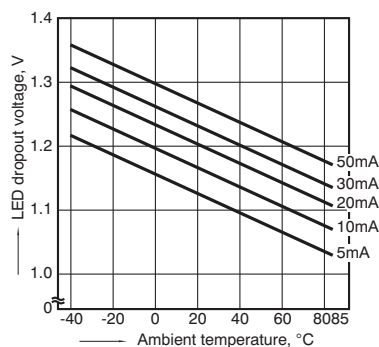

8. Current vs. voltage characteristics of output at MOS portion

Measured portion: between terminals 5 and 6,
7 and 8; Ambient temperature: 25°C 77°F

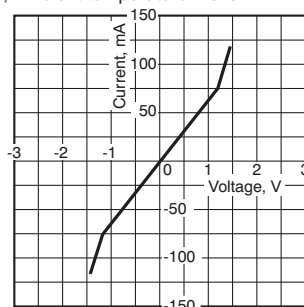

9. Off state leakage current vs. load voltage characteristics

Measured portion: between terminals 5 and 6,
7 and 8; Ambient temperature: 25°C 77°F

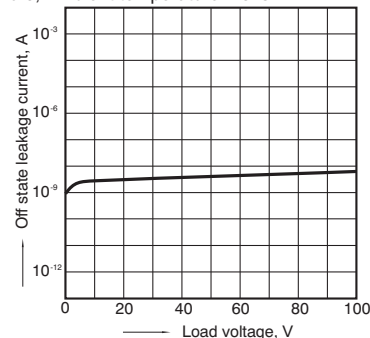

10. Operate (OFF) time vs. LED forward current characteristics

Measured portion: between terminals 5 and 6, 7 and 8; Load voltage: 400 V (DC); Continuous load current: 120 mA (DC); Ambient temperature: 25°C 77°F

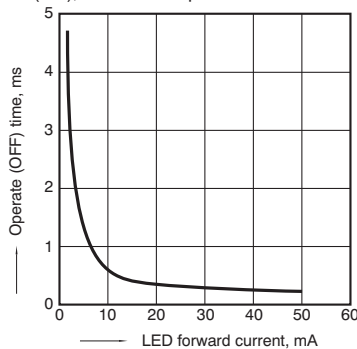

11. Reverse (ON) time vs. LED forward current characteristics

Measured portion: between terminals 5 and 6, 7 and 8; Load voltage: 400 V (DC); Continuous load current: 120 mA (DC); Ambient temperature: 25°C 77°F

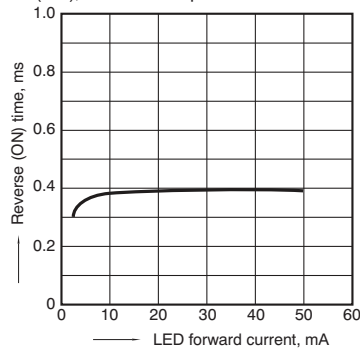

12. Output capacitance vs. applied voltage characteristics

Measured portion: between terminals 5 and 6, 7 and 8; Frequency: 1 MHz; Ambient temperature: 25°C 77°F

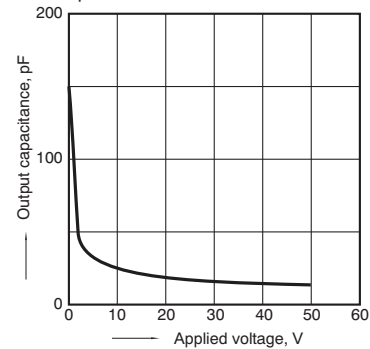

Panasonic

ideas for life



Both 1 Form A and 1 Form B contacts incorporated in a compact DIP8-pin with low on-resistance

PhotoMOS[®]
HE Form A & B
(AQW654)

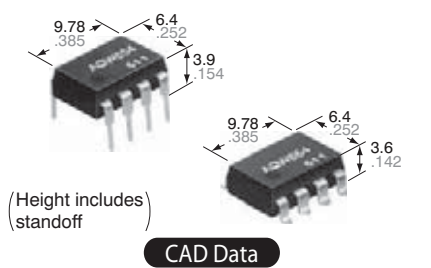

mm inch

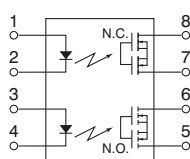

FEATURES

1. Applicable for 1 Form A 1 Form B use as well as two independent 1 Form A and 1 Form B use

2. Controls low-level analog signals
PhotoMOS relays feature extremely low closed-circuit offset voltage to enable control of low-level analog signals without distortion.

3. High sensitivity and low on-resistance

Can control max. 0.16 A load current with 5 mA input current. Low on-resistance of max. 11 Ω.

4. Low-level off state leakage current of max. 1 μA

TYPICAL APPLICATIONS

- High-speed inspection machines
- Data communication equipment
- Telephone equipment
- Sensing equipment

PhotoMOS

TYPES

	Output rating*		Package	Part No.				Packing quantity	
				Through hole terminal	Surface-mount terminal			Tube	Tape and reel
	Load voltage	Load current			Tube packing style	Tape and reel packing style			
AC/DC dual use	400 V	120 mA	DIP8-pin	AQW654	AQW654A	AQW654AX	AQW654AZ	1 tube contains: 50 pcs. 1 batch contains: 500 pcs.	1,000 pcs

*Indicate the peak AC and DC values.

Note: The surface mount terminal indicator "A" and the packing style indicator "X" or "Z" are not marked on the relay.

RATING

1. Absolute maximum ratings (Ambient temperature: 25°C 77°F)

	Item	Symbol	AQW654(A)	Remarks
Input	LED forward current	I _F	50 mA	
	LED reverse voltage	V _R	5 V	
	Peak forward current	I _{FP}	1 A	f = 100 Hz, Duty factor = 0.1%
	Power dissipation	P _{in}	75 mW	
Output	Load voltage (peak AC)	V _L	400 V	
	Continuous load current	I _L	0.12A (0.16 A)	Peak AC, DC () : in case of using only 1 channel
	Peak load current	I _{peak}	0.36 A	A connection: 100 ms (1 shot), V _L = DC
	Power dissipation	P _{out}	800 mW	
Total power dissipation		P _T	850 mW	
I/O isolation voltage		V _{iso}	1,500 V AC	Between input and output/between contact sets
Temperature limits	Operating	T _{opr}	-40°C to +85°C -40°F to +185°F	Non-condensing at low temperatures
	Storage	T _{stg}	-40°C to +100°C -40°F to +212°F	

HE Form A & B (AQW654)

2. Electrical characteristics (Ambient temperature: 25°C 77°F)

Item		Symbol	AQW654(A)	Remarks
Input	LED operate current	Typical	I_{Fon} (N.O.)	0.9 mA
		Maximum	I_{Foff} (N.C.)	3 mA
	LED reverse current	Minimum	I_{Foff} (N.O.)	0.4 mA
		Typical	I_{Fon} (N.C.)	0.8 mA
LED dropout voltage	Typical	V_F	1.25 V (1.14 V at $I_F = 5$ mA)	
	Maximum		1.5 V	$I_F = 50$ mA
Output	On resistance	Typical	R_{On}	11 Ω
		Maximum		16 Ω
	Off state leakage current	Maximum	I_{Leak}	1 μ A
Transfer characteristics	Operate time*	Typical	T_{On} (N.O.)	0.8 ms (N.O.) 1.2 ms (N.C.)
		Maximum		T_{Off} (N.C.)
	Reverse time*	Typical	T_{Off} (N.O.)	0.04 ms (N.O.) 0.36 ms (N.C.)
		Maximum		T_{On} (N.C.)
	I/O capacitance	Typical	C_{iso}	0.8 pF
		Maximum		1.5 pF
Initial I/O isolation resistance	Minimum	R_{iso}	1,000 M Ω	

*Operate/Reverse time

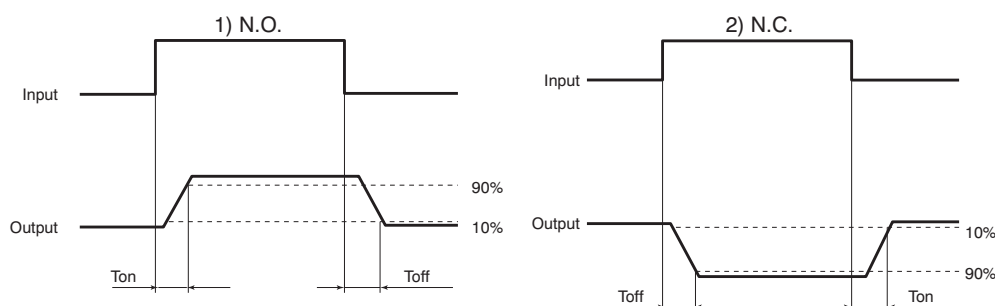

RECOMMENDED OPERATING CONDITIONS

Please obey the following conditions to ensure proper relay operation and resetting.

Item	Symbol	Recommended value	Unit
Input LED current	I_F	5	mA

■ For Dimensions, see page 61.

■ For Schematic and Wiring Diagrams, see page 66.

■ For Cautions for Use, see page 71.

■ These products are not designed for automotive use.

If you are considering to use these products for automotive applications, please contact your local Panasonic technical representative.

For more information, see page 80.

REFERENCE DATA

1. Load current vs. ambient temperature characteristics

Allowable ambient temperature: -40°C to +85°C
-40°F to +185°F

When using 2 channels

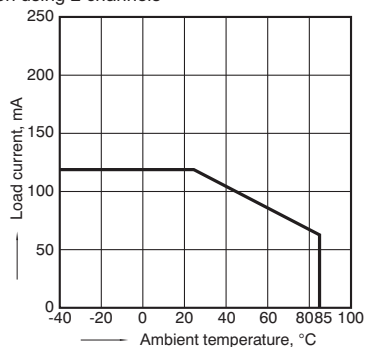

2. On resistance vs. ambient temperature characteristics

Measured portion: between terminals 5 and 6, 7 and 8; LED current: 5 mA; Load voltage: 400 V (DC); Continuous load current: 120 mA (DC)

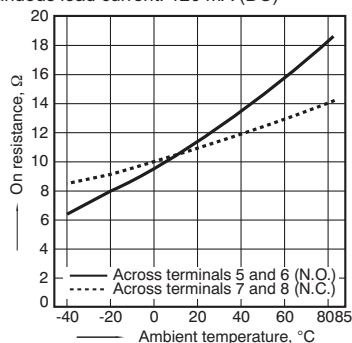

3. Operate time vs. ambient temperature characteristics

LED current: 5 mA; Load voltage: 400 V (DC); Continuous load current: 120 mA (DC)

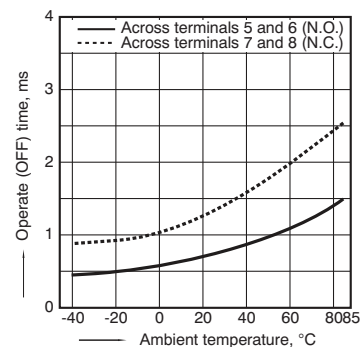

HE Form A & B (AQW654)

4. Reverse time vs. ambient temperature characteristics

LED current: 5 mA;
Load voltage: 400 V (DC);
Continuous load current: 120 mA (DC)

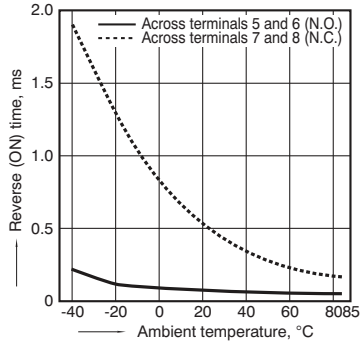

5. LED operate current vs. ambient temperature characteristics

Load voltage: 400 V (DC);
Continuous load current: 120 mA (DC)

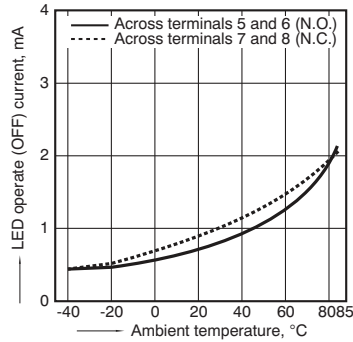

6. LED reverse current vs. ambient temperature characteristics

Load voltage: 400 V (DC);
Continuous load current: 120 mA (DC)

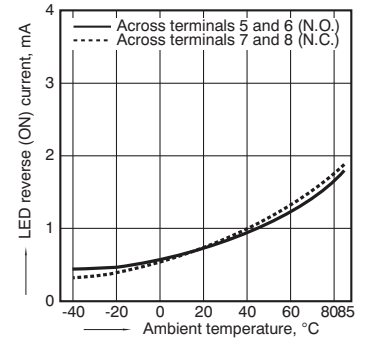

7. LED dropout voltage vs. ambient temperature characteristics

LED current: 5 to 50 mA

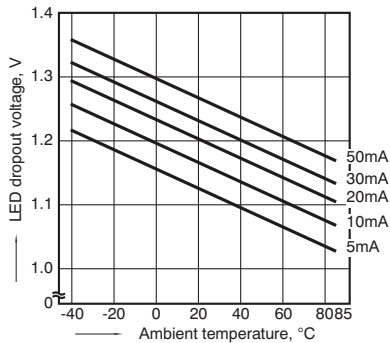

8. Current vs. voltage characteristics of output at MOS portion

Measured portion: between terminals 5 and 6, 7 and 8; Ambient temperature: 25°C 77°F

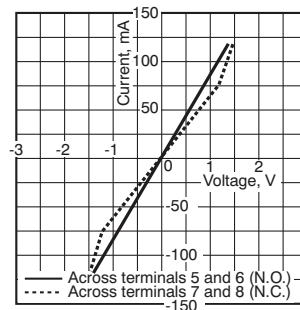

9. Off state leakage current vs. load voltage characteristics

Measured portion: between terminals 5 and 6, 7 and 8; Ambient temperature: 25°C 77°F

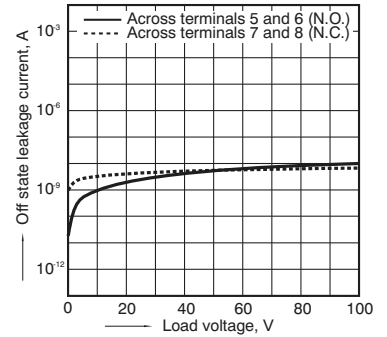

10. Operate time vs. LED forward current characteristics

Measured portion: between terminals 5 and 6, 7 and 8;
Load voltage: 400 V (DC); Continuous load current:
120 mA (DC); Ambient temperature: 25°C 77°F

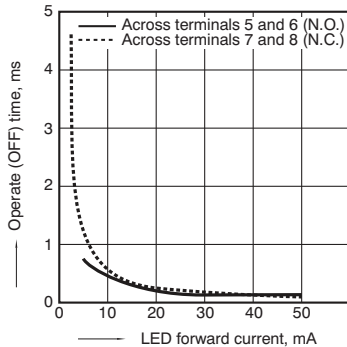

11. Reverse time vs. LED forward current characteristics

Measured portion: between terminals 5 and 6, 7 and 8;
Load voltage: 400 V (DC); Continuous load current:
120 mA (DC); Ambient temperature: 25°C 77°F

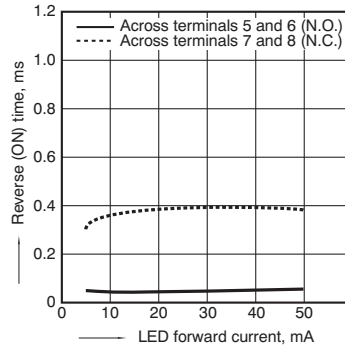

12. Output capacitance vs. applied voltage characteristics

Measured portion: between terminals 5 and 6, 7 and 8;
Frequency: 1 MHz;
Ambient temperature: 25°C 77°F

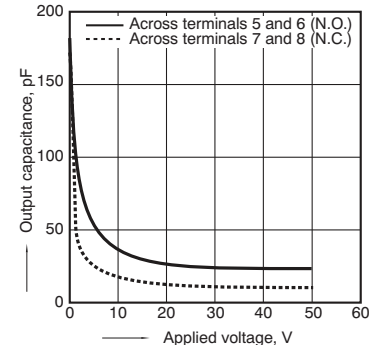

Panasonic

ideas for life



DIP6-pin type
with wide variation
Low on-resistance

PhotoMOS[®]
HF 1 Form A
(AQV10○, 20○)

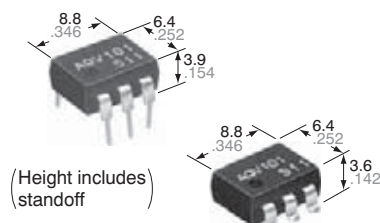

CAD Data

FEATURES

- Controls low-level analog signals**
PhotoMOS relays feature extremely low closed-circuit offset voltage to enable control of low-level analog signals without distortion.
- Controlled with low-level input signals**
- AC/DC dual use type and DC only type available.**

TYPICAL APPLICATIONS

- High-speed inspection machines
- Telephone equipment
- Data communication equipment
- Computers

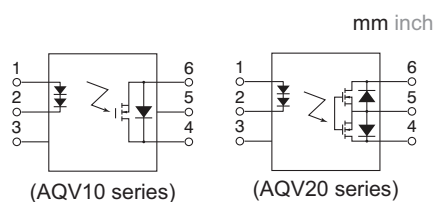

TYPES

1. DC type (AQV10 series)

	Output rating*		Package	Part No.				Packing quantity	
				Through hole terminal	Surface-mount terminal		Tube	Tape and reel	
	Load voltage	Load current			Tube packing style				Tape and reel packing style
DC only	40 V	700 mA	DIP6-pin	AQV101	AQV101A	AQV101AX	AQV101AZ	1 tube contains: 50 pcs. 1 batch contains: 500 pcs.	1,000 pcs
	60 V	600 mA		AQV102	AQV102A	AQV102AX	AQV102AZ		
	250 V	300 mA		AQV103	AQV103A	AQV103AX	AQV103AZ		
	400 V	180 mA		AQV104	AQV104A	AQV104AX	AQV104AZ		

*Indicate the peak AC and DC values.

Note: The surface mount terminal indicator "A" and the packing style indicator "X" or "Z" are not marked on the relay.

2. AC/DC type (AQV20 series)

	Output rating*		Package	Part No.				Packing quantity	
				Through hole terminal	Surface-mount terminal		Tube	Tape and reel	
	Load voltage	Load current			Tube packing style				Tape and reel packing style
AC/DC dual use	40 V	500 mA	DIP6-pin	AQV201	AQV201A	AQV201AX	AQV201AZ	1 tube contains: 50 pcs. 1 batch contains: 500 pcs.	1,000 pcs
	60 V	400 mA		AQV202	AQV202A	AQV202AX	AQV202AZ		
	250 V	200 mA		AQV203	AQV203A	AQV203AX	AQV203AZ		
	400 V	150 mA		AQV204	AQV204A	AQV204AX	AQV204AZ		

*Indicate the peak AC and DC values.

Note: The surface mount terminal indicator "A" and the packing style indicator "X" or "Z" are not marked on the relay.

HF 1 Form A (AQV10○, 20○)

RATING

1. DC type

1) Absolute maximum ratings (Ambient temperature: 25°C 77°F)

Item	Symbol	AQV101(A)	AQV102(A)	AQV103(A)	AQV104(A)	Remarks	
Input	LED forward current	I _F	50 mA				
	LED reverse voltage	V _R	10 V				
	Peak forward current	I _{FP}	1 A				f = 100 Hz, Duty factor = 0.1%
	Power dissipation	P _{in}	150 mW				
Output	Load voltage (DC)	V _L	40 V	60 V	250 V	400 V	
	Continuous load current (DC)	I _L	0.7 A	0.6 A	0.3 A	0.18 A	
	Peak load current	I _{peak}	1.8 A	1.5 A	0.6 A	0.5 A	100 ms (1 shot)
	Power dissipation	P _{out}	360 mW				
Total power dissipation	P _T	410 mW					
I/O isolation voltage	V _{iso}	1,500 V (AC)					
Temperature limits	Operating	T _{opr}	-40°C to +85°C -40°F to +185°F				Non-condensing at low temperatures
	Storage	T _{stg}	-40°C to +100°C -40°F to +212°F				

2) Electrical characteristics (Ambient temperature: 25°C 77°F)

Item	Symbol	AQV101(A)	AQV102(A)	AQV103(A)	AQV104(A)	Condition	
Input	LED operate current	Typical	2.3 mA				I _L = Max.
		Maximum	5 mA				
	LED turn off current	Minimum	0.8 mA				I _L = Max.
		Typical	2.2 mA				
LED dropout voltage	Typical	2.3 V				I _F = 10 mA	
	Maximum	3 V					
Output	On resistance	Typical	0.3 Ω	0.37 Ω	2.7 Ω	6.3 Ω	I _F = 10 mA I _L = Max. Within 1 s on time
		Maximum	0.5 Ω	0.7 Ω	4 Ω	8 Ω	
	Off state leakage current	Maximum	1 μA				I _F = 0 mA, V _L = Max.
Transfer characteristics	Turn on time*	Typical	0.23 ms	0.22 ms	0.13 ms	0.09 ms	I _F = 10 mA I _L = Max.
		Maximum	1 ms				
	Turn off time*	Typical	0.07 ms			0.08 ms	I _F = 10 mA I _L = Max.
		Maximum	1 ms				
I/O capacitance	Typical	1.3 pF				f = 1 MHz V _S = 0 V	
	Maximum	3 pF					
Initial I/O isolation resistance	Minimum	1,000 MΩ				500 V DC	

2. AC/DC type

1) Absolute maximum ratings (Ambient temperature: 25°C 77°F)

Item	Symbol	Type of connection	AQV201(A)	AQV202(A)	AQV203(A)	AQV204(A)	Remarks	
Input	LED forward current	I _F	50 mA					
	LED reverse voltage	V _R	10 V					
	Peak forward current	I _{FP}	1 A				f = 100 Hz, Duty factor = 0.1%	
	Power dissipation	P _{in}	150 mW					
Output	Load voltage (peak AC)	V _L	40 V	60 V	250 V	400 V		
	Continuous load current	I _L	A	0.5 A	0.4 A	0.2 A	0.15 A	A connection: Peak AC, DC B, C connection: DC
			B	0.7 A	0.6 A	0.3 A	0.18 A	
			C	1.0 A	0.8 A	0.4 A	0.25 A	
	Peak load current	I _{peak}		1.8 A	1.5 A	0.6 A	0.5 A	A connection 100 ms (1 shot) V _L = DC
Power dissipation	P _{out}		360 mW					
Total power dissipation	P _T		410 mW					
I/O isolation voltage	V _{iso}		1,500 V AC					
Temperature limits	Operating	T _{opr}	-40°C to +85°C -40°F to +185°F				Non-condensing at low temperature	
	Storage	T _{stg}	-40°C to +100°C -40°F to +212°F					

HF 1 Form A (AQV10○, 20○)

2) Electrical characteristics (Ambient temperature: 25°C 77°F)

Item		Symbol	Type of connection	AQV201(A)	AQV202(A)	AQV203(A)	AQV204(A)	Remarks	
Input	LED operate current	Typical	I _{Fon}	2.4 mA				I _L = Max.	
		Maximum		5 mA					
	LED turn off current	Minimum	I _{Foff}	0.8 mA				I _L = Max.	
		Typical		2.2 mA					
LED dropout voltage	Typical	V _F	2.3 V				I _F = 10 mA		
	Maximum		3 V						
Output	On resistance	Typical	R _{on}	A	0.6 Ω	0.74 Ω	5.5 Ω	12.4 Ω	I _F = 10 mA I _L = Max. Within 1 s on time
		Maximum		1 Ω	1.4 Ω	8 Ω	16 Ω		
		Typical	R _{on}	B	0.3 Ω	0.37 Ω	2.7 Ω	6.2 Ω	I _F = 10 mA I _L = Max. Within 1 s on time
		Maximum		0.5 Ω	0.7 Ω	4 Ω	8 Ω		
	Off state leakage current	Maximum	I _{Leak}	—	1 μA				I _F = 0 mA, V _L = Max.
		Initial I/O isolation resistance			Minimum	R _{iso}	1,000 MΩ		
Transfer characteristics	Turn on time*	Typical	T _{on}	—	0.38 ms	0.41 ms	0.21 ms	0.18 ms	I _F = 10 mA I _L = Max.
		Maximum			1 ms				
	Turn off time*	Typical	T _{off}	—	0.08 ms		0.07 ms		I _F = 10 mA I _L = Max.
		Maximum			1 ms				
	I/O capacitance	Typical	C _{iso}	—	1.3 pF				f = 1 MHz V _B = 0 V
		Maximum			3 pF				
Initial I/O isolation resistance	Minimum	R _{iso}	—	1,000 MΩ				500 V DC	

*Turn on/Turn off time

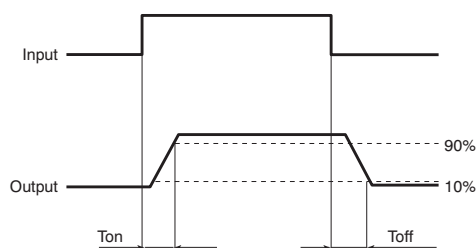

RECOMMENDED OPERATING CONDITIONS

Please obey the following conditions to ensure proper relay operation and resetting.

Item	Symbol	Recommended value	Unit
Input LED current	I _F	10	mA

■ For Dimensions, see page 60.

■ For Schematic and Wiring Diagrams, see page 64.

■ For Cautions for Use, see page 71.

■ These products are not designed for automotive use.

If you are considering to use these products for automotive applications, please contact your local Panasonic technical representative.

For more information, see page 80.

HF 1 Form A (AQV10○, 20○)

REFERENCE DATA

13-(1) Load current vs. ambient temperature characteristics (DC type)

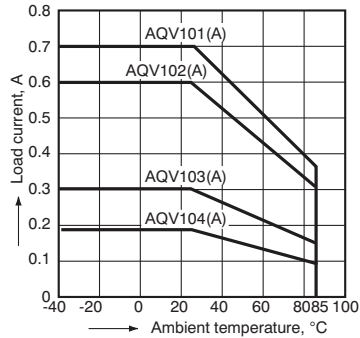
Allowable ambient temperature: -40°C to +85°C
-40°F to +185°F

1.-(2) Load current vs. ambient temperature characteristics (AC/DC type)

Allowable ambient temperature: -40°C to +85°C
-40°F to +185°F

Type of connection: A

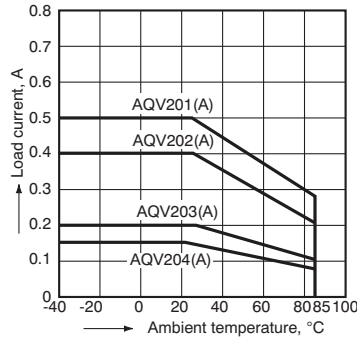

14-(1) On resistance vs. ambient temperature characteristics (DC type: AQV101, AQV102)

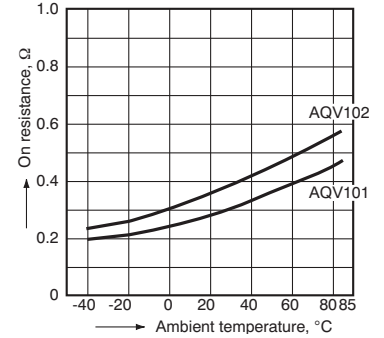
LED current: 10 mA;
Continuous load current: Max. (DC)

2.-(2) On resistance vs. ambient temperature characteristics (DC type: AQV103, AQV104)

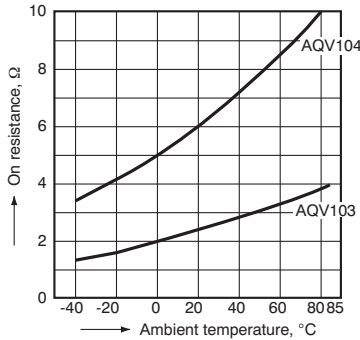
LED current: 10 mA;
Continuous load current: Max. (DC)

2.-(3) On resistance vs. ambient temperature characteristics (AC/DC type: AQV201, AQV202)

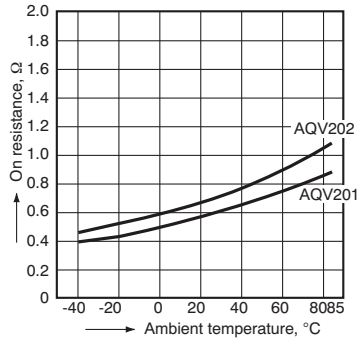
Measured portion: between terminals 4 and 6;
LED current: 10 mA;
Continuous load current: Max. (DC)

2.-(4) On resistance vs. ambient temperature characteristics (AC/DC type: AQV203, AQV204)

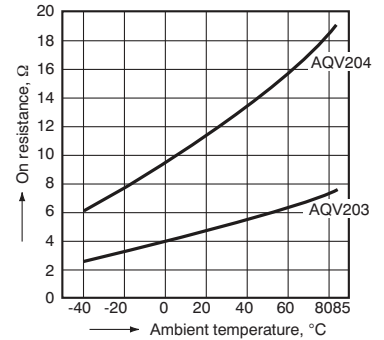
Measured portion: between terminals 4 and 6;
LED current: 10 mA;
Continuous load current: Max. (DC)

15-(1) Turn on time vs. ambient temperature characteristics (DC type)

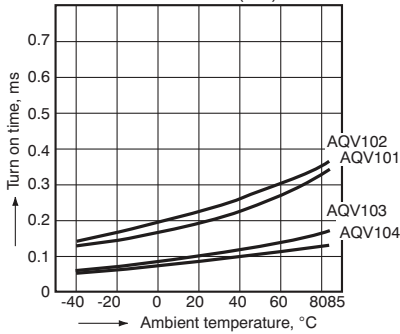
LED current: 10 mA;
Load voltage: Max. (DC);
Continuous load current: Max. (DC)

3.-(2) Turn on time vs. ambient temperature characteristics (AC/DC type)

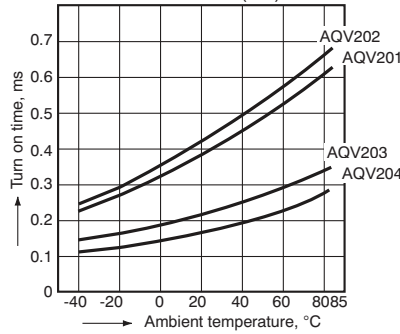
LED current: 10 mA;
Load voltage: Max. (DC);
Continuous load current: Max. (DC)

16-(1) Turn off time vs. ambient temperature characteristics (DC type)

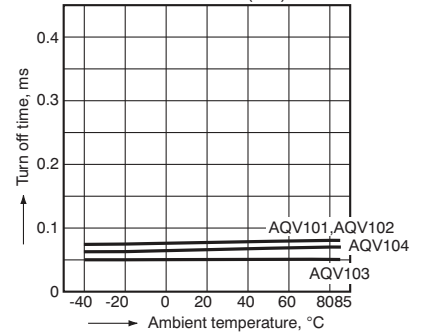
LED current: 10 mA;
Load voltage: Max. (DC);
Continuous load current: Max. (DC)

4.-(2) Turn off time vs. ambient temperature characteristics (AC/DC type)

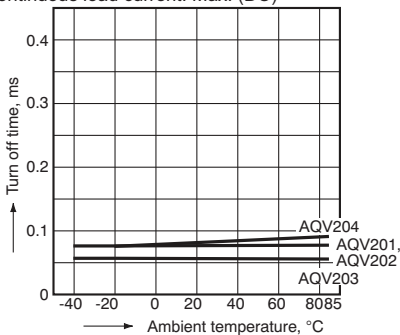
LED current: 10 mA; Load voltage: Max. (DC);
Continuous load current: Max. (DC)

17-(1) LED operate/turn off current vs. ambient temperature characteristics (DC type)

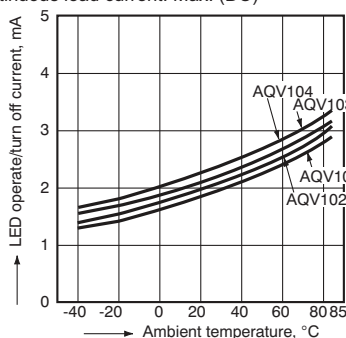
Load voltage: Max. (DC);
Continuous load current: Max. (DC)

5.-(2) LED operate/turn off current vs. ambient temperature characteristics (AC/DC type)

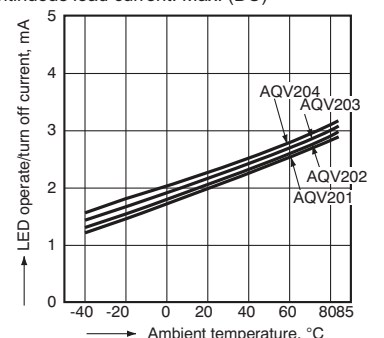
Load voltage: Max. (DC);
Continuous load current: Max. (DC)

HF 1 Form A (AQV10○, 20○)

18. LED dropout voltage vs. ambient temperature characteristics

Sample: AQV202

LED current: 10 to 50 mA

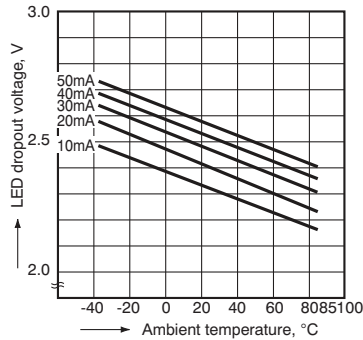

19-(1) Current vs. voltage characteristics of output at MOS portion (DC type)

Ambient temperature: 25°C 77°F

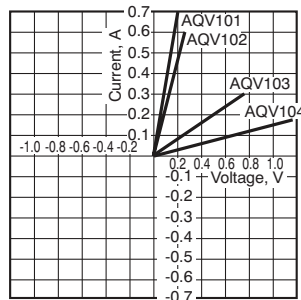

7.-(2) Current vs. voltage characteristics of output at MOS portion (AC/DC type)

Measured portion: between terminals 4 and 6;

Ambient temperature: 25°C 77°F

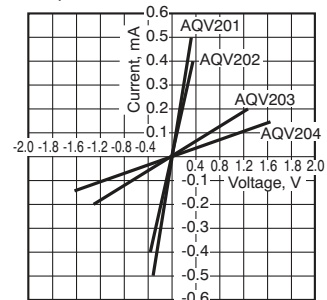

20. Off state leakage current vs. load voltage characteristics

Sample: AQV204;

Measured portion: between terminals 4 and 6;

Ambient temperature: 25°C 77°F

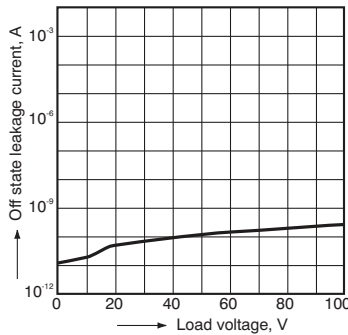

21-(1) Turn on time vs. LED forward current characteristics (DC type)

Load voltage: Max. (DC);

Continuous load current: Max. (DC);

Ambient temperature: 25°C 77°F

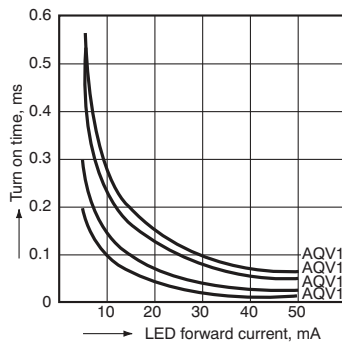

9.-(2) Turn on time vs. LED forward current characteristics (AC/DC type)

Measured portion: between terminals 4 and 6;

Load voltage: Max. (DC);

Continuous load current: Max. (DC);

Ambient temperature: 25°C 77°F

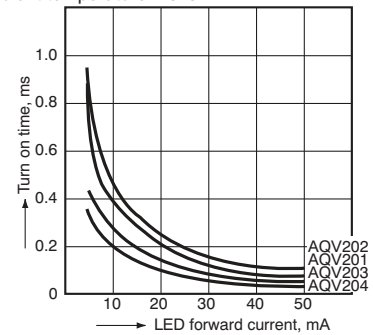

22-(1) Turn off time vs. LED forward current characteristics (DC type)

Load voltage: Max. (DC);

Continuous load current: Max. (DC);

Ambient temperature: 25°C 77°F

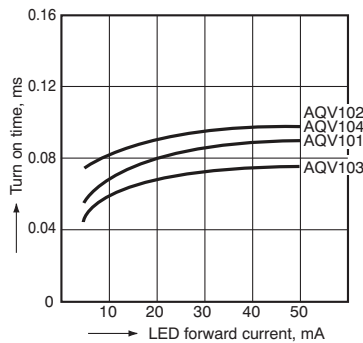

10.-(2) Turn off time vs. LED forward current characteristics (AC/DC type)

Measured portion: between terminals 4 and 6;

Load voltage: Max. (DC);

Continuous load current: Max. (DC);

Ambient temperature: 25°C 77°F

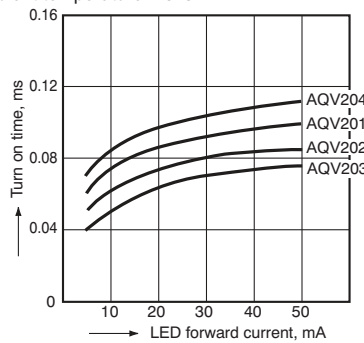

23-(1) Output capacitance vs. applied voltage characteristics (DC type)

Frequency: 1 MHz;

Ambient temperature: 25°C 77°F

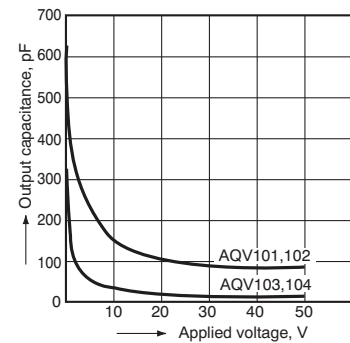

11.-(2) Output capacitance vs. applied voltage characteristics (AC/DC type)

Measured portion: between terminals 4 and 6;

Frequency: 1 MHz;

Ambient temperature: 25°C 77°F

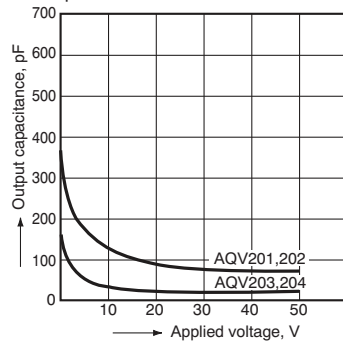

Panasonic

ideas for life



DIP6-pin type
featuring high sensitivity

PhotoMOS[®]
HS 1 Form A
(AQV234)

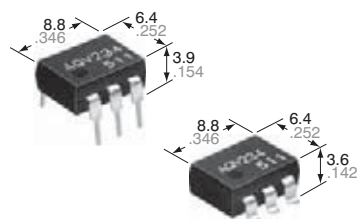

CAD Data

mm inch

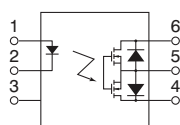

FEATURES

1. High sensitivity

LED operate current: 0.31mA (typ.)

Recommended LED input current: 2mA

2. Low-level off state leakage current of max. 1 μ A

3. Controls low-level analog signals

PhotoMOS relays feature extremely low closed-circuit offset voltage to enable control of low-level analog signals without distortion.

TYPICAL APPLICATIONS

1. High-speed inspection machines

Scanner, IC checker, Board tester, etc.

2. Telephone and data communication equipment

PhotoMOS

TYPES

	Output rating*		Package	Part No.				Packing quantity	
				Through hole terminal	Surface-mount terminal		Tube	Tape and reel	
	Load voltage	Load current			Tube packing style				Tape and reel packing style
					Picked from the 1/2/3-pin side	Picked from the 4/5/6-pin side			
AC/DC dual use	400 V	120 mA	DIP6-pin	AQV234	AQV234A	AQV234AX	AQV234AZ	1 tube contains: 50 pcs. 1 batch contains: 500 pcs.	1,000 pcs.

*Indicate the peak AC and DC values.

Note: The surface mount terminal indicator "A" and the packing style indicator "X" or "Z" are not marked on the relay.

RATING

1. Absolute maximum ratings (Ambient temperature: 25°C 77°F)

Item		Symbol	Type of connection	AQV234(A)	Remarks	
Input	LED forward current	I_F		50 mA		
	LED reverse voltage	V_R		5 V		
	Peak forward current	I_{FP}		1 A	$f = 100 \text{ Hz}$, Duty factor = 0.1%	
	Power dissipation	P_{in}		75 mW		
Output	Load voltage (Peak AC)	V_L		400 V		
	Continuous load current	I_L		A	0.12 A	A connection: Peak AC, DC B, C connection: DC
				B	0.13 A	
				C	0.15 A	
	Peak load current	I_{peak}			0.3 A	A connection: 100 ms (1 shot), $V_L = \text{DC}$
Power dissipation	P_{out}		500 mW			
Total power dissipation		P_T		550 mW		
I/O isolation voltage		V_{iso}		1,500 V AC		
Temperature limits	Operating	T_{opr}		-40°C to +85°C -40°F to +185°F	Non-condensing at low temperature	
	Storage	T_{stg}		-40°C to +100°C -40°F to +212°F		

HS 1 Form A (AQV234)

2. Electrical characteristics (Ambient temperature: 25°C 77°F)

Item		Symbol	Type of connection	AQV234(A)	Remarks	
Input	LED operate current	Typical	I _{Fon}	—	0.31 mA	$\Delta I_F/\Delta t$ Min. 100 μ A/s I _L = Max.
		Maximum				
	LED turn off current	Minimum	I _{Foff}	—	0.1 mA	
		Typical				
LED dropout voltage	Typical	V _F	—	1.25 V (1.1 V at I _F = 2 mA)		
	Maximum			1.5 V		
Output	On resistance	Typical	R _{on}	A	30 Ω	I _F = 2 mA, I _L = Max. Within 1 s on time
		Maximum			50 Ω	
		Typical	R _{on}	B	22.5 Ω	
		Maximum			25 Ω	
	Typical	R _{on}	C	11.3 Ω	I _F = 2 mA, I _L = Max. Within 1 s on time	
	Maximum			12.5 Ω		
Off state leakage current	Maximum	I _{Leak}	—	1 μ A	I _F = 0 mA, V _L = Max.	
Transistor characteristics	Turn on time*	Typical	T _{on}	—	0.89 ms	I _F = 2 mA I _L = Max.
		Maximum			2 ms	
	Turn off time*	Typical	T _{off}	—	0.22 ms	I _F = 2 mA I _L = Max.
		Maximum			1 ms	
	I/O capacitance	Typical	C _{iso}	—	0.8 pF	f = 1 MHz
Maximum		1.5 pF			V _B = 0 V	
Initial I/O isolation resistance	Minimum	R _{iso}	—	1,000 M Ω	500 V DC	

*Turn on/Turn off time

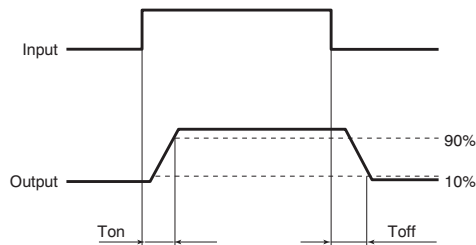

RECOMMENDED OPERATING CONDITIONS

Please obey the following conditions to ensure proper relay operation and resetting.

Item	Symbol	Recommended value	Unit
Input LED current	I _F	2	mA

■ For Dimensions, see page 60.

■ For Schematic and Wiring Diagrams, see page 65.

■ For Cautions for Use, see page 71.

■ These products are not designed for automotive use.

If you are considering to use these products for automotive applications, please contact your local Panasonic technical representative.

For more information, see page 80.

REFERENCE DATA

1. Load current vs. ambient temperature characteristics

Allowable ambient temperature: -40°C to +85°C
-40°F to +185°F

Type of connection: A

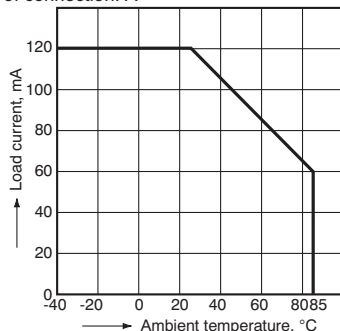

2. On resistance vs. ambient temperature characteristics

Measured portion: between terminals 4 and 6;
LED current: 2 mA; Load voltage: 400 V (DC);
Continuous load current: 120 mA (DC)

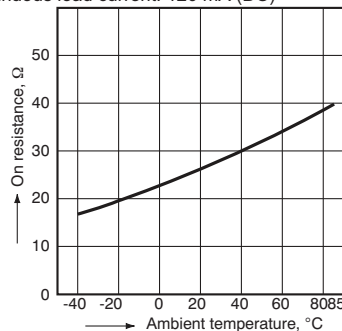

3. Turn on time vs. ambient temperature characteristics

LED current: 2 mA;
Load voltage: 400 V (DC);
Continuous load current: 120 mA (DC)

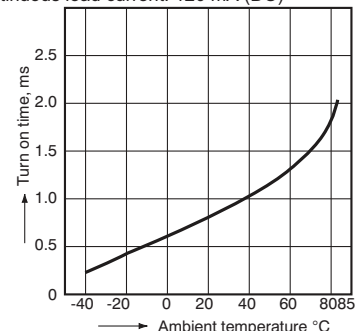

HS 1 Form A (AQV234)

4. Turn off time vs. ambient temperature characteristics

LED current: 2 mA; Load voltage: 400 V (DC);
Continuous load current: 120 mA (DC)

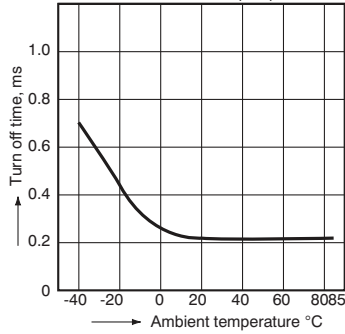

5. LED operate current vs. ambient temperature characteristics

Load voltage: 400 V (DC);
Continuous load current: 120 mA (DC)

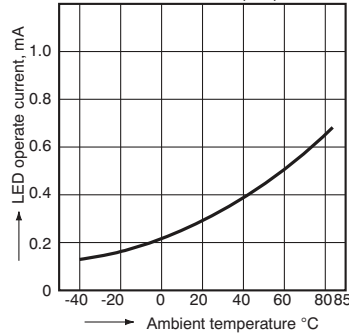

6. LED turn off current vs. ambient temperature characteristics

Load voltage: 400 V (DC);
Continuous load current: 120 mA (DC)

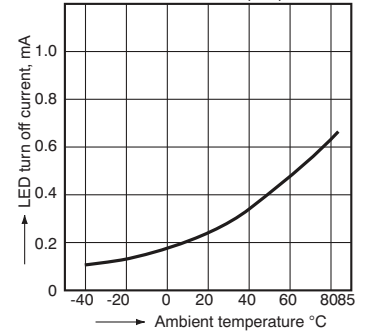

7. LED dropout voltage vs. ambient temperature characteristics

LED current: 2 to 50 mA

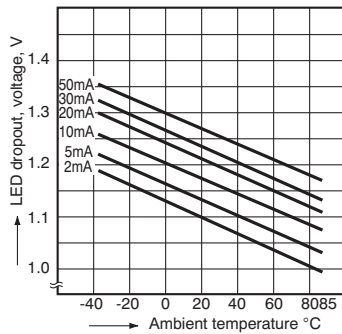

8. Current vs. voltage characteristics of output at MOS portion

Measured portion: between terminals 4 and 6;
Ambient temperature: 25°C 77°F

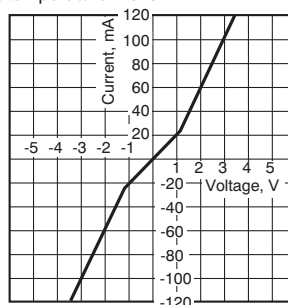

9. Off state leakage current vs. load voltage characteristics

Measured portion: between terminals 4 and 6;
Ambient temperature: 25°C 77°F

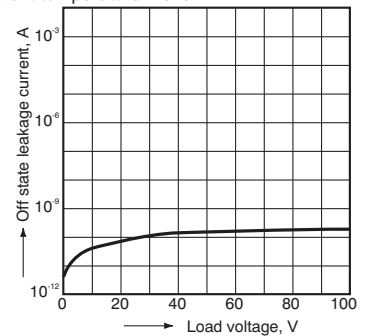

10. Turn on time vs. LED forward current characteristics

Measured portion: between terminals 4 and 6;
Load voltage: 400 V (DC); Continuous load current:
120 mA (DC); Ambient temperature: 25°C 77°F

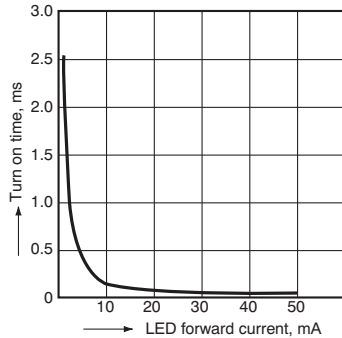

11. Turn off time vs. LED forward current characteristics

Measured portion: between terminals 4 and 6;
Load voltage: 400 V (DC); Continuous load current:
120 mA (DC); Ambient temperature: 25°C 77°F

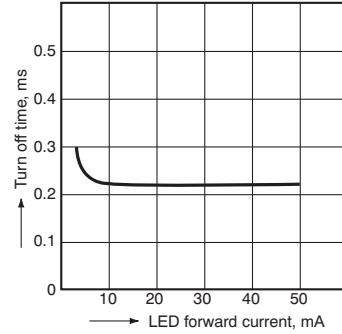

12. Output capacitance vs. applied voltage characteristics

Measured portion: between terminals 4 and 6;
Frequency: 1 MHz;
Ambient temperature: 25°C 77°F

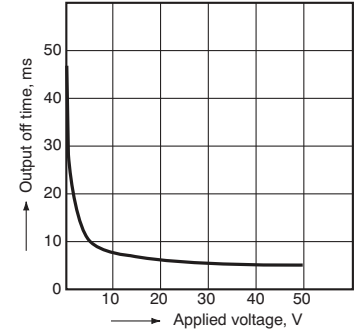

Panasonic

ideas for life

Recommended LED forward current 2 mA, High Sensitivity (Low current-consumption), Miniature SOP4-pin Type

**PhotoMOS®
HS SOP 1 Form A**



CAD Data

mm inch

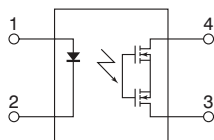

FEATURES

1. High sensitivity (Low current-consumption)

HS type PhotoMOS relays need less than half LED forward current of other types. This contributes to energy-saving working of equipment and longer operating life for battery.

Sensitivity comparison between HS type and GU type

In case of load voltage 60V type, SOP4-pin

		HS type (AQY232S)	GU type (AQY212S)
LED operate current	Typical	0.35 mA	0.9 mA
	Maximum	0.5 mA	3 mA
Recommended LED forward current		2 mA	5 mA

2. Small package (SOP4-pin)

3. 60 V, 350 V and 400 V load voltage types available

TYPICAL APPLICATIONS

Ideal for battery-powered devices that need to lengthen operating life.

Also recommended for power-economizing of testing equipment that uses many relays.

1. Security equipment

- Crime-preventing system: Surveillance camera, burglar alarm
- Disaster-preventing system: Fire alarm, heat/smoke sensor

2. Measuring instruments

3. Meters (watt-hour, gas, etc.)

4. Telecommunication equipment

5. Industrial equipment

TYPES

	Output rating*		Package	Part No.			Packing quantity	
	Load voltage	Load current		Tube packing style	Tape and reel packing style		Tube	Tape and reel
					Picked from the 1/2-pin side	Picked from the 3/4-pin side		
AC/DC dual use	60V	500mA	SOP4-pin	AQY232S	AQY232SX	AQY232SZ	1 tube contains: 100 pcs. 1 batch contains: 2,000 pcs.	1,000 pcs.
	350V	120mA		AQY230S	AQY230SX	AQY230SZ		
	400V	100mA		AQY234S	AQY234SX	AQY234SZ		

Note: For space reasons, the three initial letters of the part number "AQY", the surface mount terminal indicator "S" and the packing style indicator "X" or "Z" are not marked on the relay. (Ex. the label for product number AQY232SX is 232.)

* Indicate the peak AC and DC values.

Ratings and packages other than those given above are available by special order. Please contact our sales office in your area.

RATING

1. Absolute maximum ratings (Ambient temperature: 25°C 77°F)

Item		Symbol	AQY232S	AQY230S	AQY234S	Remarks
Input	LED forward current	I_F	50 mA			
	LED reverse voltage	V_R	5 V			
	Peak forward current	I_{FP}	1 A			$f = 100 \text{ Hz}$, Duty factor = 0.1%
	Power dissipation	P_{in}	75 mW			
Output	Load voltage (peak AC)	V_L	60 V	350 V	400 V	
	Continuous load current	I_L	0.5 A	0.12 A	0.1 A	Peak AC, DC
	Peak load current	I_{peak}	1.5 A	0.3 A	0.24 A	100ms (1 shot), $V_L = \text{DC}$
	Power dissipation	P_{out}	300 mW			
Total power dissipation		P_T	350 mW			
I/O isolation voltage		V_{iso}	1,500 V AC			
Operating temperature		T_{opr}	-40°C to +85°C -40°F to +185°F			Non-condensing at low temperatures
Storage temperature		T_{stg}	-40°C to +100°C -40°F to +212°F			

HS SOP 1 Form A

2. Electrical characteristics (Ambient temperature: 25°C 77°F)

Item			Symbol	AQY232S	AQY230S	AQY234S	Remarks
Input	LED operate current	Typical	I_{Fon}	0.35 mA			$\Delta I_F/\Delta t \geq \text{Min. } 100 \mu\text{A/s}$ $I_L = \text{Max.}$
		Maximum		0.5 mA			
	LED turn off current	Minimum	I_{Foff}	0.1 mA			$\Delta I_F/\Delta t \geq \text{Min. } 100 \mu\text{A/s}$ $I_L = \text{Max.}$
		Typical		0.3 mA			
LED dropout voltage	Typical	V_F	1.25 V (1.1 V at $I_F = 2 \text{ mA}$)			$I_F = 50 \text{ mA}$	
	Maximum		1.5 V				
Output	On resistance	Typical	R_{on}	0.85 Ω	19 Ω	27 Ω	$I_F = 2 \text{ mA}$ $I_L = \text{Max.}$ Within 1 s on time
		Maximum		2.5 Ω	25 Ω	35 Ω	
	Off state leakage current	Maximum	I_{Leak}	1 μA			$I_F = 0 \text{ mA}$ $V_L = \text{Max.}$
Transfer characteristics	Turn on time*	Typical	T_{on}	1.5 ms	1.2 ms	0.8 ms	$I_F = 2 \text{ mA}$ $I_L = \text{Max.}$
		Maximum		5 ms			
	Turn off time*	Typical	T_{off}	0.15 ms	0.1 ms	0.1 ms	$I_F = 2 \text{ mA}$ $I_L = \text{Max.}$
		Maximum		2 ms			
	I/O capacitance	Typical	C_{iso}	0.8 pF			$f = 1 \text{ MHz}$ $V_S = 0 \text{ V}$
		Maximum		1.5 pF			
Initial I/O isolation resistance	Minimum	R_{iso}	1,000 M Ω			500 V DC	

Note: Please refer to the schematic and wiring diagram for connection method.

*Turn on/Turn off time

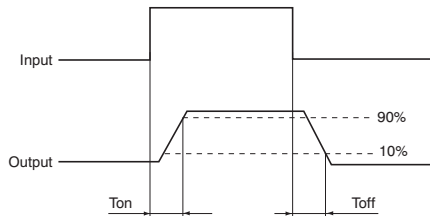

RECOMMENDED OPERATING CONDITIONS

Please obey the following conditions to ensure proper relay operation (turn on) and resetting (turn off).

Item	Symbol	Recommended value	Unit
Input LED current	I_F	2	mA

■ For Dimensions, see page 62.

■ For Schematic and Wiring Diagrams, see page 64.

■ For Cautions for Use, see page 71.

■ These products are not designed for automotive use.

If you are considering to use these products for automotive applications, please contact your local Panasonic technical representative.

For more information, see page 80.

REFERENCE DATA

1. Load current vs. ambient temperature characteristics

Allowable ambient temperature: -40°C to $+85^\circ\text{C}$
 -40°F to $+185^\circ\text{F}$

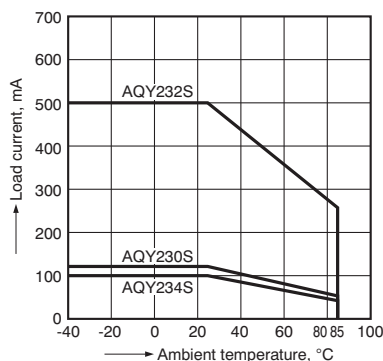

2. On resistance vs. ambient temperature characteristics

Measured portion: between terminals 3 and 4;
LED current: 2 mA; Load voltage: Max. (DC);
Continuous load current: Max. (DC)

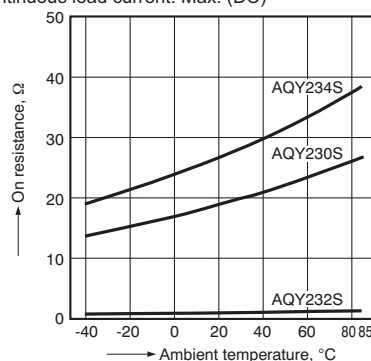

3. Turn on time vs. ambient temperature characteristics

LED current: 2 mA; Load voltage: Max. (DC);
Continuous load current: Max. (DC)

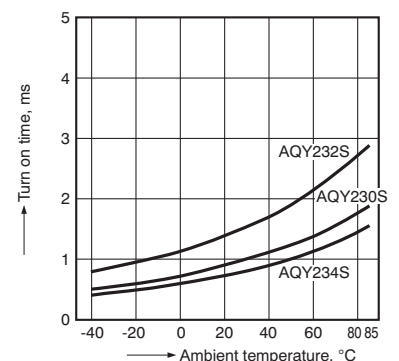

HS SOP 1 Form A

4. Turn off time vs. ambient temperature characteristics

LED current: 2 mA; Load voltage: Max. (DC); Continuous load current: Max. (DC)

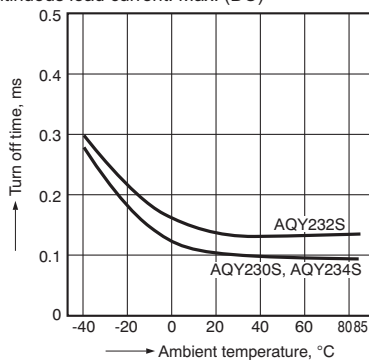

5. LED operate current vs. ambient temperature characteristics

Sample: All types; Load voltage: Max. (DC); Continuous load current: Max. (DC)

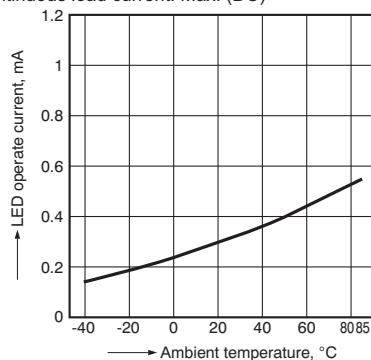

6. LED turn off current vs. ambient temperature characteristics

Sample: All types; Load voltage: Max. (DC); Continuous load current: Max. (DC)

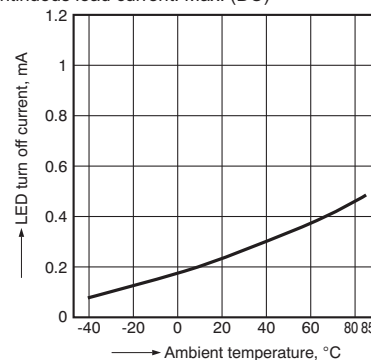

7. LED dropout voltage vs. ambient temperature characteristics

Sample: All types; LED current: 2 to 50 mA

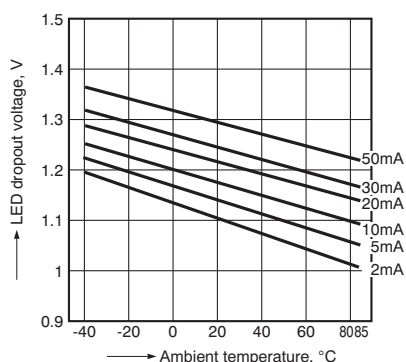

8-(1). Current vs. voltage characteristics of output at MOS portion

Measured portion: between terminals 3 and 4; Ambient temperature: 25°C 77°F

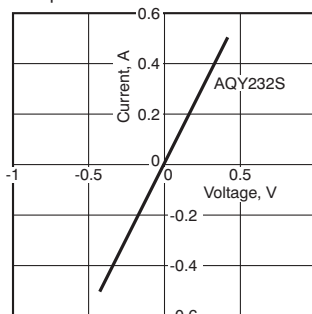

8-(2). Current vs. voltage characteristics of output at MOS portion

Measured portion: between terminals 3 and 4; Ambient temperature: 25°C 77°F

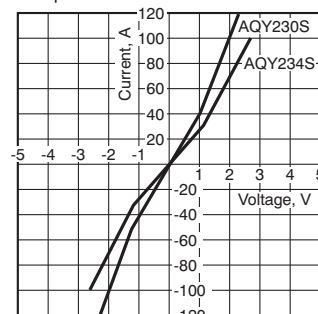

9. Off state leakage current vs. load voltage characteristics

Measured portion: between terminals 3 and 4; Ambient temperature: 25°C 77°F

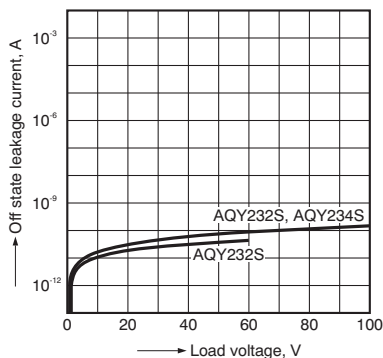

10. Turn on time vs. LED forward current characteristics

Measured portion: between terminals 3 and 4; Load voltage: Max. (DC); Continuous load current: Max. (DC); Ambient temperature: 25°C 77°F

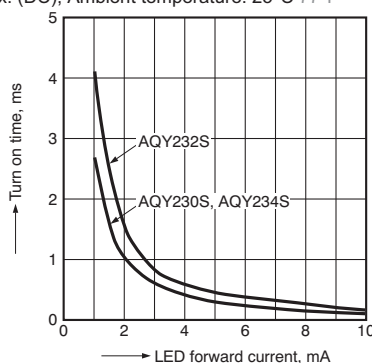

11. Turn off time vs. LED forward current characteristics

Measured portion: between terminals 3 and 4; Load voltage: Max. (DC); Continuous load current: Max. (DC); Ambient temperature: 25°C 77°F

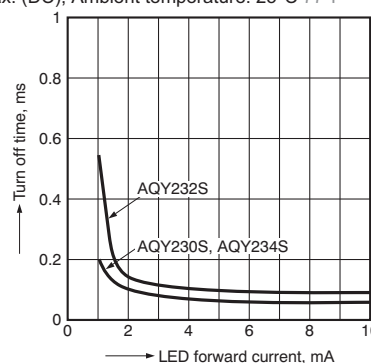

12. Output capacitance vs. applied voltage characteristics

Measured portion: between terminals 3 and 4; Frequency: 1 MHz (30 mVrms); Ambient temperature: 25°C 77°F

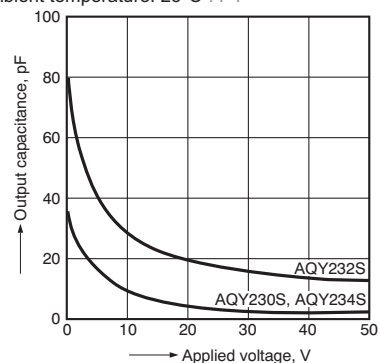

HS SOP 1 Form A

DIMENSIONS (Unit: mm inch)

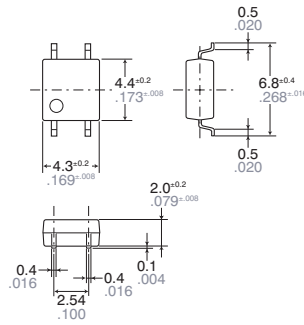

External dimensions

Terminal thickness $t = \pm 0.15 \pm .006$ General tolerance: $\pm 0.1 \pm .004$

Recommended mounting pad (Top view)

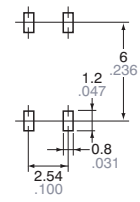
Tolerance: $\pm 0.1 \pm .004$

SCHEMATIC AND WIRING DIAGRAMS

E₁: Power source at input side; I_F: LED forward current; V_L: Load voltage; I_L: Load current

Schematic	Output configuration	Load	Wiring diagram
	1a	AC/DC	

PhotoMOS RELAYS CAUTIONS FOR USE

SAFETY WARNINGS

• Do not use the product under conditions that exceed the range of its specifications. It may cause overheating, smoke, or fire.

• Do not touch the recharging unit while the power is on. There is a danger of electrical shock. Be sure to turn off the power when performing mounting, maintenance, or repair operations on the relay (including connecting parts such as the terminal board and socket).

• Check the connection diagrams in the catalog and be sure to connect the terminals correctly. Erroneous connections could lead to unexpected operating errors, overheating, or fire.

1. Applying stress that exceeds the absolute maximum rating

If the voltage or current value for any of the terminals exceeds the absolute maximum rating, internal elements will deteriorate because of the overvoltage or overcurrent. In extreme cases, wiring may melt, or silicon P/N junctions may be destroyed.

Therefore, the circuit should be designed in such a way that the load never exceed the absolute maximum ratings, even momentarily.

2. Derating design

Derating is essential in any reliable design and a significant factor in consideration of product life. Sufficient derating is needed against maximum rating when designing a system.

And also, relays should be examined using a measurement equipment.

Derated voltages must be considered according to operating and environmental conditions the relay will be subjected to.

3. Short across terminals

Do not short circuit between terminals when relay is energized, since there is possibility of breaking of the internal IC.

4. LED forward input current

Use with an LED forward input current increase and decrease rate, $\Delta I_F/\Delta t$, of at least 100 $\mu\text{A/s}$.

5. Ripple in the input power supply

If ripple is present in the input power supply, observe the following:

1) For LED operate current at E_{\min} , please maintain 2 mA.

2) Please make sure for E_{\max} is no higher the LED operate current at than 50 mA.

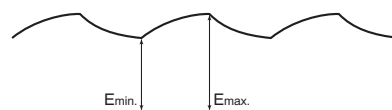

6. Output spike voltages

1) If an inductive load generates spike voltages which exceed the absolute maximum rating, the spike voltage must be limited. Typical circuits are shown below.

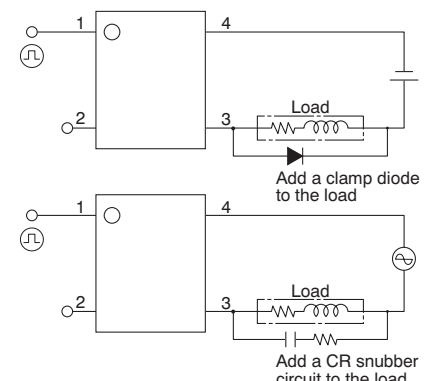

2) Even if spike voltages generated at the load are limited with a clamp diode or snubber circuit if the circuit wires are long, spike voltages will occur by inductance. Keep wires as short as possible to minimize inductance.

HS SOP 1 Form A

7. Cleaning

We recommend cleaning with an organic solvent. If you cannot avoid using ultrasonic cleansing, please ensure that the following conditions are met, and check beforehand for defects.

- Frequency: 27 to 29 kHz
- Ultrasonic output: No greater than 0.25W/cm²
- Cleaning time: No longer than 30 s
- Cleanser used: Asahiklin AK-225
- Other:

Submerge in solvent in order to prevent the PC board and elements from being contacted directly by the ultrasonic vibrations.

Note: Applies to unit area ultrasonic output for ultrasonic baths.

8. Notes for mounting

- 1) If many different packages are combined on a single substrate, then lead temperature rise is highly dependent on package size. For this reason, please make sure that the temperature of the terminal solder area of the PhotoMOS relay falls within the temperature conditions of item 10 before mounting.
- 2) If the mounting conditions exceed the recommended solder conditions in item 10, resin strength will fall and the nonconformity of the heat expansion coefficient of each constituent material will increase markedly, possibly causing cracks in the package, severed bonding wires, and the like. For this reason, please inquire with us about whether this use is possible.

3) We recommend cleaning with an organic solvent.

If you cannot avoid using ultrasonic cleaning, check beforehand for defects.

9. Input wiring pattern

With AQY series avoid installing the input (LED side) wiring pattern to the bottom side of the package if you require the specified I/O isolation voltage (V_{iso}) after mounting the PC board. Since part of the frame on the output side is exposed, it may cause fluctuations in the I/O isolation voltage.

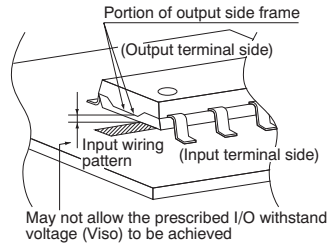

10. Soldering

Example of recommended soldering conditions

(1) IR (Infrared reflow) soldering method

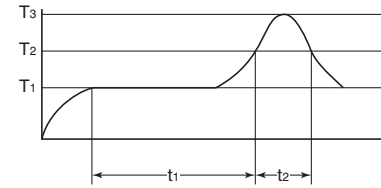

$T_1 = 150$ to 180°C 302 to 356°F
 $T_2 = 230^\circ\text{C}$ 446 $^\circ\text{F}$
 $T_3 = 245^\circ\text{C}$ 473 $^\circ\text{F}$ or less
 $t_1 = 60$ to 120 s or less
 $t_2 = 30$ s or less

(2) Soldering iron method

Tip temperature: 350 to 400°C 662 to 752°F

Wattage: 30 to 60 W

Soldering time: within 3 s

(3) Others

Check mounting conditions before using other soldering methods (DWS, VPS, hot-air, hot plate, laser, pulse heater, etc.)

- When using lead-free solder, we recommend a type with an alloy composition of Sn 3.0 Ag 0.5 Cu. Please inquire about soldering conditions and other details.
- The temperature profile indicates the temperature of the soldered terminal on the surface of the PC board. The ambient temperature may increase excessively. Check the temperature under mounting conditions.

11. Packing format

1) Tape and reel

mm inch

Tape dimensions

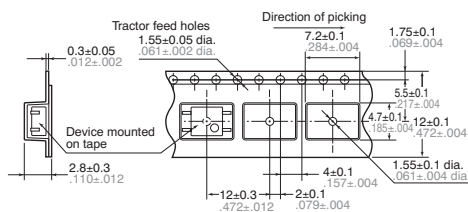

- (1) When picked from 1/2-pin side: Part No. AQY23○SX (Shown above)
- (2) When picked from 3/4-pin side: Part No. AQY23○SZ

Dimensions of paper tape reel

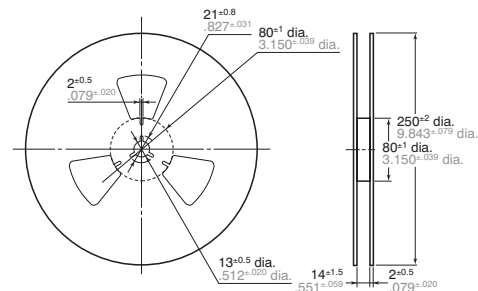

2) Tube

Devices are packaged in a tube so that pin No. 1 is on the stopper B side. Observe correct orientation when mounting them on PC boards.

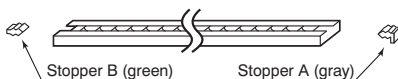

12. Transportation and storage

1) Extreme vibration during transport will warp the lead or damage the relay. Handle the outer and inner boxes with care.

2) Storage under extreme conditions will cause soldering degradation, external appearance defects, and deterioration of the characteristics. The following storage conditions are recommended:

- Temperature: 0 to 45°C 32 to 113°F
- Humidity: Less than 70% R.H.
- Atmosphere: No harmful gasses such as sulfurous acid gas, minimal dust.

3) Storage method for SOP type PhotoMOS relays implemented in SOP type are sensitive to moisture and come in sealed moisture-proof packages. Observe the following cautions on storage.

- After the moisture-proof package is unsealed, take the devices out of storage as soon as possible (within 1 month, less than 45°C 113°F/70% R.H.).
- If the devices are to be left in storage for a considerable period after the moisture-proof package has been unsealed, it is recommended to keep them in another moisture-proof bag containing silica gel (within 3 months at the most).

Panasonic

ideas for life



**Flat Power-DIP4-pin type
with high capacity
up to 2A load current**

**PhotoMOS[®]
PD 1 Form A
(AQY27○)**

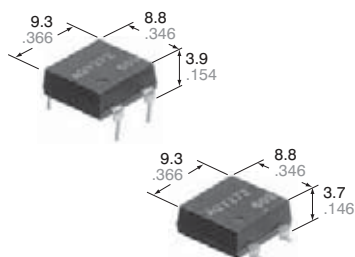

CAD Data

mm inch

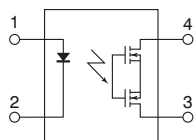

FEATURES

1. Flat-Packaged type

(W) 8.8 × (D) 9.3 × (H) 3.9 mm

(W) .346 × (D) .366 × (H) .154 inch

2. High capacity of continuous load current 2A (AQY272)

3. High sensitivity and low on-resistance

Max. 2A load can be controlled with 5mA input current. The on-resistance is low at typ. 0.11Ω (AQY272).

TYPICAL APPLICATIONS

- Measuring and Testing equipment
- IC Testers and Board Testers
- High speed inspection machines

TYPES

Type	Output rating*		Package	Part No.				Packing quantity	
	Load voltage	Load current		Through hole terminal	Surface-mount terminal		Tube	Tape and reel	
					Tape and reel packing style				
			Tube packing style		Picked from the 1/2-pin side	Picked from the 3/4-pin side			
AC/DC dual use	60V	2.0A	Power-DIP4-pin	AQY272	AQY272A	AQY272AX	AQY272AZ	1 tube contains: 50 pcs. 1 batch contains: 1,000 pcs.	1,000 pcs.
	100V	1.3A		AQY275	AQY275A	AQY275AX	AQY275AZ		
	200V	0.65A		AQY277	AQY277A	AQY277AX	AQY277AZ		
	400V	0.35A		AQY274	AQY274A	AQY274AX	AQY274AZ		

* Indicate the peak AC and DC values.

Note: The surface mount terminal indicator "A" and the packing style indicator "X" or "Z" are not marked on the relay.

RATING

1. Absolute maximum ratings (Ambient temperature: 25°C 77°F)

Item		Symbol	AQY272(A)	AQY275(A)	AQY277(A)	AQY274(A)	Remarks
Input	LED forward current	I _F	50 mA				
	LED reverse voltage	V _R	5 V				
	Peak forward current	I _{FP}	1 A				f = 100 Hz, Duty factor = 0.1%
	Power dissipation	P _{in}	75 mW				
Output	Load voltage (peak AC)	V _L	60 V	100 V	200 V	400 V	
	Continuous load current	I _L	2.0 A	1.3 A	0.65 A	0.35 A	Peak AC, DC
	Peak load current	I _{peak}	6.0 A	4.0 A	2.0 A	1.0 A	100ms (1 shot), V _L = DC
	Power dissipation	P _{out}	700 mW				
Total power dissipation		P _T	750 mW				
I/O isolation voltage		V _{iso}	2,500 V AC				
Temperature limits	Operating	T _{opr}	-40°C to +85°C -40°F to +185°F				Non-condensing at low temperatures
	Storage	T _{stg}	-40°C to +100°C -40°F to +212°F				

PD 1 Form A (AQY27○)

2. Electrical characteristics (Ambient temperature: 25°C 77°F)

Item		Symbol	AQY272(A)	AQY275(A)	AQY277(A)	AQY274(A)	Condition
Input	LED operate current	Typical	1.0 mA				$I_L = 100 \text{ mA}$ $V_L = 10 \text{ V}$
		Maximum	3.0 mA				
	LED turn off current	Minimum	0.4 mA				$I_L = 100 \text{ mA}$ $V_L = 10 \text{ V}$
		Typical	0.9 mA				
LED dropout voltage	Typical	1.25 V (1.16 V at $I_F = 10 \text{ mA}$)				$I_F = 50 \text{ mA}$	
	Maximum	1.5 V					
Output	On resistance	Typical	0.11 Ω	0.23 Ω	0.7 Ω	2.1 Ω	$I_F = 10 \text{ mA}$, $I_L = \text{Max.}$ Within 1 s on time
		Maximum	0.18 Ω	0.34 Ω	1.1 Ω	3.2 Ω	
	Off state leakage current	Maximum	10 μA				$I_F = 0 \text{ mA}$, $V_L = \text{Max.}$
Transfer characteristics	Turn on time*	Typical	2.46 ms	2.40 ms	1.12 ms	1.65 ms	$I_F = 10 \text{ mA}$, $I_L = 100 \text{ mA}$ $V_L = 10 \text{ V}$
		Maximum	5.0 ms				
		Typical	5.64 ms	5.65 ms	2.57 ms	3.88 ms	$I_F = 5 \text{ mA}$, $I_L = 100 \text{ mA}$ $V_L = 10 \text{ V}$
		Maximum	10.0 ms				
	Turn off time*	Typical	0.22 ms	0.21 ms	0.10 ms	0.08 ms	$I_F = 5 \text{ mA}$ or 10 mA , $I_L = 100 \text{ mA}$ $V_L = 10 \text{ V}$
		Maximum	3.0 ms				
	I/O capacitance	Typical	0.8 pF				$f = 1 \text{ MHz}$ $V_B = 0 \text{ V}$
		Maximum	1.5 pF				
Initial I/O isolation resistance	Minimum	1,000 M Ω				500 V DC	
Maximum operating speed	Maximum	—				$I_F = 10 \text{ mA}$, Duty factor = 50% $I_L = \text{Max.}$, $V_L = \text{Max.}$	

*Turn on/Turn off time

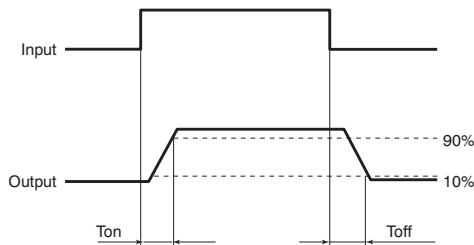

RECOMMENDED OPERATING CONDITIONS

Please obey the following conditions to ensure proper relay operation and resetting.

Item	Symbol	Recommended value	Unit
Input LED current	I_F	5 to 10	mA

■ For Dimensions, see page 63.

■ For Schematic and Wiring Diagrams, see page 64.

■ For Cautions for Use, see page 71.

■ These products are not designed for automotive use.

If you are considering to use these products for automotive applications, please contact your local Panasonic technical representative.

For more information, see page 80.

REFERENCE DATA

1. Load current vs. ambient temperature characteristics

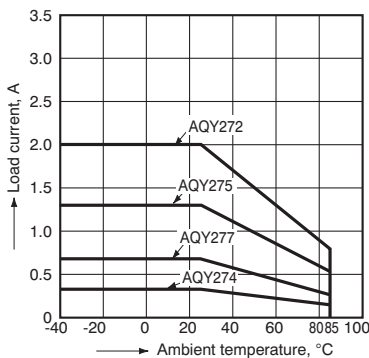
Allowable ambient temperature: -40°C to $+85^\circ\text{C}$
 -40°F to $+185^\circ\text{F}$ 

2-(1) On resistance vs. ambient temperature characteristics

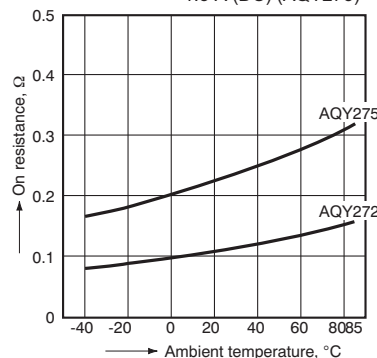
LED current: 10 mA;
Continuous load current: 2.0 A (DC) (AQY272),
1.3 A (DC) (AQY275)

2-(2) On resistance vs. ambient temperature characteristics

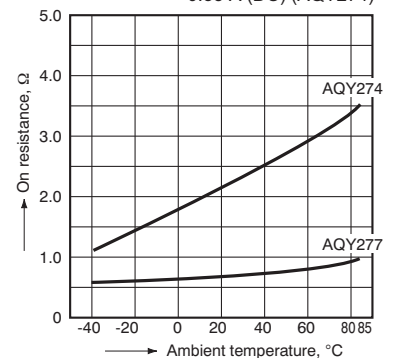
LED current: 10 mA;
Continuous load current: 0.65 A (DC) (AQY277),
0.35 A (DC) (AQY274)

PD 1 Form A (AQY27○)

3. Turn on time vs. ambient temperature characteristics

LED current: 10 mA; Load voltage: 10 V (DC);
Continuous load current: 100 mA (DC)

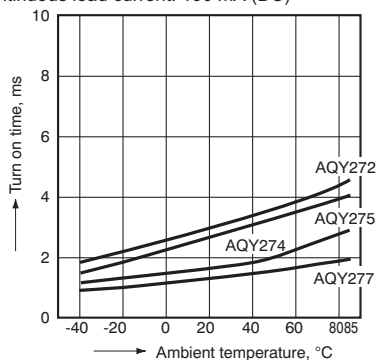

4. Turn off time vs. ambient temperature characteristics

LED current: 10 mA; Load voltage: 10 V (DC);
Continuous load current: 100 mA (DC)

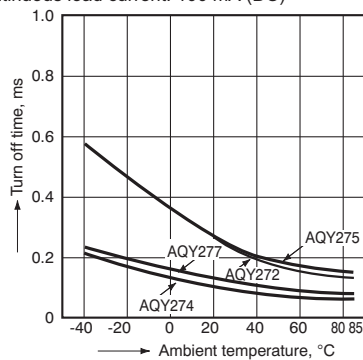

5. LED operate vs. ambient temperature characteristics

Load voltage: 10 V (DC);
Continuous load current: 100 mA (DC)

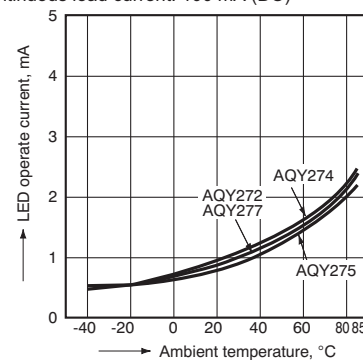

6. LED turn off current vs. ambient temperature characteristics

Load voltage: 10 V (DC);
Continuous load current: 100 mA (DC)

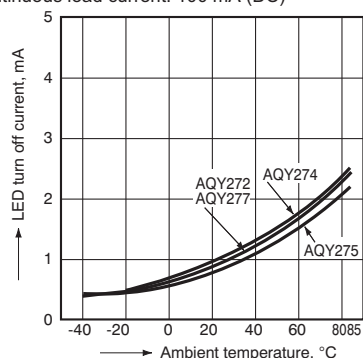

7. LED dropout voltage vs. ambient temperature characteristics

Sample: all types;
LED current: 5 to 50 mA

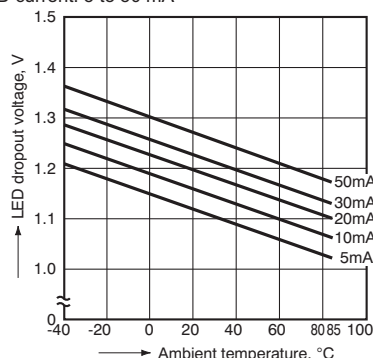

8. Current vs. voltage characteristics of output at MOS portion

Ambient temperature: 25°C 77°F

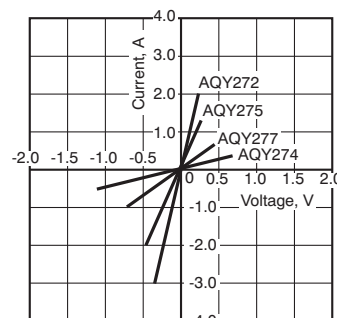

9-(1) Off state leakage current vs. load voltage characteristics

Ambient temperature: 25°C 77°F

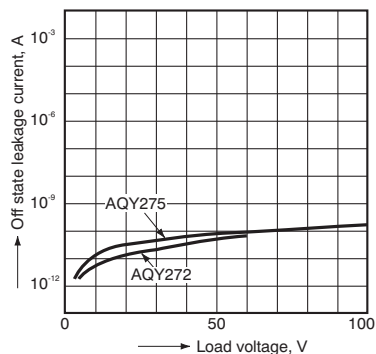

9-(2) Off state leakage current vs. load voltage characteristics

Ambient temperature: 25°C 77°F

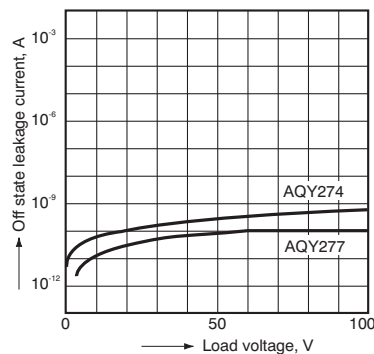

10. Turn on time vs. LED forward current characteristics

Load voltage: 10 V (DC); Continuous load current:
100 mA (DC); Ambient temperature: 25°C 77°F

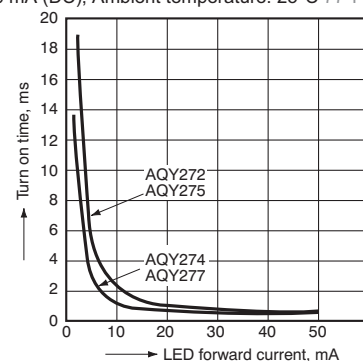

11. Turn off time vs. LED forward current characteristics

Load voltage: 10 V (DC); Continuous load current:
100 mA (DC); Ambient temperature: 25°C 77°F

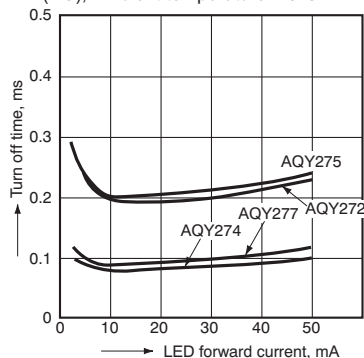

12-(1) Turn on time vs. load voltage characteristics

LED current: 10 mA; Continuous load current:
100 mA; Ambient temperature: 25°C 77°F

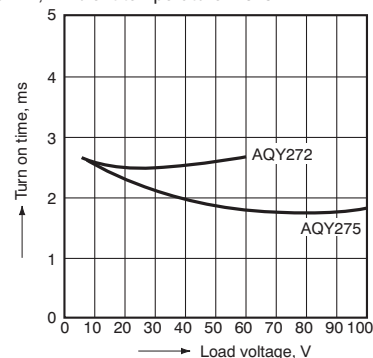

12-(2) Turn on time vs. load voltage characteristics

LED current: 10 mA; Continuous load current:
100 mA; Ambient temperature: 25°C 77°F

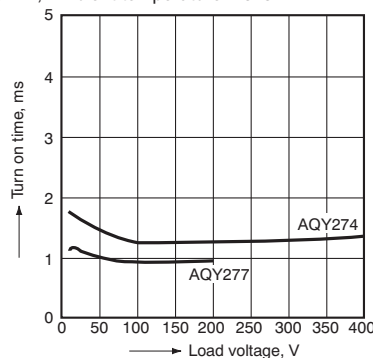

PD 1 Form A (AQY27○)

PhotoMOS

13-(1) Turn on time vs. load current characteristics

LED current: 10 mA; Load voltage: 10 V (DC); Ambient temperature: 25°C 77°F

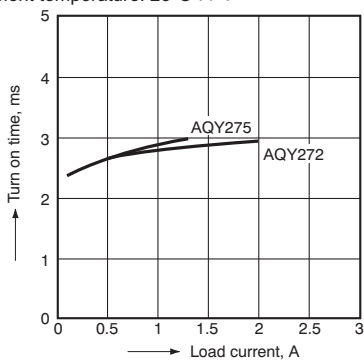

13-(2) Turn on time vs. load current characteristics

LED current: 10 mA; Load voltage: 10 V (DC); Ambient temperature: 25°C 77°F

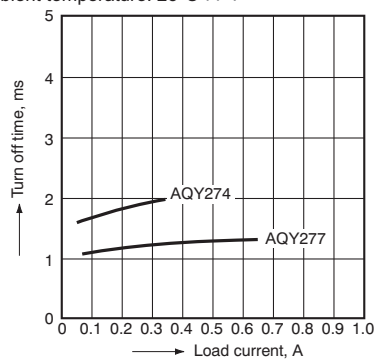

14-(1) Turn off time vs. load voltage characteristics

LED current: 10 mA; Continuous load current: 100 mA; Ambient temperature: 25°C 77°F

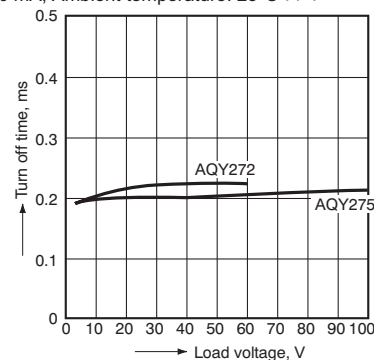

14-(2) Turn off time vs. load voltage characteristics

LED current: 10 mA; Continuous load current: 100 mA; Ambient temperature: 25°C 77°F

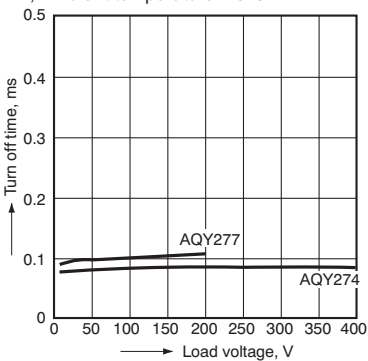

15-(1) Turn off time vs. load current characteristics

LED current: 10 mA; Load voltage 10 V (DC); Ambient temperature: 25°C 77°F

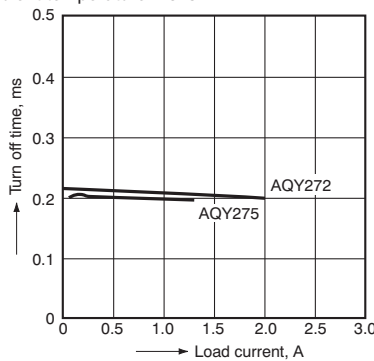

15-(2) Turn off time vs. load current characteristics

LED current: 10 mA; Load voltage 10 V (DC); Ambient temperature: 25°C 77°F

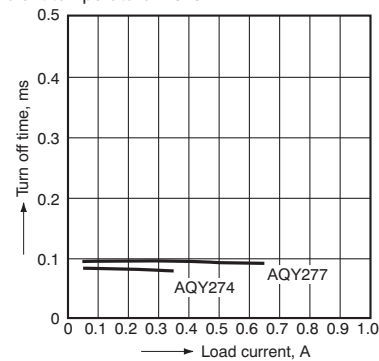

16. Maximum operating frequency vs. load voltage/current characteristics

LED current: 10 mA; Ambient temperature: 25°C 77°F

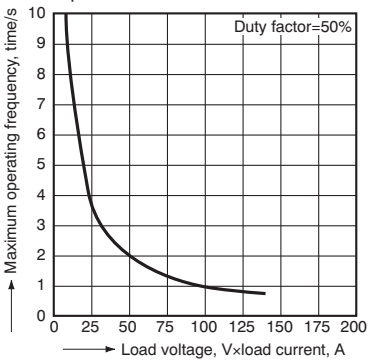

17. Output capacitance vs. applied voltage characteristics

Frequency: 1 MHz; Ambient temperature: 25°C 77°F

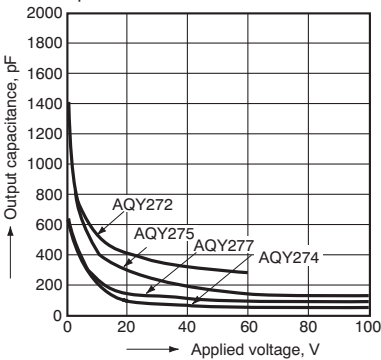

Panasonic

ideas for life



**Slim type with
high capacity up to 4A
DC load type also available**

**PhotoMOS®
Power 1 Form A
(AQZ100, 200)**

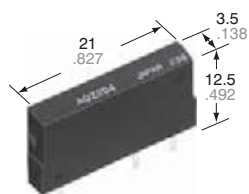

(Height includes standoff)

CAD Data

mm inch

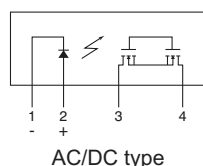
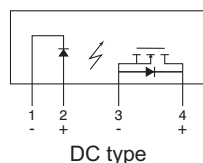

FEATURES

- 1. Slim SIL4-pin package**
(W) 3.5 × (D) 21.0 × (H) 12.5 mm
(W) .138 × (D) .827 × (H) .492 inch
The compact size of the 4-pin SIL package allows high density mounting.
- 2. Extremely low on-resistance**
- 3. Control low-level signal**
Power Photo MOS relays feature extremely low closed-circuit offset voltage to enable control of low-level analog signals without distortion.
- 4. Low-level off state leakage current of max. 10 μA**
- 5. High I/O isolation voltage of 2,500 V**
- 6. Eliminates the need for a counter electromotive protection diode in the drive circuit on the input side**
- 7. Eliminates the need for a power supply to drive the power MOSFET**
- 8. No restriction on mounting direction**
- 9. Low thermoelectromotive force**
- 10. Neither noise nor arc at contact**
- 11. Sockets are also available**
(PA1a-PS, PA1a-PS-H)
- 12. Can be installed on the RT-3 relay terminal (Power PhotoMOS relay type)**

TYPICAL APPLICATIONS

- Traffic signals
- Measuring instruments
- Industrial machines

TYPES

1. DC type

	Output rating*		Package	Part No.	Packing quantity	
	Load voltage	Load current			Inner carton	Outer carton
DC only	60 V	4.0 A	SIL4-pin	AQZ102	25 pcs.	500 pcs.
	100 V	2.6 A		AQZ105		
	200 V	1.3 A		AQZ107		
	400 V	0.7 A		AQZ104		

* Load voltage and current of DC type: DC

2. AC/DC type

	Output rating*		Package	Part No.	Packing quantity	
	Load voltage	Load current			Inner carton	Outer carton
AC/DC dual use	60 V	3.0 A	SIL4-pin	AQZ202	25 pcs.	500 pcs.
	100 V	2.0 A		AQZ205		
	200 V	1.0 A		AQZ207		
	400 V	0.5 A		AQZ204		

* Load voltage and current of AC/DC type: Peak AC/DC.

Power 1 Form A (AQZ10○, 20○)

RATING

1. DC type

1) Absolute maximum ratings (Ambient temperature: 25°C 77°F)

Item		Symbol	AQZ102	AQZ105	AQZ107	AQZ104	Remarks
Input	LED forward current	I_F	50 mA				
	LED reverse voltage	V_R	5 V				
	Peak forward current	I_{FP}	1 A				f = 100 Hz, Duty factor = 0.1%
	Power dissipation	P_{in}	75 mW				
Output	Load voltage (DC)	V_L	60 V	100 V	200 V	400 V	
	Continuous load current (DC)	I_L	4.0 A	2.6 A	1.3 A	0.7 A	
	Peak load current	I_{peak}	9.0 A	6.0 A	3.0 A	1.5 A	100 ms (1 shot), $V_L = DC$
	Power dissipation	P_{out}	1.35 W				
Total power dissipation		P_T	1.35 W				
I/O isolation voltage		V_{iso}	2,500 V AC				
Temperature limits	Operating	T_{opr}	-40°C to +85°C -40°F to +185°F				Non-condensing at low temperatures
	Storage	T_{stg}	-40°C to +100°C -40°F to +212°F				

2) Electrical characteristics (Ambient temperature: 25°C 77°F)

Item			Symbol	AQZ102	AQZ105	AQZ107	AQZ104	Condition
Input	LED operate current	Typical	I_{Fon}	1.0 mA				$I_L = 100 \text{ mA}$ $V_L = 10 \text{ V}$
		Maximum		3.0 mA				
	LED turn off current	Minimum	I_{Foff}	0.4 mA				$I_L = 100 \text{ mA}$ $V_L = 10 \text{ V}$
		Typical		0.9 mA				
LED dropout voltage	Typical	V_F	1.25 V (1.16 V at $I_F = 10 \text{ mA}$)				$I_F = 50 \text{ mA}$	
	Maximum		1.5 V					
Output	On resistance	Typical	R_{on}	0.05 Ω	0.081 Ω	0.34 Ω	1.06 Ω	$I_F = 10 \text{ mA}$ $I_L = \text{Max.}$ Within 1 s on time
		Maximum		0.09 Ω	0.17 Ω	0.55 Ω	1.6 Ω	
	Off state leakage current	Maximum	I_{Leak}	10 μA				$I_F = 0 \text{ mA}$ $V_L = \text{Max.}$
Transfer characteristics	Turn on time*	Typical	T_{on}	1.66 ms	1.89 ms	0.83 ms	1.01 ms	$I_F = 10 \text{ mA}$ $I_L = 100 \text{ mA}$ $V_L = 10 \text{ V}$
		Maximum		5.0 ms				
		Typical		3.79 ms	4.50 ms	1.75 ms	2.34 ms	
		Maximum		10.0 ms				
	Turn off time*	Typical	T_{off}	0.15 ms	0.19 ms	0.08 ms	0.08 ms	$I_F = 5 \text{ mA or } 10 \text{ mA}$ $I_L = 100 \text{ mA}$ $V_L = 10 \text{ V}$
		Maximum		3.0 ms				
	I/O capacitance	Typical	C_{iso}	0.8 pF				f = 1 MHz $V_B = 0 \text{ V}$
		Maximum		1.5 pF				
Initial I/O isolation resistance	Minimum	R_{iso}	1,000 M Ω				500 V DC	
Maximum operating speed	Maximum	—	0.5 cps				$I_F = 10 \text{ mA}$ Duty factor = 50% $I_L \times V_L = 200 \text{ (VA)}$	
Vibration resistance	Minimum	—	10 to 55 Hz at double amplitude of 3 mm				2 hours for 3 axes	
Shock resistance	Minimum	—	4,900 m/s ² (500 G) 1 ms				3 times for 3 axes	

Power 1 Form A (AQZ10○, 20○)

2. AC/DC type

1) Absolute maximum ratings (Ambient temperature: 25°C 77°F)

Item		Symbol	AQZ202	AQZ205	AQZ207	AQZ204	Remarks
Input	LED forward current	I_F	50 mA				
	LED reverse voltage	V_R	5 V				
	Peak forward current	I_{FP}	1 A				$f = 100 \text{ Hz}$, Duty factor = 0.1%
	Power dissipation	P_{in}	75 mW				
Output	Load voltage (Peak AC)	V_L	60 V	100 V	200 V	400 V	
	Continuous load current	I_L	3.0 A	2.0 A	1.0 A	0.5 A	Peak AC, DC
	Peak load current	I_{peak}	9.0 A	6.0 A	3.0 A	1.5 A	100 ms (1 shot), $V_L = \text{DC}$
	Power dissipation	P_{out}	1.6 W				
Total power dissipation		P_T	1.6 W				
I/O isolation voltage		V_{iso}	2,500 V AC				
Temperature limits	Operating	T_{opr}	-40°C to +85°C -40°F to +185°F				Non-condensing at low temperatures
	Storage	T_{stg}	-40°C to +100°C -40°F to +212°F				

2) Electrical characteristics (Ambient temperature: 25°C 77°F)

Item		Symbol	AQZ202	AQZ205	AQZ207	AQZ204	Condition
Input	LED operate current	Typical	1.0 mA				$I_L = 100 \text{ mA}$ $V_L = 10 \text{ V}$
		Maximum	3.0 mA				
	LED turn off current	Minimum	0.4 mA				$I_L = 100 \text{ mA}$ $V_L = 10 \text{ V}$
		Typical	0.9 mA				
LED dropout voltage	Typical	1.25 V (1.16 V at $I_F = 10 \text{ mA}$)				$I_F = 50 \text{ mA}$	
	Maximum	1.5 V					
Output	On resistance	Typical	0.11 Ω	0.23 Ω	0.7 Ω	2.1 Ω	$I_F = 10 \text{ mA}$ $I_L = \text{Max.}$ Within 1 s on time
		Maximum	0.18 Ω	0.34 Ω	1.1 Ω	3.2 Ω	
	Off state leakage current	Maximum	10 μA				$I_F = 0 \text{ mA}$ $V_L = \text{Max.}$
Transfer characteristics	Turn on time*	Typical	2.46 ms	2.40 ms	1.12 ms	1.65 ms	$I_F = 10 \text{ mA}$ $I_L = 100 \text{ mA}$ $V_L = 10 \text{ V}$
		Maximum	5.0 ms				
		Typical	5.64 ms	5.65 ms	2.57 ms	3.88 ms	
		Maximum	10.0 ms				
	Turn off time*	Typical	0.22 ms	0.21 ms	0.10 ms	0.08 ms	$I_F = 5 \text{ mA}$ or 10 mA $I_L = 100 \text{ mA}$ $V_L = 10 \text{ V}$
		Maximum	3.0 ms				
	I/O capacitance	Typical	0.8 pF				$f = 1 \text{ MHz}$ $V_B = 0 \text{ V}$
		Maximum	1.5 pF				
Initial I/O isolation resistance	Minimum	1,000 M Ω				500 V DC	
Maximum operating speed	Maximum	0.5 cps				$I_F = 10 \text{ mA}$ Duty factor = 50% $I_L = \text{Max.}$, $V_L = \text{Max.}$	
Vibration resistance	Minimum	10 to 55 Hz at double amplitude of 3 mm				2 hours for 3 axes	
Shock resistance	Minimum	4,900 m/s ² {500 G} 1 ms				3 times for 3 axes	

*Turn on/off time

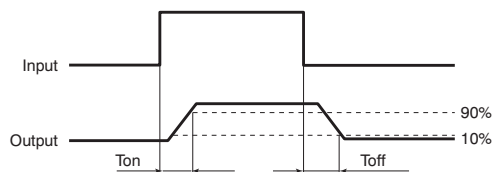

RECOMMENDED OPERATING CONDITIONS

Please obey the following conditions to ensure proper relay operation and resetting.

Item	Symbol	Recommended value	Unit
Input LED current	I_F	5 to 10	mA

■ For Dimensions, see page 63.

■ For Schematic and Wiring Diagrams, see page 67.

■ For Cautions for Use, see page 71.

■ These products are not designed for automotive use.

If you are considering to use these products for automotive applications, please contact your local Panasonic technical representative.

For more information, see page 80.

Power 1 Form A (AQZ10○, 20○)

REFERENCE DATA

18-(1) Load current vs. ambient temperature characteristics (DC type)

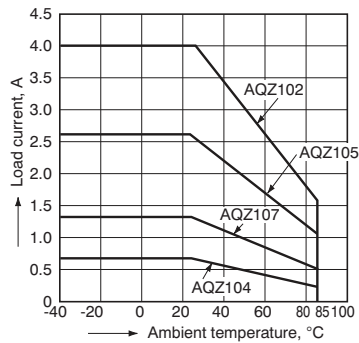
Allowable ambient temperature: -40°C to +85°C
-40°F to +185°F

1.-(2) Load current vs. ambient temperature characteristics (AC/DC type)

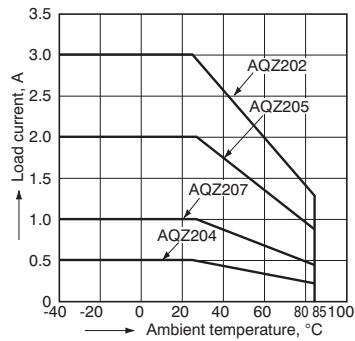
Allowable ambient temperature: -40°C to +85°C
-40°F to +185°F

19. Load current vs. ambient temperature characteristics in adjacent mounting

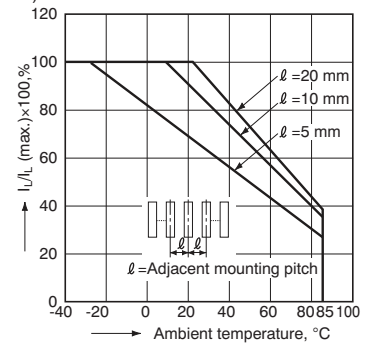
I_L: Load current;
I_L(max.): Maximum continuous load current

20-(1) On resistance vs. ambient temperature characteristics (DC type)

LED current: 10 mA;

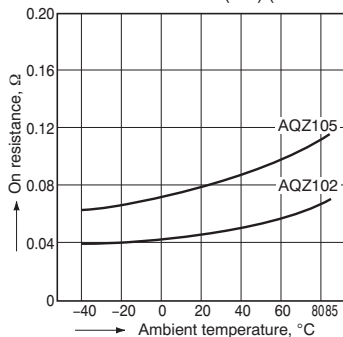
Continuous load current: 1.6 A (DC) (AQZ102),
1.04 A (DC) (AQZ105)

3.-(2) On resistance vs. ambient temperature characteristics (DC type)

LED current: 10 mA;

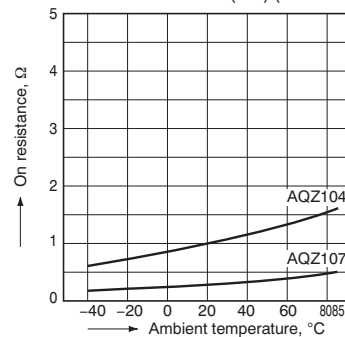
Continuous load current: 0.52 A (DC) (AQZ107),
0.28 A (DC) (AQZ104)

3.-(3) On resistance vs. ambient temperature characteristics (AC/DC type)

LED current: 10 mA;

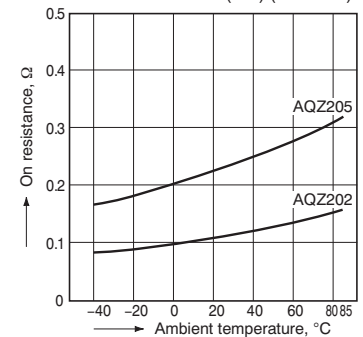
Continuous load current: 1.2 A (DC) (AQZ202),
0.8 A (DC) (AQZ205)

3.-(4) On resistance vs. ambient temperature characteristics (AC/DC type)

LED current: 10 mA;

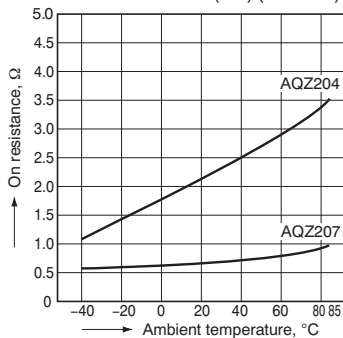
Continuous load current: 0.4 A (DC) (AQZ207),
0.2 A (DC) (AQZ204)

21-(1) Turn on time vs. ambient temperature characteristics (DC type)

LED current: 10 mA;

Load voltage: 10 V (DC);

Continuous load current: 100 mA (DC)

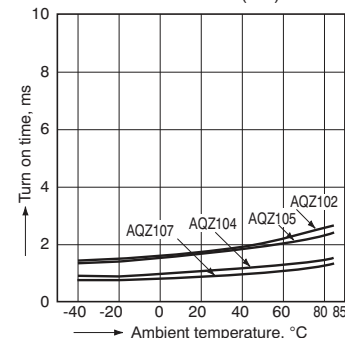

4.-(2) Turn on time vs. ambient temperature characteristics (AC/DC type)

LED current: 10 mA;

Load voltage: 10 V (DC);

Continuous load current: 100 mA (DC)

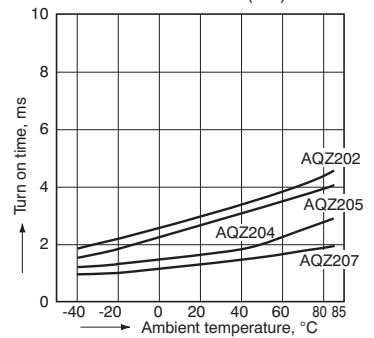

22-(1) Turn off time vs. ambient temperature characteristics (DC type)

LED current: 10 mA;

Load voltage: 10 V (DC);

Continuous load current: 100 mA (DC)

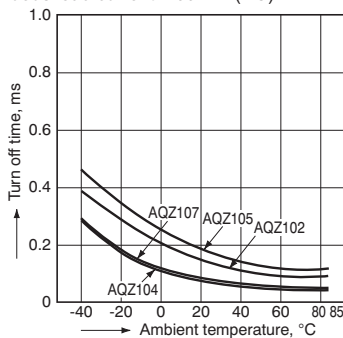

5.-(2) Turn off time vs. ambient temperature characteristics (AC/DC type)

LED current: 10 mA;

Load voltage: 10 V (DC);

Continuous load current: 100 mA (DC)

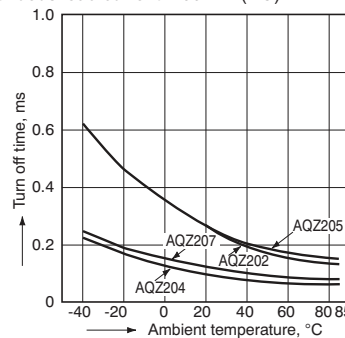

23-(1) LED operate vs. ambient temperature characteristics (DC type)

Load voltage: 10 V (DC);

Continuous load current: 100 mA (DC)

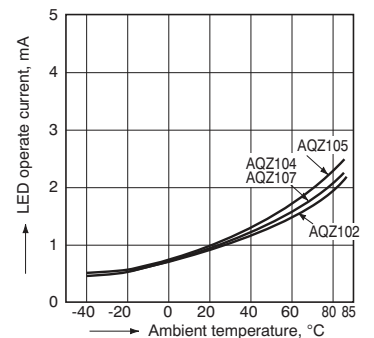

Power 1 Form A (AQZ100, 200)

6.-(2) LED operate vs. ambient temperature characteristics (AC/DC type)

Load voltage: 10 V (DC);
Continuous load current: 100 mA (DC)

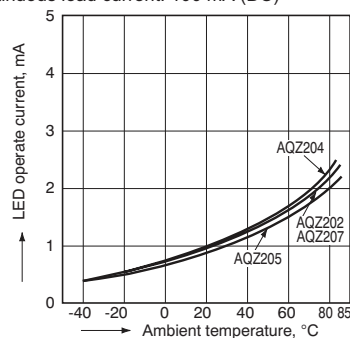

24.-(1) LED turn off current vs. ambient temperature characteristics (DC type)

Load voltage: 10 V (DC);
Continuous load current: 100 mA (DC)

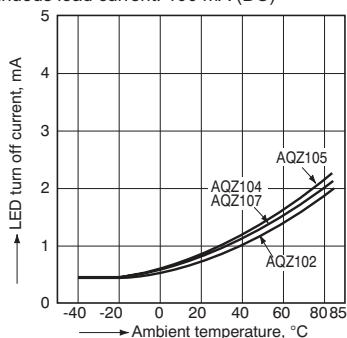

7.-(2) LED turn off current vs. ambient temperature characteristics (AC/DC type)

Load voltage: 10 V (DC);
Continuous load current: 100 mA (DC)

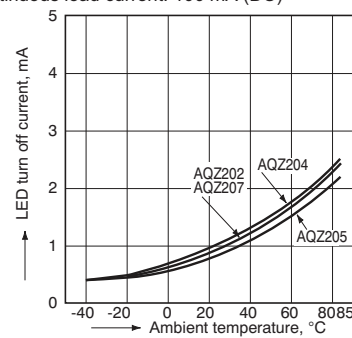

25. LED dropout voltage vs. ambient temperature characteristics

Sample: all types; LED current: 5 to 50 mA

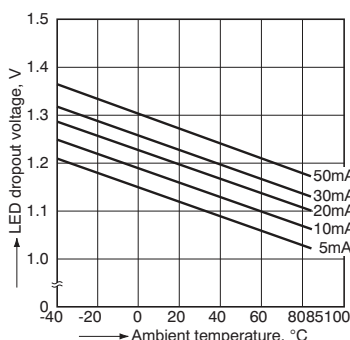

26.-(1) Current vs. voltage characteristics of output at MOS portion (DC type)

Ambient temperature: 25°C 77°F

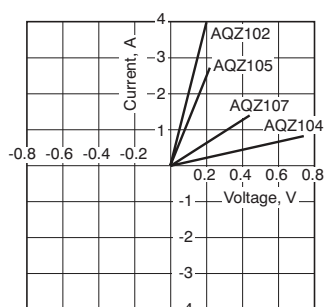

9.-(2) Current vs. voltage characteristics of output at MOS portion (AC/DC type)

Ambient temperature: 25°C 77°F

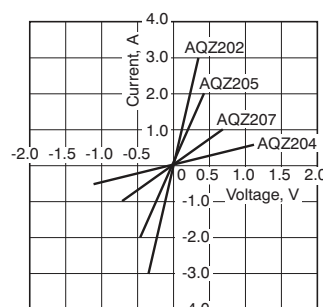

27.-(1) Off state leakage current vs. load voltage characteristics

Ambient temperature: 25°C 77°F

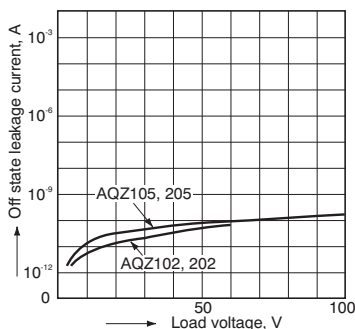

10.-(2) Off state leakage current vs. load voltage characteristics

Ambient temperature: 25°C 77°F

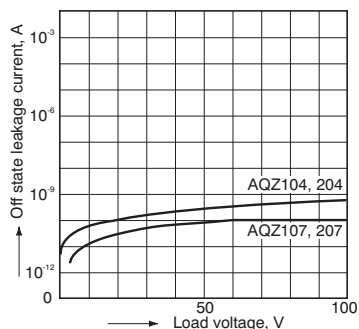

28.-(1) Turn on time vs. LED forward current characteristics (DC type)

Load voltage: 10 V (DC);
Continuous load current: 100 mA (DC);
Ambient temperature: 25°C 77°F

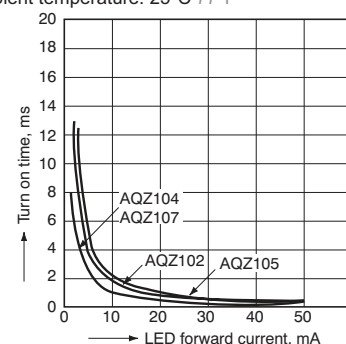

11.-(2) Turn on time vs. LED forward current characteristics (AC/DC type)

Load voltage: 10 V (DC);
Continuous load current: 100 mA (DC);
Ambient temperature: 25°C 77°F

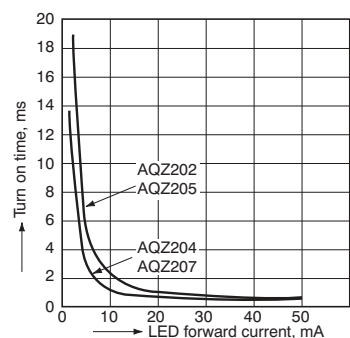

29.-(1) Turn off time vs. LED forward current characteristics (DC type)

Measured portion: between terminals 4 and 6;
Load voltage: 10 V (DC);
Continuous load current: 100 mA (DC);
Ambient temperature: 25°C 77°F

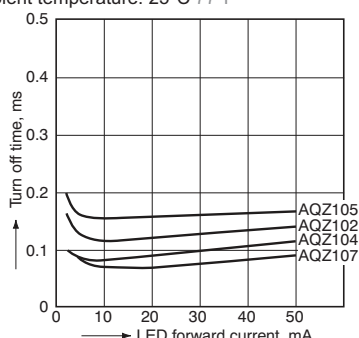

12.-(2) Turn off time vs. LED forward current characteristics (AC/DC type)

Load voltage: 10 V (DC);
Continuous load current: 100 mA (DC);
Ambient temperature: 25°C 77°F

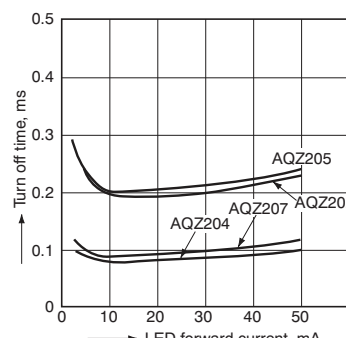

Power 1 Form A (AQZ10○, 20○)

30-(1) Turn on time vs. load voltage characteristics (DC type)

LED current: 10 mA;
Continuous load current: 100 mA;
Ambient temperature: 25°C 77°F

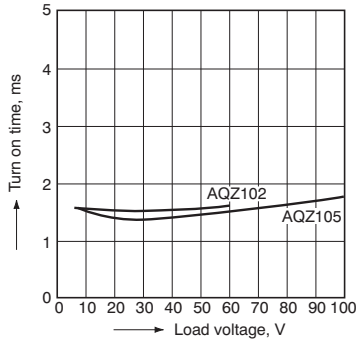

13.-(2) Turn on time vs. load voltage characteristics (DC type)

LED current: 10 mA;
Continuous load current: 100 mA;
Ambient temperature: 25°C 77°F

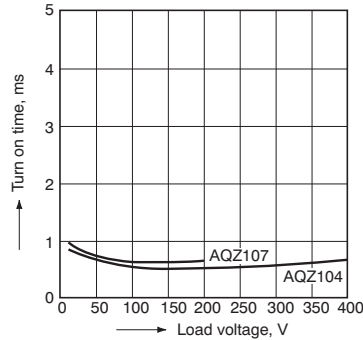

13.-(3) Turn on time vs. load voltage characteristics (AC/DC type)

LED current: 10 mA;
Continuous load current: 100 mA;
Ambient temperature: 25°C 77°F

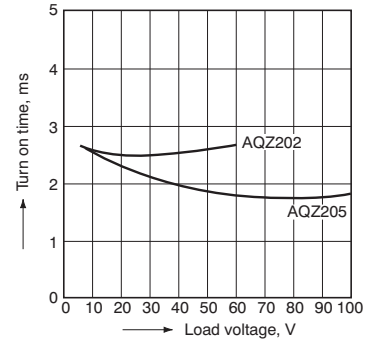

13.-(4) Turn on time vs. load voltage characteristics (AC/DC type)

LED current: 10 mA;
Continuous load current: 100 mA;
Ambient temperature: 25°C 77°F

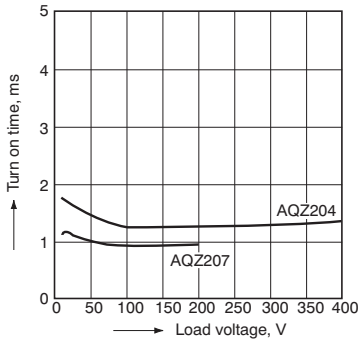

31-(1) Turn on time vs. load current characteristics (DC type)

LED current: 10 mA;
Load voltage: 10 V (DC);
Ambient temperature: 25°C 77°F

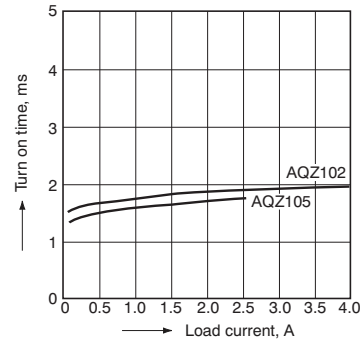

14.-(2) Turn on time vs. load current characteristics (DC type)

LED current: 10 mA;
Load voltage: 10 V (DC);
Ambient temperature: 25°C 77°F

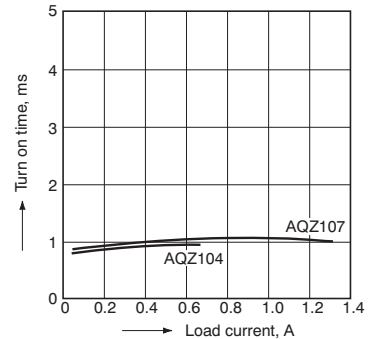

14.-(3) Turn on time vs. load current characteristics (AC/DC type)

LED current: 10 mA;
Load voltage: 10 V (DC);
Ambient temperature: 25°C 77°F

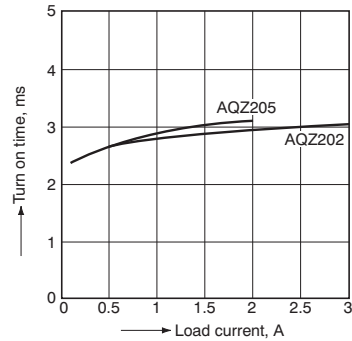

14.-(4) Turn on time vs. load current characteristics (AC/DC type)

LED current: 10 mA;
Load voltage: 10 V (DC);
Ambient temperature: 25°C 77°F

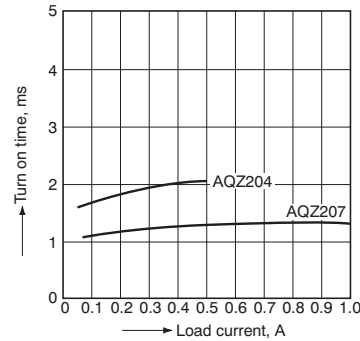

32-(1) Turn off time vs. load voltage characteristics (DC type)

LED current: 10 mA;
Continuous load current: 100 mA;
Ambient temperature: 25°C 77°F

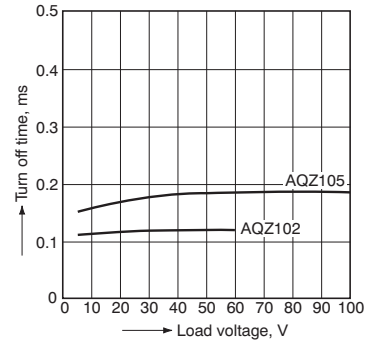

15.-(2) Turn off time vs. load voltage characteristics (DC type)

LED current: 10 mA;
Continuous load current: 100 mA;
Ambient temperature: 25°C 77°F

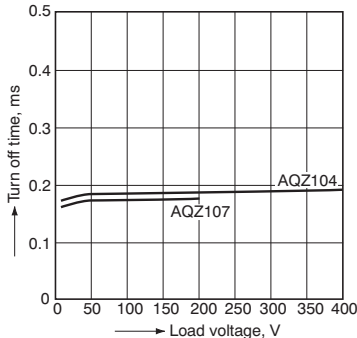

15.-(3) Turn off time vs. load voltage characteristics (AC/DC type)

LED current: 10 mA;
Continuous load current: 100 mA;
Ambient temperature: 25°C 77°F

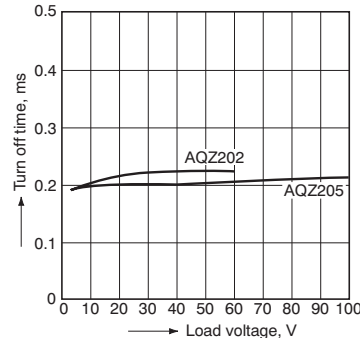

15.-(4) Turn off time vs. load voltage characteristics (AC/DC type)

LED current: 10 mA;
Continuous load current: 100 mA;
Ambient temperature: 25°C 77°F

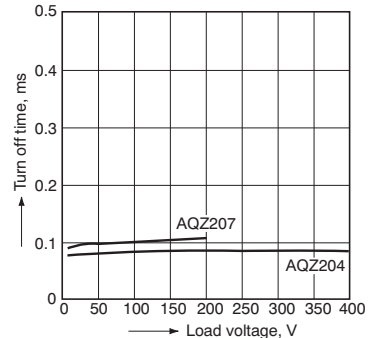

Power 1 Form A (AQZ100, 200)

33-(1) Turn off time vs. load current characteristics (DC type)

LED current: 10 mA;
Load voltage: 10 V (DC);
Ambient temperature: 25°C 77°F

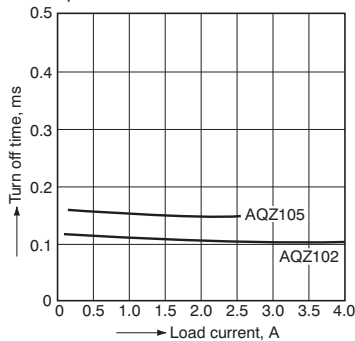

16.-(2) Turn off time vs. load current characteristics (DC type)

LED current: 10 mA;
Load voltage: 10 V (DC);
Ambient temperature: 25°C 77°F

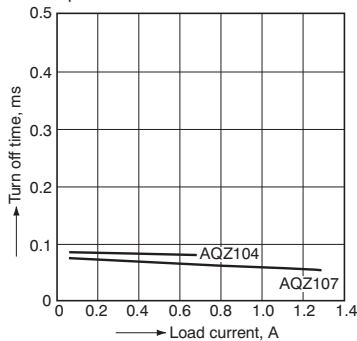

16.-(3) Turn off time vs. load current characteristics (AC/DC type)

LED current: 10 mA;
Load voltage: 10 V (DC);
Ambient temperature: 25°C 77°F

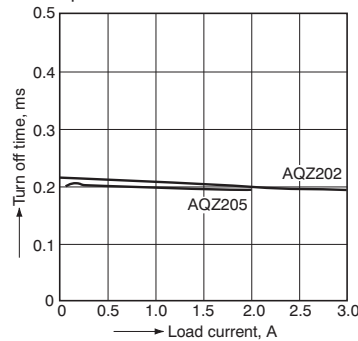

16.-(4) Turn off time vs. load current characteristics (AC/DC type)

LED current: 10 mA;
Load voltage: 10 V (DC);
Ambient temperature: 25°C 77°F

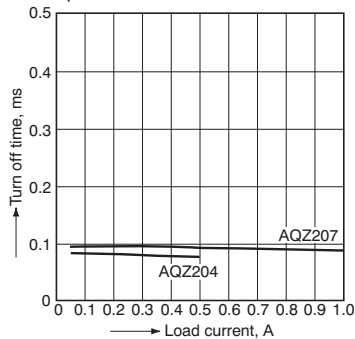

34. Maximum operating frequency vs. load voltage/current characteristics

LED current: 10 mA;
Ambient temperature: 25°C 77°F

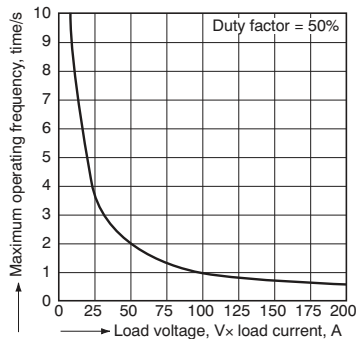

35-(1) Output capacitance vs. applied voltage characteristics (DC type)

Frequency: 1 MHz;
Ambient temperature: 25°C 77°F

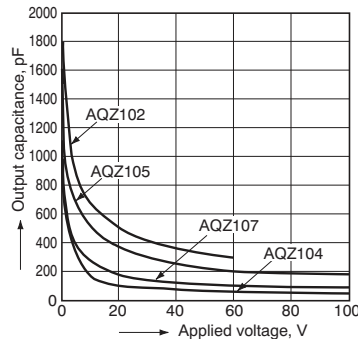

18.-(2) Output capacitance vs. applied voltage characteristics (AC/DC type)

Frequency: 1 MHz;
Ambient temperature: 25°C 77°F

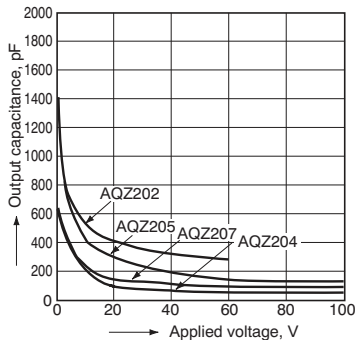

ACCESSORY (mm inch)

Socket

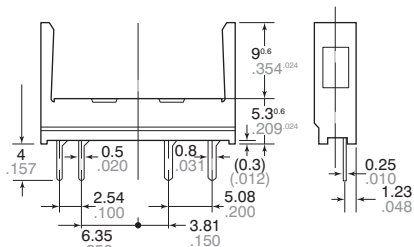
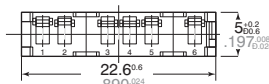
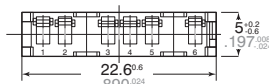

PA1a-PS

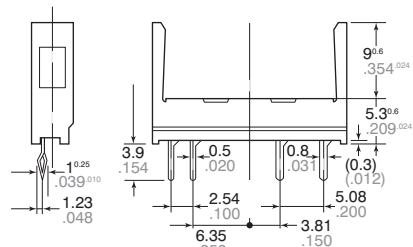

PA1a-PS-H

PC board pattern (BOTTOM VIEW) Standard type

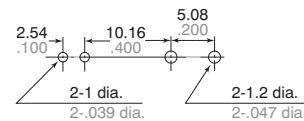

Self clincing type



Tolerance: $\pm 0.1 \pm 0.04$

Panasonic

ideas for life



Normally closed type
in a slim SIL package
Load voltage 400V

PhotoMOS[®]
Power 1 Form B
(AQZ404)

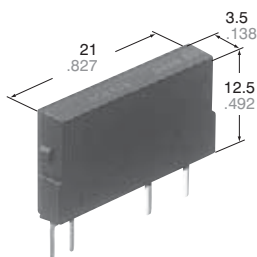

CAD Data

mm inch

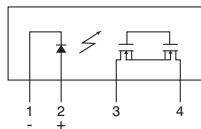

FEATURES

1. High sensitivity and low on-resistance

Max. 0.5A load can be controlled with 5 mA input current. The on-resistance is low at typ. 2.8Ω.

2. Normally closed (1 Form B) contact

This has been realized thanks to the built-in MOSFET processed by our proprietary method, DSD (Double-diffused and Selective Doping) method.

3. Slim SIL4-pin package

(W) 3.5 × (D) 21.0 × (H) 12.5 mm
(W) .138 × (D) .827 × (H) .492 inch

The compact size of the 4-pin SIL package allows high density mounting.

4. Sockets are also available

(PA1a-PS, PA1a-PS-H)

5. Can be installed on the RT-3 relay terminal (Power PhotoMOS relay type)

Cross section of the normally-closed type of power MOS

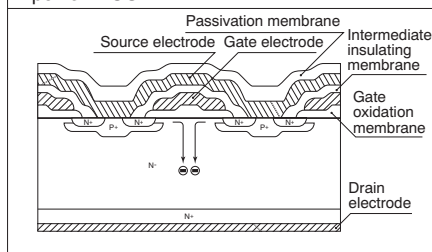

TYPICAL APPLICATIONS

- Railroad system, traffic signals
- Measuring instruments
- Industrial machines

TYPES

	Output rating*		Package	Part No.	Packing quantity	
	Load voltage	Load current			Inner carton	Outer carton
AC/DC dual use	400 V	0.5 A	SIL4-pin	AQZ404	25 pcs	500 pcs

*Indicate the peak AC and DC values.

RATING

1. Absolute maximum ratings (Ambient temperature: 25°C 77°F)

Item		Symbol	AQZ404	Remarks
Input	LED forward current	I _F	50 mA	
	LED reverse voltage	V _R	5 V	
	Peak forward current	I _{FP}	1 A	f = 100 Hz, Duty factor = 0.1%
	Power dissipation	P _{in}	75 mW	
Output	Load voltage (peak AC)	V _L	400 V	
	Continuous load current	I _L	0.5 A	Peak AC, DC
	Peak load current	I _{peak}	1.5 A	100 ms (1 shot), V _L = DC
	Power dissipation	P _{out}	1.6 W	
Total power dissipation		P _T	1.6 W	
I/O isolation voltage		V _{iso}	2,500 V AC	
Temperature limits	Operating	T _{opr}	-40°C to +85°C -40°F to +185°F	Non-condensing at low temperatures
	Storage	T _{stg}	-40°C to +100°C -40°F to +212°F	

Power 1 Form B (AQZ404)

2. Electrical characteristics (Ambient temperature: 25°C 77°F)

Item		Symbol	AQZ404	Condition
Input	LED operate (OFF) current	Typical	1.0 mA	$I_L = 100 \text{ mA}$ $V_L = 10 \text{ V}$
		Maximum	3.0 mA	
	LED reverse (ON) current	Minimum	0.4 mA	$I_L = 100 \text{ mA}$ $V_L = 10 \text{ V}$
		Typical	0.9 mA	
LED dropout voltage	Typical	1.25 V (1.16 V at $I_F = 10 \text{ mA}$)		$I_F = 50 \text{ mA}$
	Maximum	1.5 V		
Output	On resistance	Typical	2.8 Ω	$I_F = 0 \text{ mA}$, $I_L = \text{Max.}$ Within 1 s on time
		Maximum	4.0 Ω	
	Off state leakage current	Maximum	10 μA	
Transfer characteristics	Operating (OFF) time*	Typical	3.9 ms	$I_F = 0 \rightarrow 10 \text{ mA}$ $I_L = 100 \text{ mA}$, $V_L = 10 \text{ V}$
		Maximum	7.5 ms	
		Typical	9.4 ms	$I_F = 0 \rightarrow 5 \text{ mA}$ $I_L = 100 \text{ mA}$, $V_L = 10 \text{ V}$
		Maximum	15 ms	
	Reverse (ON) time*	Typical	0.8 ms	$I_F = 5 \text{ mA} \rightarrow 0$ or $10 \text{ mA} \rightarrow 0$ $I_L = 100 \text{ mA}$, $V_L = 10 \text{ V}$
		Maximum	3.0 ms	
	I/O capacitance	Typical	0.8 pF	$f = 1 \text{ MHz}$ $V_B = 0 \text{ V}$
		Maximum	1.5 pF	
Initial I/O isolation resistance	Minimum	1,000 M Ω	500 V DC	
Maximum operating frequency	Maximum	—	0.5 cps	$I_F = 10 \text{ mA}$, Duty factor = 50% $I_L = \text{Max.}$, $V_L = \text{Max.}$

*Operate/Reverse time

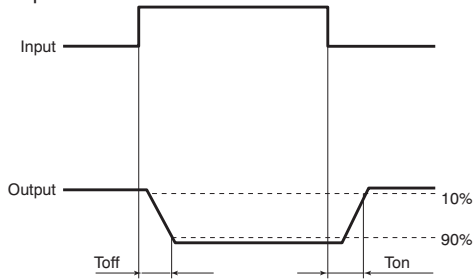

RECOMMENDED OPERATING CONDITIONS

Please obey the following conditions to ensure proper relay operation and resetting.

Item	Symbol	Recommended value	Unit
Input LED current	I_F	5 to 10	mA

■ For Dimensions, see page 63.

■ For Schematic and Wiring Diagrams, see page 68.

■ For Cautions for Use, see page 71.

■ These products are not designed for automotive use.

If you are considering to use these products for automotive applications, please contact your local Panasonic technical representative.

For more information, see page 80.

REFERENCE DATA

1. Load current vs. ambient temperature characteristics

Allowable ambient temperature: -40°C to $+85^\circ\text{C}$
 -40°F to $+185^\circ\text{F}$

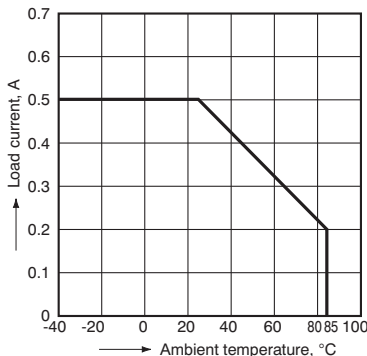

2. Load current vs. ambient temperature characteristics in adjacent mounting

I_L : Load current;
 I_L (max.): Maximum continuous load current

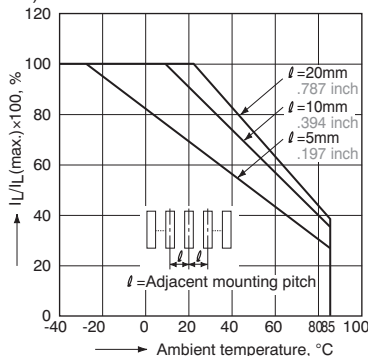

3. On resistance vs. ambient temperature characteristics

LED current: 0 mA; Load voltage: Max. (DC)
Continuous load current: Max. (DC)

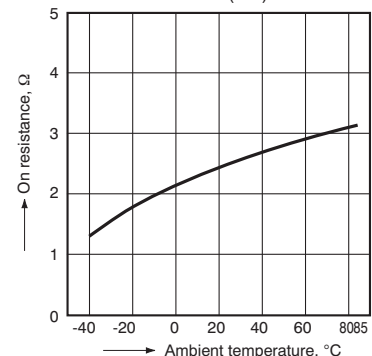

Power 1 Form B (AQZ404)

4. Operate (OFF) time vs. ambient temperature characteristics

LED current: 10 mA; Load voltage: 10 V (DC);
Continuous load current: 100 mA (DC)

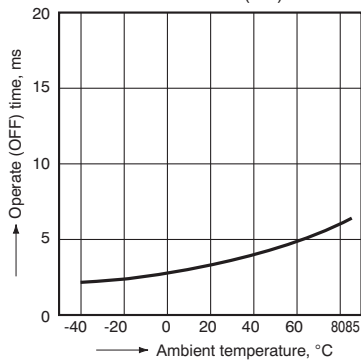

5. Reverse (ON) time vs. ambient temperature characteristics

LED current: 10 mA; Load voltage: 10 V (DC);
Continuous load current: 100 mA (DC)

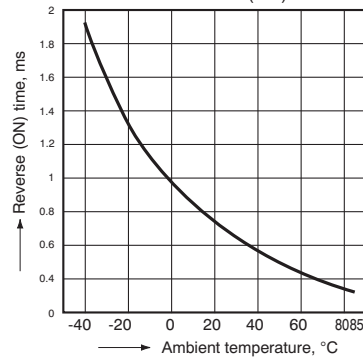

6. LED operate (OFF) current vs. ambient temperature characteristics

Load voltage: 10 V (DC);
Continuous load current: 100 mA (DC)

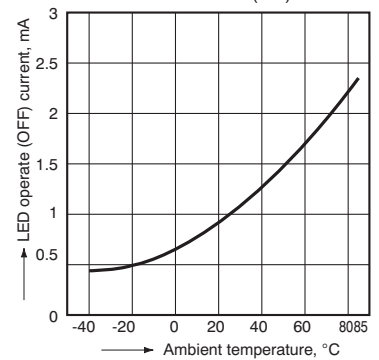

7. LED reverse (ON) current vs. ambient temperature characteristics

Load voltage: 10 V (DC);
Continuous load current: 100 mA (DC)

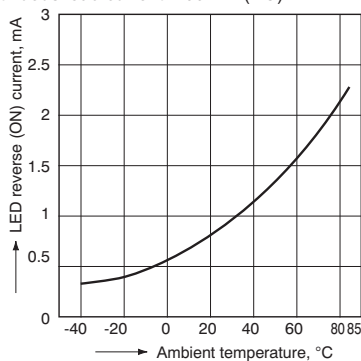

8. LED dropout voltage vs. ambient temperature characteristics

Sample: all types; LED current: 5 to 50 mA

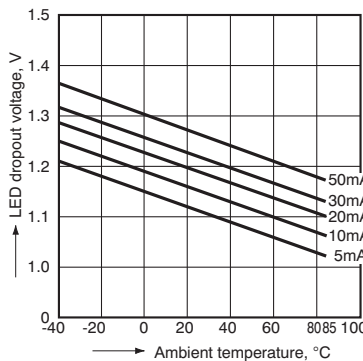

9. Current vs. voltage characteristics of output at MOS portion

Ambient temperature: 25°C 77°F

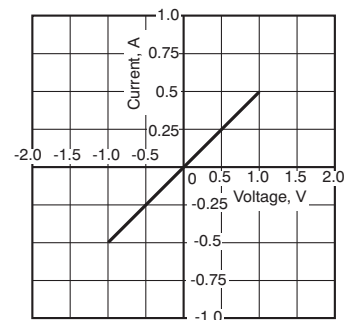

10. Off state leakage current vs. load voltage characteristics

Ambient temperature: 25°C 77°F

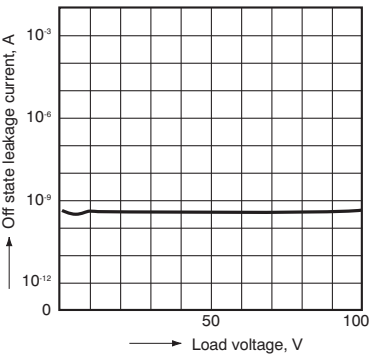

11. Operate (OFF) time vs. LED forward current characteristics

Load voltage: 10 V (DC); Continuous load current: 100 mA (DC); Ambient temperature: 25°C 77°F

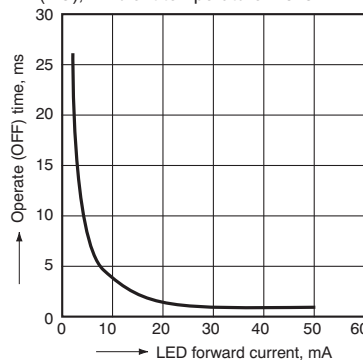

12. Reverse (ON) time vs. LED forward current characteristics

Load voltage: 10 V (DC); Continuous load current: 100 mA (DC); Ambient temperature: 25°C 77°F

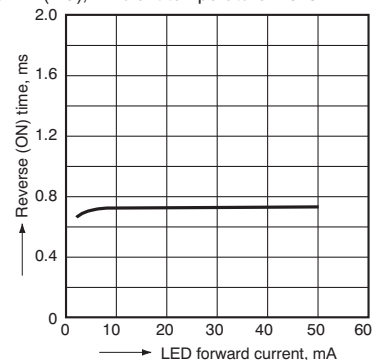

13. Maximum operating frequency vs. load voltage/current characteristics

LED current: 10 mA;
Ambient temperature: 25°C 77°F

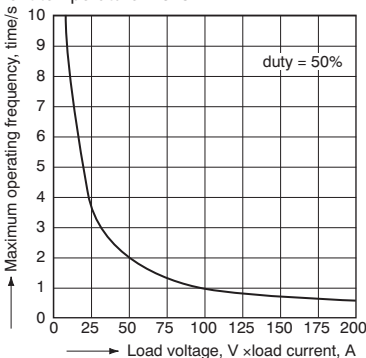

14. Output capacitance vs. applied voltage characteristics

Frequency: 1 MHz;
Ambient temperature: 25°C 77°F

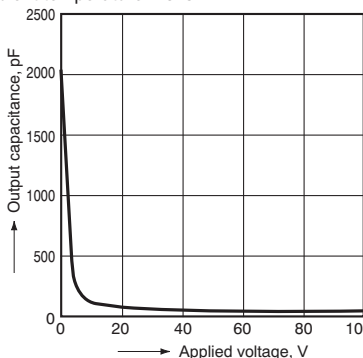

Power 1 Form B (AQZ404)

ACCESSORY (mm inch)

Socket

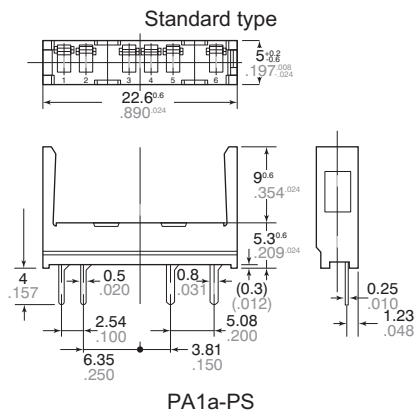

General Tolerance: $\pm 0.3 \pm .012$

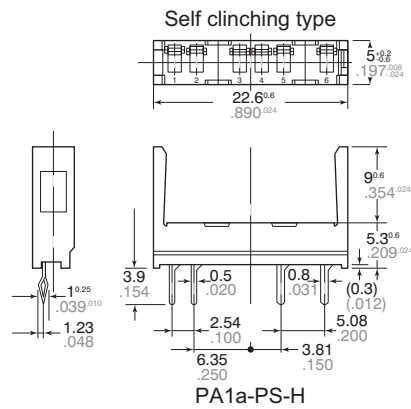

General Tolerance: $\pm 0.3 \pm .012$
PC board pattern
(BOTTOM VIEW)

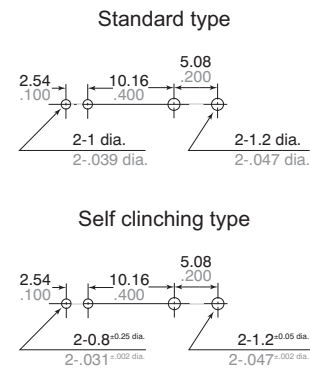

Tolerance: $\pm 0.1 \pm .004$

Panasonic

ideas for life



**Slim and high capacity
up to 3.6A
Voltage-driven type**

PhotoMOS®
1 Form A Voltage-sensitive
(AQZ100D, 200D)

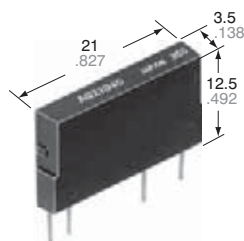

(Height includes standoff)

CAD Data

mm inch

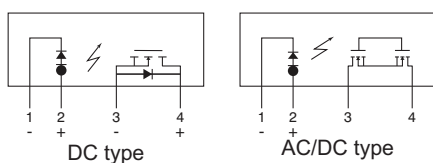

FEATURES

1. A voltage-sensitive power PhotoMOS relay

Conventional power PhotoMOS relays are connected externally to an input limiting resistor in order to obtain the appropriate LED current. Adding an internal constant-current element renders the input limiting resistor unnecessary, making it possible for the PhotoMOS relay to be voltage-driven.

2. Wide range of input voltages

Allows a wide range of input voltages from 4 to 30 V DC. The relay can be used in 5 V, 12 V or 24 V DC systems.

3. Both AC/DC dual types and DC-only types available

The AC/DC dual type is capable of bi-directional control, and unlike conventional SSRs, does not have to be used differently depending on the load. The DC-only type is well suited for control of DC solenoids and DC motors.

4. High capacity

Supports the various types of load control from very small loads to a max. 2.7 A for the AC/DC dual type, max. 3.6 A for the DC-only type.

5. High sensitivity and low on-resistance

Max. 3.6 A load can be controlled with the min. input voltage of 4 V DC. The on-resistance is also low at typ. 0.033 Ω (AQZ102D).

6. Slim SIL4-pin package

(W) 3.5 × (D) 21.0 × (H) 12.5 mm
(W) .138 × (D) .827 × (H) .492 inch
The compact size of the 4-pin SIL package allows high density mounting.

PhotoMOS

TYPES

1. DC type

	Output rating*		Package	Part No.	Packing quantity	
	Load voltage	Load current			Inner carton	Outer carton
DC only	60 V	3.6 A	SIL4-pin	AQZ102D	25 pcs.	500 pcs.
	100 V	2.3 A		AQZ105D		
	200 V	1.1 A		AQZ107D		
	400 V	0.6 A		AQZ104D		

* Load voltage and current of DC type: DC

2. AC/DC type

	Output rating*		Package	Part No.	Packing quantity	
	Load voltage	Load current			Inner carton	Outer carton
AC/DC dual use	60 V	2.7 A	SIL4-pin	AQZ202D	25 pcs.	500 pcs.
	100 V	1.8 A		AQZ205D		
	200 V	0.9 A		AQZ207D		
	400 V	0.45 A		AQZ204D		

* Load voltage and current of AC/DC type: Peak AC/DC

1 Form A Voltage-sensitive (AQZ100D, 200D)

RATING

1. DC type

1) Absolute maximum ratings (Ambient temperature: 25°C 77°F)

Item		Symbol	AQZ102D	AQZ105D	AQZ107D	AQZ104D	Remarks
Input	Input voltage	V_{IN}	30 V				
	Input reverse voltage	V_{RIN}	5 V				
	Power dissipation	P_{in}	300 mW				
Output	Load voltage (DC)	V_L	60 V	100 V	200 V	400 V	
	Continuous load current (DC)	I_L	3.6 A	2.3 A	1.1 A	0.6 A	
	Peak load current	I_{peak}	9.0 A	6.0 A	3.0 A	1.5 A	100 ms (1 shot), $V_L = DC$
	Power dissipation	P_{out}	1.35 W				
Total power dissipation		P_T	1.35 W				
I/O isolation voltage		V_{iso}	2,500 V AC				
Temperature limits	Operating	T_{opr}	-40°C to +85°C -40°F to +185°F (4 V q V_{IN} q 6 V) -40°C to +75°C -40°F to +167°F (6 V < V_{IN} q 15 V) -40°C to +60°C -40°F to +140°F (15 V < V_{IN} q 30 V)				Non-condensing at low temperatures
	Storage	T_{stg}	-40°C to +100°C -40°F to +212°F				

2) Electrical characteristics (Ambient temperature: 25°C 77°F)

Item		Symbol	AQZ102D	AQZ105D	AQZ107D	AQZ104D	Remarks
Input	Operate voltage	Typical	1.4 V				$I_L = 100$ mA $V_L = 10$ V
		Maximum	4 V				
	Turn off voltage	Minimum	0.8 V				$I_L = 100$ mA $V_L = 10$ V
		Typical	1.3 V				
Input current	Typical	$I_{IN} = 6.5$ mA				$V_{IN} = 5$ V	
Output	On resistance	Typical	0.033 Ω	0.090 Ω	0.33 Ω	1.23 Ω	$V_{IN} = 5$ V $I_L = Max.$ Within 1 s on time
		Maximum	0.09 Ω	0.17 Ω	0.55 Ω	1.6 Ω	
Off state leakage current	Maximum	I_{Leak}	10 μ A				$V_{IN} = 0$ V $V_L = Max.$
Transfer characteristics	Turn on time*	Typical	3.3 ms	2.2 ms	1.5 ms	1.2 ms	$V_{IN} = 5$ V $I_L = 100$ mA $V_L = 10$ V
		Maximum	10.0 ms				
	Turn off time*	Typical	0.2 ms		0.1 ms		$V_{IN} = 5$ V $I_L = 100$ mA $V_L = 10$ V
		Maximum	3.0 ms				
	I/O capacitance	Typical	$C_{iso} = 0.8$ pF				$f = 1$ MHz $V_B = 0$ V
		Maximum	1.5 pF				
Initial I/O isolation resistance	Minimum	R_{iso}	1,000 M Ω				500 V DC
Maximum operating speed	Maximum	—	0.5 cps				$V_{IN} = 5$ V Duty factor = 50% $I_L \times V_L = 200$ (VA)
Vibration resistance		Minimum	10 to 55 Hz at double amplitude of 3 mm				2 hours for 3 axes
Shock resistance		Minimum	4,900 m/s ² {500 G} 1 ms				3 times for 3 axes

2. AC/DC type

1) Absolute maximum ratings (Ambient temperature: 25°C 77°F)

Item		Symbol	AQZ202D	AQZ205D	AQZ207D	AQZ204D	Remarks
Input	Input voltage	V_{IN}	30 V				
	Input reverse voltage	V_{RIN}	5 V				
	Power dissipation	P_{in}	300 mW				
Output	Load voltage (peak AC)	V_L	60 V	100 V	200 V	400 V	
	Continuous load current	I_L	2.7 A	1.8 A	0.9 A	0.45 A	Peak AC, DC
	Peak load current	I_{peak}	9.0 A	6.0 A	3.0 A	1.5 A	100 ms (1 shot), $V_L = DC$
	Power dissipation	P_{out}	1.6 W				
Total power dissipation		P_T	1.6 W				
I/O isolation voltage		V_{iso}	2,500 V AC				
Temperature limits	Operating	T_{opr}	-40°C to +85°C -40°F to +185°F (4 V q V_{IN} q 6 V) -40°C to +75°C -40°F to +167°F (6 V < V_{IN} q 15 V) -40°C to +60°C -40°F to +140°F (15 V < V_{IN} q 30 V)				Non-condensing at low temperatures
	Storage	T_{stg}	-40°C to +100°C -40°F to +212°F				

1 Form A Voltage-sensitive (AQZ100D, 200D)

2) Electrical characteristics (Ambient temperature: 25°C 77°F)

Item		Symbol	AQZ202D	AQZ205D	AQZ207D	AQZ204D	Remarks
Input	Operate voltage	Typical	1.4 V				$I_L = 100 \text{ mA}$ $V_L = 10 \text{ V}$
		Maximum	4 V				
	Turn off voltage	Minimum	0.8 V				$I_L = 100 \text{ mA}$ $V_L = 10 \text{ V}$
Typical		1.3 V					
	Input current	Typical	6.5 mA				$V_{IN} = 5 \text{ V}$
Output	On resistance	Typical	0.066 Ω	0.180 Ω	0.64 Ω	2.4 Ω	$V_{IN} = 5 \text{ V}$ $I_L = \text{Max.}$ Within 1 s on time
		Maximum	0.18 Ω	0.34 Ω	1.1 Ω	3.2 Ω	
	Off state leakage current	Maximum	10 μA				$V_{IN} = 0 \text{ V}$ $V_L = \text{Max.}$
Transfer characteristics	Turn on time*	Typical	5.8 ms	4.2 ms	2.7 ms	2.3 ms	$V_{IN} = 5 \text{ V}$ $I_L = 100 \text{ mA}$ $V_L = 10 \text{ V}$
		Maximum	10.0 ms				
	Turn off time*	Typical	0.2 ms		0.1 ms		$V_{IN} = 5 \text{ V}$ $I_L = 100 \text{ mA}$ $V_L = 10 \text{ V}$
		Maximum	3.0 ms				
	I/O capacitance	Typical	0.8 pF				$f = 1 \text{ MHz}$ $V_B = 0 \text{ V}$
		Maximum	1.5 pF				
Initial I/O isolation resistance	Minimum	1,000 M Ω				500 V DC	
Maximum operating speed	Maximum	0.5 cps				$V_{IN} = 5 \text{ V}$ Duty factor = 50% $I_L \times V_L = 200 \text{ (VA)}$	
Vibration resistance	Minimum	10 to 55 Hz at double amplitude of 3 mm				2 hours for 3 axes	
Shock resistance	Minimum	4,900 m/s ² {500 G} 1 ms				3 times for 3 axes	

*Turn on/off time

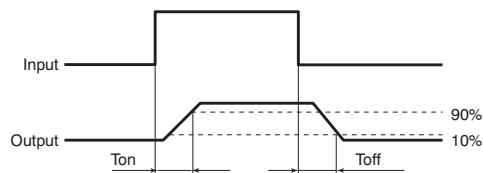

RECOMMENDED OPERATING CONDITIONS

Please obey the following conditions to ensure proper relay operation and resetting.

Item	Symbol	Recommended value	Unit
Input voltage	V_{IN}	5	V

- For Dimensions, see page 63.
- For Schematic and Wiring Diagrams, see page 67.
- For Cautions for Use, see page 71.

■ These products are not designed for automotive use.

If you are considering to use these products for automotive applications, please contact your local Panasonic technical representative.

For more information, see page 80.

1 Form A Voltage-sensitive (AQZ100D, 200D)

REFERENCE DATA

1. Load current vs. ambient temperature characteristics

Allowable ambient temperature: -40°C to $+85^{\circ}\text{C}$
 -40°F to $+185^{\circ}\text{F}$;

V_{IN} : Input voltage; I_L (derate): Load current (derate); I_L : Absolute maximum ratings of continuous load current

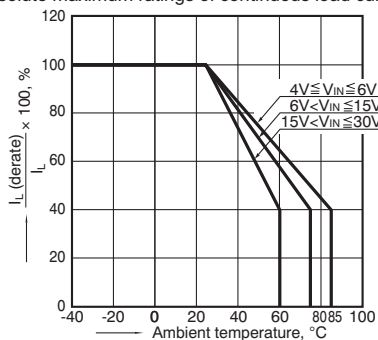

2-(1) Load current vs. ambient temperature characteristics in adjacent mounting

Input voltage: $4\text{V} \leq V_{\text{IN}} \leq 6\text{V}$;
 I_L (derate): Load current (derate); I_L : Absolute maximum ratings of continuous load current; ℓ : Adjacent mounting pitch

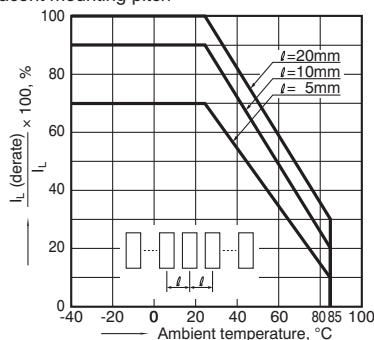

2-(2) Load current vs. ambient temperature characteristics in adjacent mounting

Input voltage: $6\text{V} < V_{\text{IN}} \leq 15\text{V}$;
 I_L (derate): Load current (derate); I_L : Absolute maximum ratings of continuous load current; ℓ : Adjacent mounting pitch

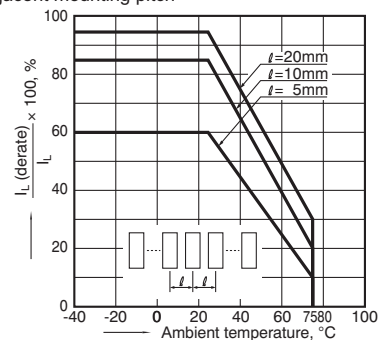

2-(3) Load current vs. ambient temperature characteristics in adjacent mounting

Input voltage: $15\text{V} < V_{\text{IN}} \leq 30\text{V}$;
 I_L (derate): Load current (derate); I_L : Absolute maximum ratings of continuous load current; ℓ : Adjacent mounting pitch

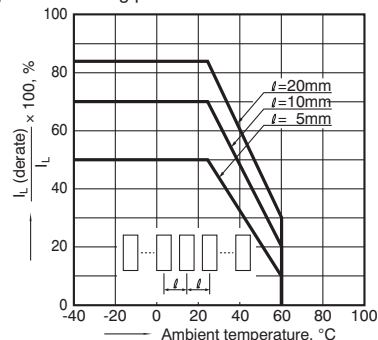

3-(1) On resistance vs. ambient temperature characteristics (DC type)

Input voltage: 5 V;
 Continuous load current: 3.6 A (DC) (AQZ102D)
 2.3 A (DC) (AQZ105D)

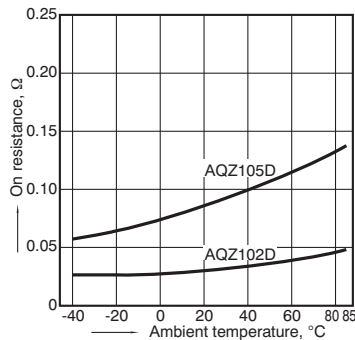

3-(2) On resistance vs. ambient temperature characteristics (DC type)

Input voltage: 5 V;
 Continuous load current: 1.1 A (DC) (AQZ107D)
 0.6 A (DC) (AQZ104D)

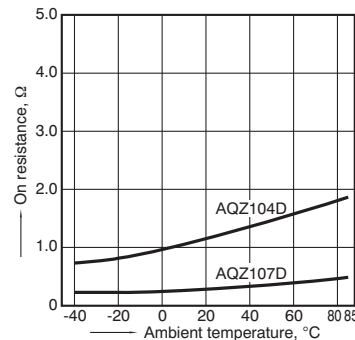

3-(3) On resistance vs. ambient temperature characteristics (AC/DC type)

Input voltage: 5 V;
 Continuous load current: 2.7 A (DC) (AQZ202D)
 1.8 A (DC) (AQZ205D)

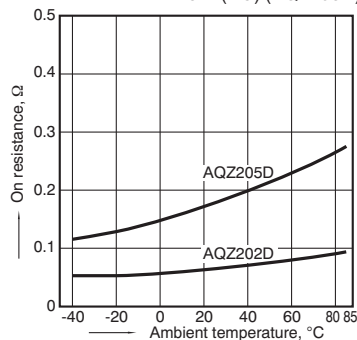

3-(4) On resistance vs. ambient temperature characteristics (AC/DC type)

Input voltage: 5 V;
 Continuous load current: 0.9 A (DC) (AQZ207D)
 0.45 A (DC) (AQZ204D)

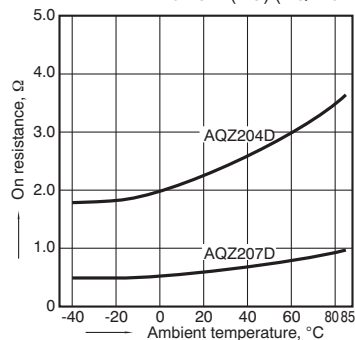

4-(1) Turn on time vs. ambient temperature characteristics (DC type)

Input voltage: 5 V; Load voltage: 10 V (DC);
 Continuous load current: 100 mA (DC)

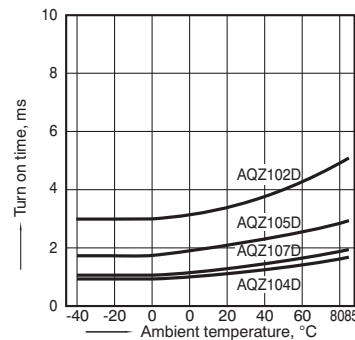

1 Form A Voltage-sensitive (AQZ100D, 200D)

4.-(2) Turn on time vs. ambient temperature characteristics (AC/DC type)

Input voltage: 5 V;
Load voltage: 10 V (DC);
Continuous load current: 100 mA (DC)

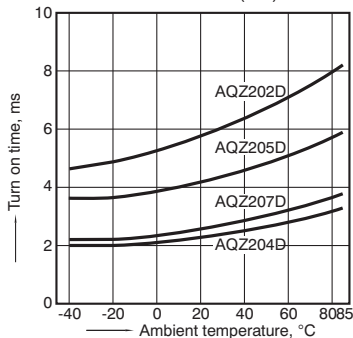

5.-(1) Turn off time vs. ambient temperature characteristics (DC type)

Input voltage: 5 V; Load voltage: 10 V (DC);
Continuous load current: 100 mA (DC)

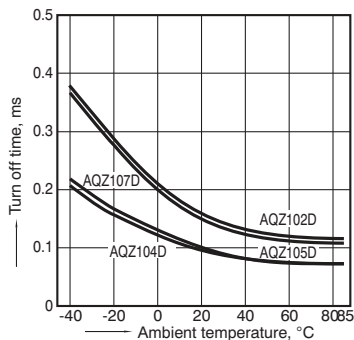

5.-(2) Turn off time vs. ambient temperature characteristics (AC/DC type)

Input voltage: 5 V; Load voltage: 10 V (DC);
Continuous load current: 100 mA (DC)

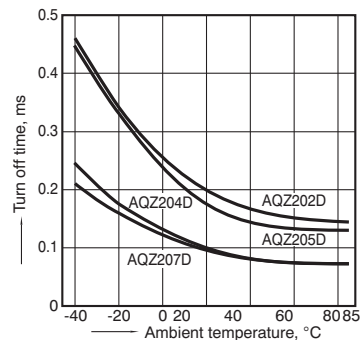

6. Operate voltage vs. ambient temperature characteristics

Load voltage: 10 V (DC);
Continuous load current: 100 mA (DC)

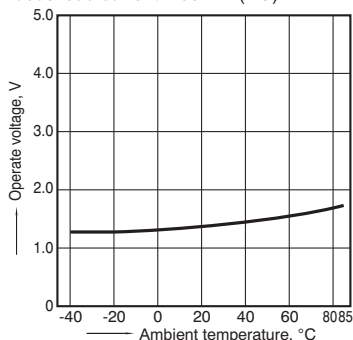

7. Turn off voltage vs. ambient temperature characteristics

Load voltage: 10 V (DC);
Continuous load current: 100 mA (DC)

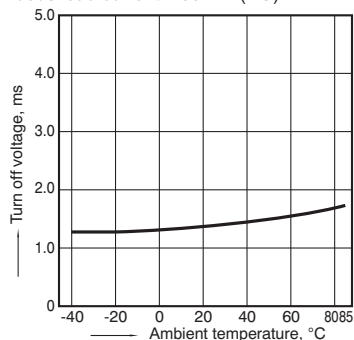

8. Input current vs. ambient temperature characteristics

Input voltage: 5 V

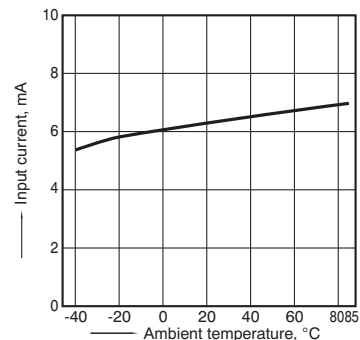

9.-(1) Current vs. voltage characteristics of output at MOS portion (DC type)

Ambient temperature: 25°C 77°F

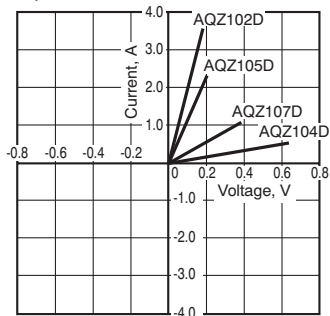

9.-(2) Current vs. voltage characteristics of output at MOS portion (AC/DC type)

Ambient temperature: 25°C 77°F

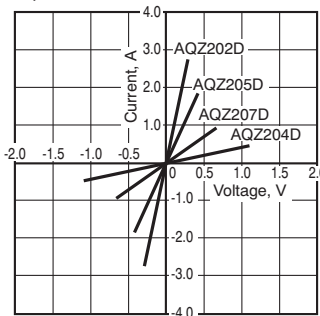

10. Input current vs. input voltage characteristics

Ambient temperature: 25°C 77°F

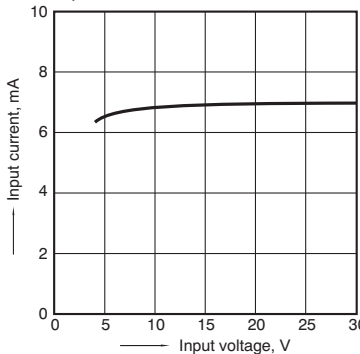

11.-(1) Off state leakage current vs. load voltage characteristics

Ambient temperature: 25°C 77°F

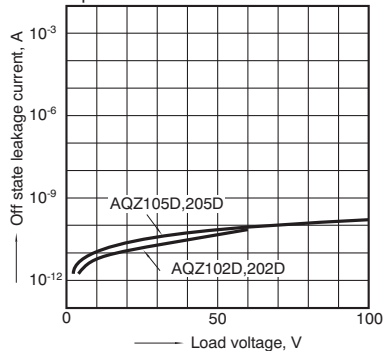

11.-(2) Off state leakage current vs. load voltage characteristics

Ambient temperature: 25°C 77°F

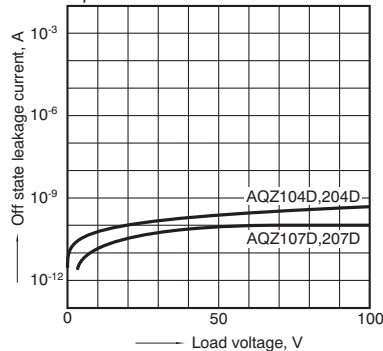

12. Maximum operating speed vs. load voltage × load current characteristics

Input voltage: 5V; Ambient temperature: 25°C 77°F

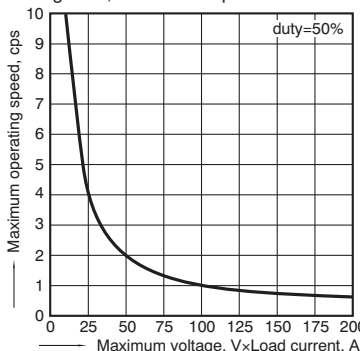

PhotoMOS

1 Form A Voltage-sensitive (AQZ100D, 200D)

13-(1) Output capacitance vs. applied voltage characteristics (DC type)

Frequency: 1 MHz; Ambient temperature: 25°C 77°F

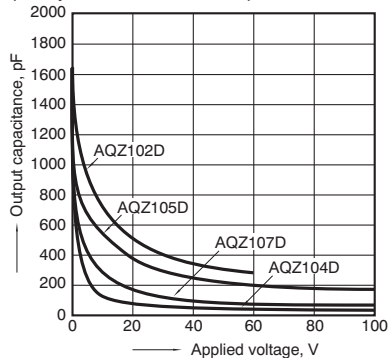

13-(2) Output capacitance vs. applied voltage characteristics (AC/DC type)

Frequency: 1 MHz; Ambient temperature: 25°C 77°F

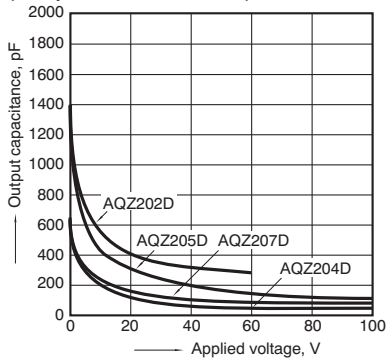

ACCESSORY (mm inch)

Socket

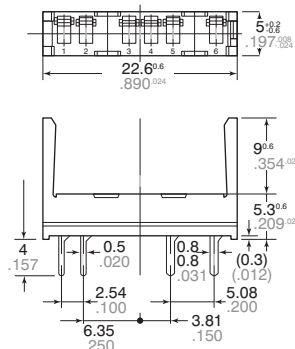

PA1a-PS

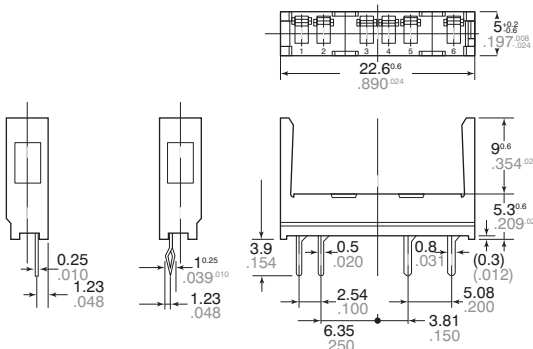

PA1a-PS-H

Standard type

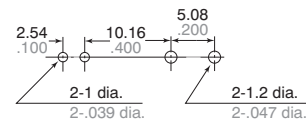

Self clinching type

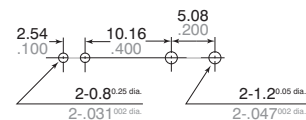

Tolerance: ±0.1 ±.004

Panasonic

ideas for life

High capacity up to 6A
in a slim SIL package

PhotoMOS®
Power 1 Form A
High Capacity (AQZ26○)

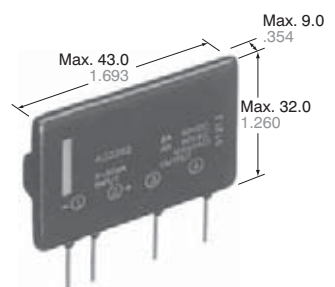

(Height includes
standoff)

CAD Data

mm inch

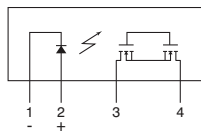

FEATURES

1. High capacity type power PhotoMOS relay.

Can switch a wide range of currents and voltages. Can control various types of loads, from very small loads to a max. 6A AC/DC current for sequencers, motors, and lamps.

2. Low on-resistance and high sensitivity.

Low on-resistance of less than typ. 0.036Ω (AQZ262). High sensitivity LED operate current of typ. 1 mA.

3. AC/DC dual use

Bi-directional control is possible. There is no need to differentiate depending on the load as was necessary with the conventional SSR.

4. 4-pin SIL type

(L) 43.0 mm × (W) 9.0 mm × (H) 32.0 mm
(L) 1.693 inch × (W) .354 inch × (H) 1.260 inch.

5. Low-level off state leakage current of max. 10 μ A

6. Controls low-level analog signals

The triac, photocoupler, or SSR cannot be used to control signals of less than several hundred mV. The high capacity type power PhotoMOS relay feature extremely low closed-circuit offset voltage to enable control of low-level analog signals without distortion.

TYPICAL APPLICATIONS

- Mercury relay replacement
- Compact motors, lamps, heaters
- OA equipment

TYPES

	Output rating*		Package	Part No.	Packing quantity	
	Load voltage	Load current			Inner carton	Outer carton
AC/DC dual use	60 V	6.0 A	SIL4-pin	AQZ262	20 pcs	200 pcs
	400 V	1.0 A		AQZ264		

* Indicate the peak AC and DC values.

RATING

1. Absolute maximum ratings (Ambient temperature: 25°C 77°F)

Item		Symbol	AQZ262	AQZ264	Remarks
Input	LED forward current	I_F	50 mA		
	LED reverse voltage	V_R	5 V		
	Peak forward current	I_{FP}	1 A		$f = 100\text{Hz}$, Duty factor = 0.1%
	Power dissipation	P_{in}	75 mW		
Output	Load voltage (peak AC)	V_L	60 V	400 V	
	Continuous load current	I_L	6.0 A	1.0 A	Peak AC, DC
	Peak load current	I_{peak}	10.0 A	3.0 A	100 ms (1shot), $V_L = \text{DC}$
	Power dissipation	P_{out}	3.0 W		
Total power dissipation		P_T	3.0 W		
I/O isolation voltage		V_{iso}	1,500 V AC		
Temperature limits	Operating	T_{opr}	-40°C to +85°C -40°F to 185°F		Non-condensing at low temperatures
	Storage	T_{stg}	-40°C to +100°C -40°F to 212°F		

Power 1 Form A High Capacity (AQZ26○)

2. Electrical characteristics (Ambient temperature: 25°C 77°F)

Item			Symbol	AQZ262	AQZ264	Remarks
Input	LED operate current	Typical	I_{Fon}	1.0 mA		$I_L = 100 \text{ mA}$ $V_L = 10 \text{ V}$
		Maximum		3.0 mA		
	LED turn off current	Minimum	I_{Foff}	0.4 mA		$I_L = 100 \text{ mA}$ $V_L = 10 \text{ V}$
		Typical		0.9 mA		
LED dropout voltage	Typical	V_F	1.25 V (1.16 V at $I_F = 10 \text{ mA}$)		$I_F = 50 \text{ mA}$	
	Maximum		1.5 V			
Output	On resistance	Typical	R_{on}	0.036 Ω	1.0 Ω	$I_F = 10 \text{ mA}$ $I_L = \text{max.}$ Within 1 s on time
		Maximum		0.05 Ω	1.4 Ω	
	Off state leakage current	Maximum	I_{Leak}	10 μA		$I_F = 0 \text{ mA}$ $V_L = \text{max.}$
Transfer characteristics	Turn on time*	Typical	T_{on}	5 ms	4 ms	$I_F = 10 \text{ mA}$ $I_L = 100 \text{ mA}$ $V_L = 10 \text{ V}$
		Maximum		10 ms		
	Turn off time*	Typical	T_{off}	0.32 ms	0.14 ms	$I_F = 10 \text{ mA}$ $I_L = 100 \text{ mA}$ $V_L = 10 \text{ V}$
		Maximum		3.0 ms		
	I/O capacitance	Typical	C_{iso}	2.0 pF		$f = 1 \text{ MHz}$ $V_B = 0 \text{ V}$
		Maximum		4.0 pF		
Initial I/O isolation resistance	Minimum	R_{iso}	1,000 M Ω		500 V DC	
Maximum operating frequency	Maximum	—	0.5 cps		$I_F = 10 \text{ mA}$ Duty factor = 50% $I_L = \text{Max.}, V_L = \text{Max.}$	

*Turn on/off time

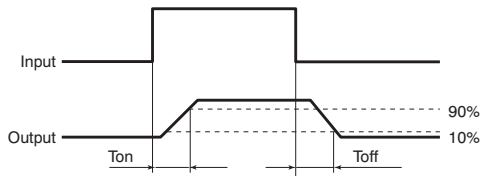

RECOMMENDED OPERATING CONDITIONS

Please obey the following conditions to ensure proper relay operation and resetting.

Item	Symbol	Recommended value	Unit
Input LED current	I_F	5 to 10	mA

■ For Dimensions, see page 63.

■ For Schematic and Wiring Diagrams, see page 67.

■ For Cautions for Use, see page 71.

■ These products are not designed for automotive use.

If you are considering to use these products for automotive applications, please contact your local Panasonic technical representative.

For more information, see page 80.

REFERENCE DATA

1. Load current vs. ambient temperature characteristics

Allowable ambient temperature: -40°C to +85°C
-40°F to +185°F

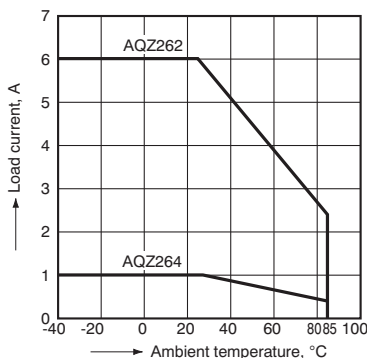

2. Load current vs. ambient temperature characteristics in adjacent mounting

I_L : Load current;
 $I_L(\text{max.})$: Maximum continuous load current

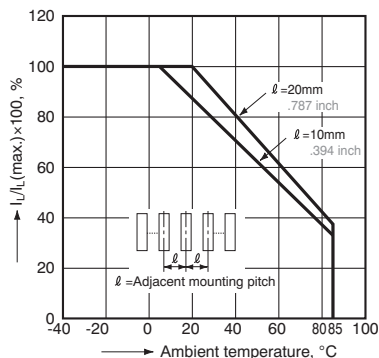

3. On resistance vs. ambient temperature characteristics

LED current: 10 mA;
Continuous load current: 6A (DC)(AQZ262)
1A (DC)(AQZ264)

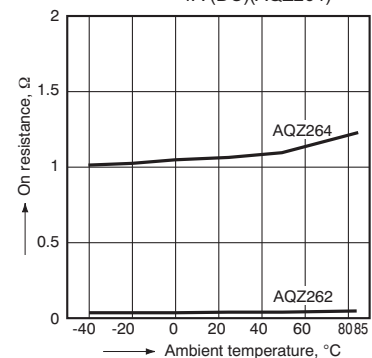

Power 1 Form A High Capacity (AQZ26○)

4. Turn on time vs. ambient temperature characteristics

LED current: 10 mA; Load voltage: 10 V (DC);
Continuous load current: 100 mA (DC)

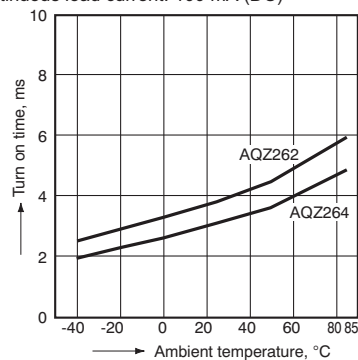

5. Turn off time vs. ambient temperature characteristics

LED current: 10 mA; Load voltage: 10 V (DC);
Continuous load current: 100 mA (DC)

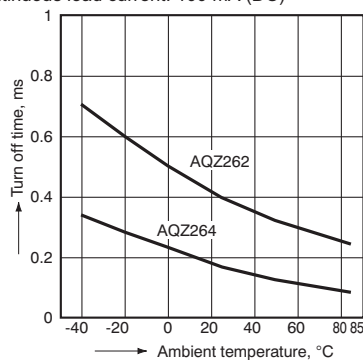

6. LED operate vs. ambient temperature characteristics

Load voltage: 10 V (DC);
Continuous load current: 100 mA (DC)

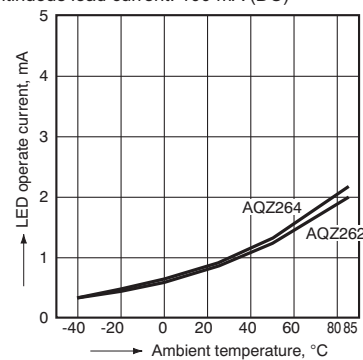

7. LED turn off current vs. ambient temperature characteristics

Load voltage: 10 V (DC);
Continuous load current: 100 mA (DC)

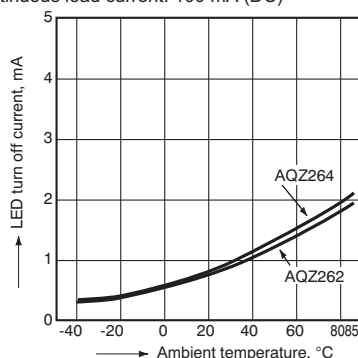

8. LED dropout voltage vs. ambient temperature characteristics

Sample: all types; LED current: 5 to 50 mA

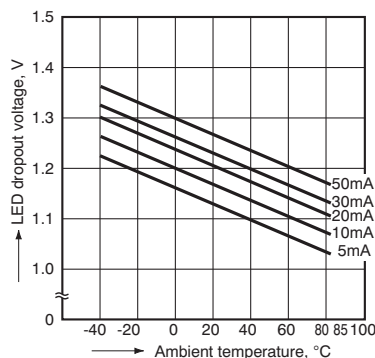

9. Current vs. voltage characteristics of output at MOS portion

Ambient temperature: 25°C 77°F

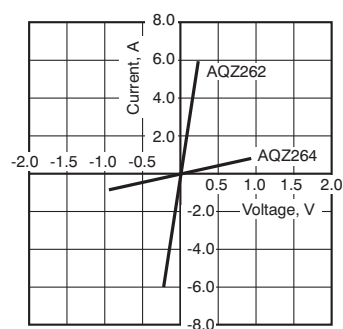

10. Off state leakage current vs. load voltage characteristics

Ambient temperature: 25°C 77°F

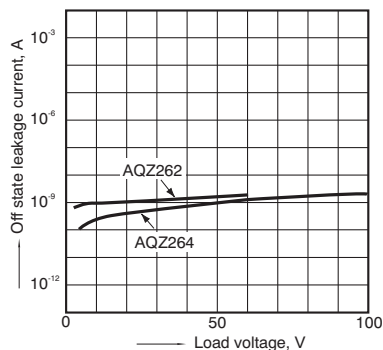

11. Turn on time vs. LED forward current characteristics

Load voltage: 10 V (DC); Continuous load current: 100 mA (DC); Ambient temperature: 25°C 77°F

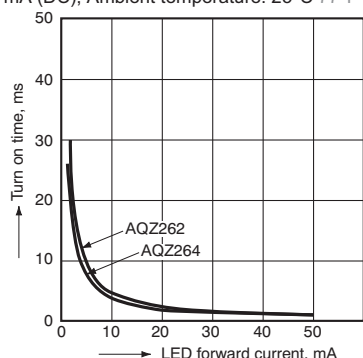

12. Turn off time vs. LED forward current characteristics

Load voltage: 10 V (DC); Continuous load current: 100 mA (DC); Ambient temperature: 25°C 77°F

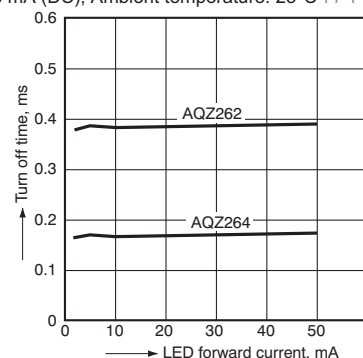

13. Maximum operating frequency vs. load voltage/current characteristics

LED current: 10 mA; Ambient temperature: 25°C 77°F

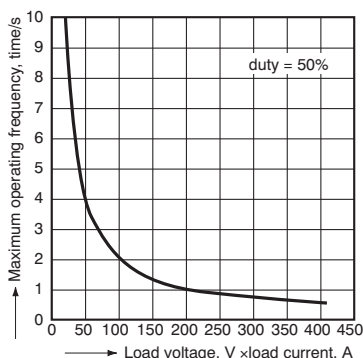

14. Output capacitance vs. applied voltage characteristics

Frequency: 10 KHz; Ambient temperature: 25°C 77°F

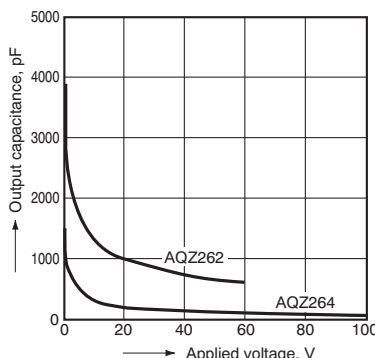

15-(1) On resistance distribution

Sample: AQZ262

LED current: 10 mA; Continuous load current: 6 A (DC);
Quantity: n=100; Ambient temperature: 25°C 77°F

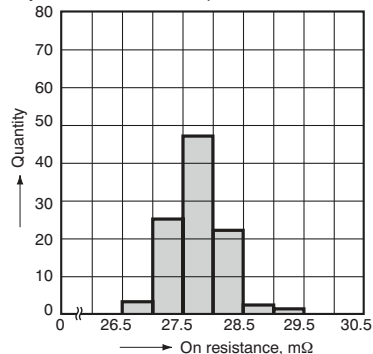

Power 1 Form A High Capacity (AQZ260)

15.- (2) On resistance distribution

Sample: AQZ264
 LED current: 10 mA;
 Continuous load current: 1 A (DC); Quantity, n=100;
 Ambient temperature: 25°C 77°F

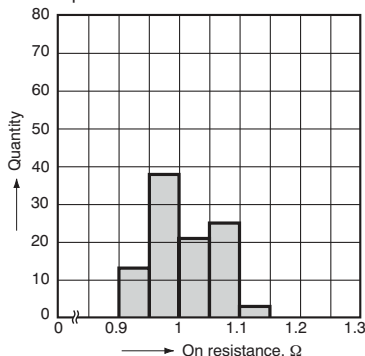

16.- (1) Turn on time distribution

Sample: AQZ262
 Load voltage: 10 V (DC); Continuous load current:
 100 mA (DC); Quantity, n=100;
 Ambient temperature: 25°C 77°F

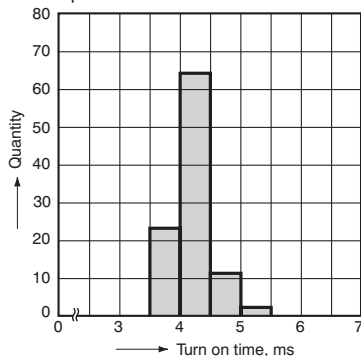

16.- (2) Turn on time distribution

Sample: AQZ264
 Load voltage: 10 V (DC); Continuous load current:
 100 mA (DC); Quantity, n=100;
 Ambient temperature: 25°C 77°F

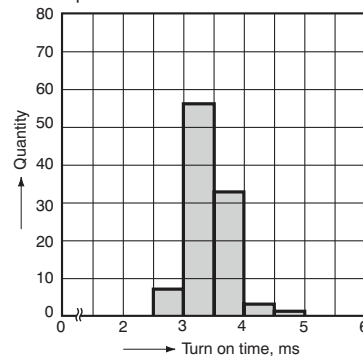

17.- (1) Turn off time distribution

Sample: AQZ262
 Load voltage: 10 V (DC); Continuous load current:
 100 mA (DC); Quantity, n=100;
 Ambient temperature: 25°C 77°F

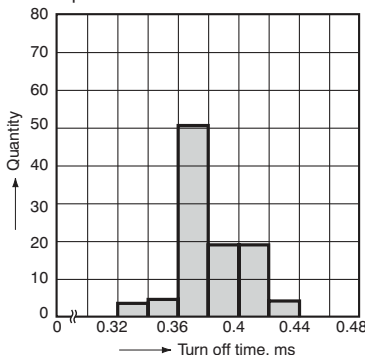

17.- (2) Turn off time distribution

Sample: AQZ264
 Load voltage: 10 V (DC); Continuous load current:
 100 mA (DC); Quantity, n=100;
 Ambient temperature: 25°C 77°F

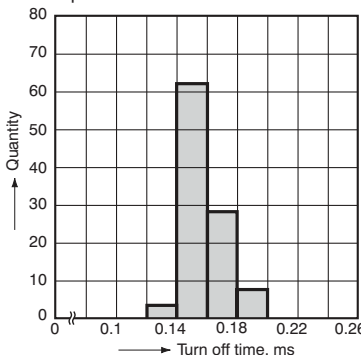

18.- (1) LED operate current distribution

Sample: AQZ262
 Load voltage: 10 V (DC); Continuous load current:
 100 mA (DC); Quantity, n=100;
 Ambient temperature: 25°C 77°F

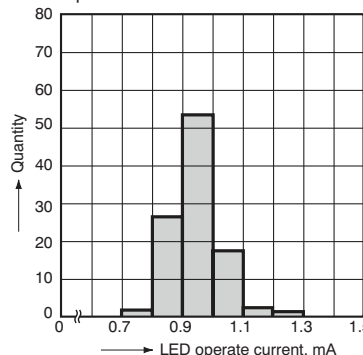

18.- (2) LED operate current distribution

Sample: AQZ264
 Load voltage: 10 V (DC); Continuous load current:
 100 mA (DC); Quantity, n=100;
 Ambient temperature: 25°C 77°F

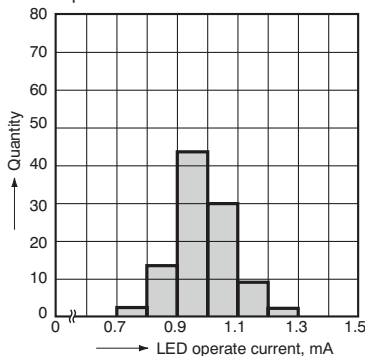

19.- (1) LED turn off current distribution

Sample: AQZ262
 Load voltage: 10 V (DC); Continuous load current:
 100 mA (DC); Quantity, n=100;
 Ambient temperature: 25°C 77°F

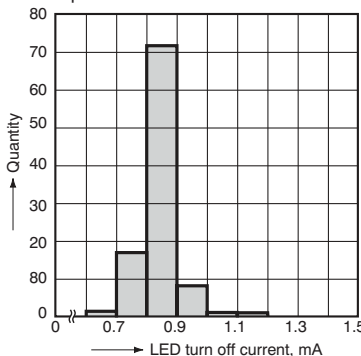

19.- (2) LED turn off current distribution

Sample: AQZ264
 Load voltage: 10 V (DC); Continuous load current:
 100 mA (DC); Quantity, n=100;
 Ambient temperature: 25°C 77°F

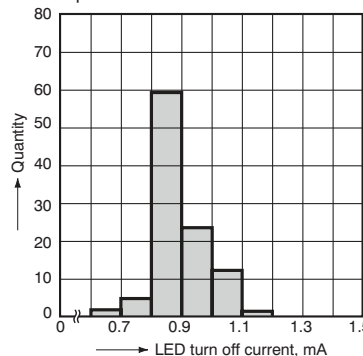

20.- (1) LED dropout voltage distribution

Sample: AQZ262
 LED current: 50 mA; Quantity, n=100;
 Ambient temperature: 25°C 77°F

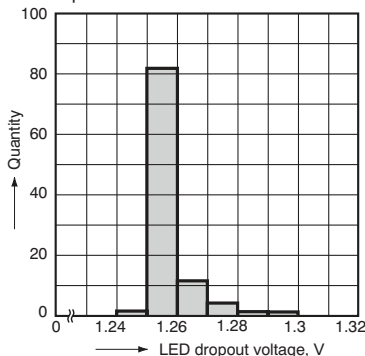

20.- (2) LED dropout voltage distribution

Sample: AQZ264
 LED current: 50 mA; Quantity, n=100;
 Ambient temperature: 25°C 77°F

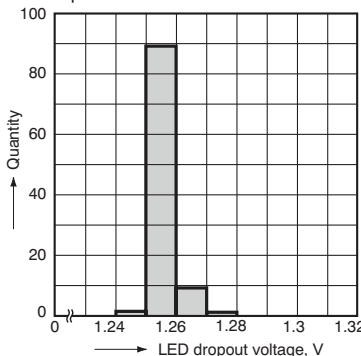

21.- (1) Bias test at high temperature and high humidity (change of turn on time)

Quantity, n=10; Ambient temperature: 85°C 185°F
 Humidity: 85%, VL=Max. × 0.8

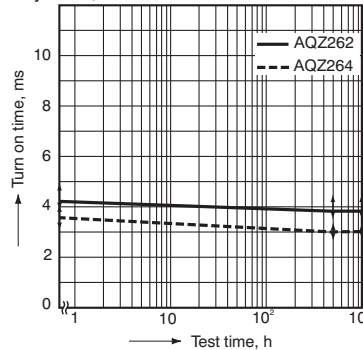

Power 1 Form A High Capacity (AQZ26○)

21.-(2) Bias test at high temperature and high humidity (change of on resistance)

Quantity, n=10; Ambient temperature: 85 °C 185°F
Humidity: 85%, VL=Max. × 0.8

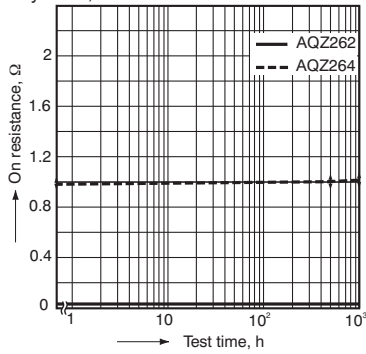

22.-(1) Low temperature storage test (change of turn on time)

Quantity, n=10; Ambient temperature: -40°C -40°F

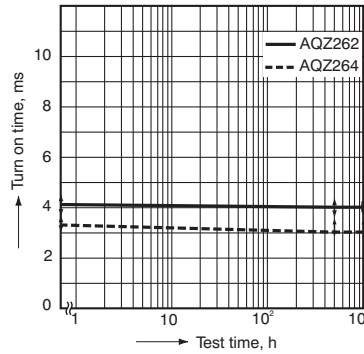

22.-(2) Low temperature storage test (change of on resistance)

Quantity, n=10; Ambient temperature: -40°C -40°F

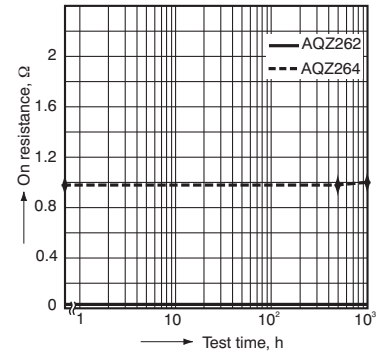

23.-(1) High temperature storage test (change of turn on time)

Quantity, n=10; Ambient temperature: 100°C 212°F

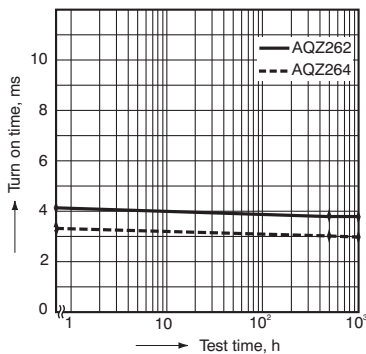

23.-(2) High temperature storage test (change of on resistance)

Quantity, n=10; Ambient temperature: 100°C 212°F

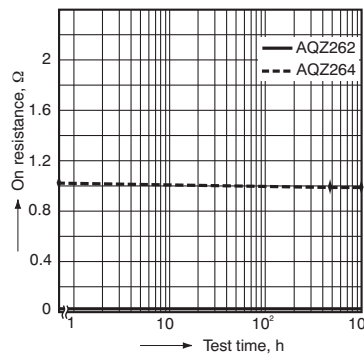

Panasonic

ideas for life



Photovoltaic MOSFET drivers of wide variation

Photovoltaic MOSFET Driver (APV1, 2)



CAD Data

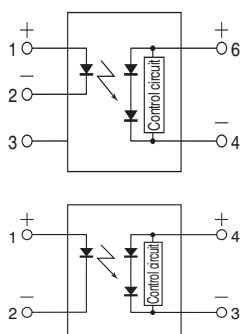

FEATURES

1. High-speed switching

Since release time is typ.0.1 ms, the MOSFET can be turned off quickly in urgent situations.

2. Space saving

With a built-in control circuit, an external resistor is not needed. This contributes to making substrates more compact.

3. High insulation

DIP type: 5,000 V

SOP type: 2,500 V

SSOP type: 1,500 V

4. Extensive product lineup

Products include SSOP, SOP4-pin and DIP6-pin.

TYPICAL APPLICATIONS

- Power supply (Vcc) for electronic circuits
- Driving MOSFET

TYPES

Output rating		Package	Part No.				Packing quantity	
Drop-out voltage (Typ.)	Short circuit current (Typ.)		Through hole terminal	Surface-mount terminal			Tube	Tape and reel
			Tube packing style	Tube packing style	Tape and reel packing style			
					Picked from 1/2/3-pin side*1	Picked from 4/5/6-pin side*2		
8.7V	14 μ A	DIP6-pin	APV1122	APV1122A	APV1122AX	APV1122AZ	1 tube contains 50 pcs. 1 batch contains 500 pcs.	1,000 pcs.
8.7V	14 μ A	SOP4-pin*3	—	APV1121S	APV1121SX	APV1121SZ	1 tube contains 100 pcs. 1 batch contains 2,000 pcs.	
8.2V	8 μ A		—	—	APV2121S	APV2121SX	APV2121SZ	
8.2V	8 μ A	SSOP*4	—	—	APV2111VY	APV2111VW	—	3,500 pcs.

Notes: *1 SOP type is picked from 1/2-pin side, SSOP type is picked from 1/4-pin side.

*2 SOP type is picked from 3/4-pin side, SSOP type is picked from 2/3-pin side.

*3 For space reasons, the two initial letters of the part number "AP", package (SOP) indicator "S" and the packing style indicator "X" or "Z" are not marked on the relay. (Ex. the label for product number APV1121SX is V1121).

*4 Tape and reel package is the standard packing style.

For space reasons, the two initial letters of the part number "AP", package (SSOP) indicator "V" and the packing style are not marked on the relay. (Ex. the label for product number APV2111VY is V2111).

RATING

1. Absolute maximum ratings (Ambient temperature: 25°C 77°F)

Item		Symbol	APV1122(A)	APV1121S	APV2121S	APV2111V	Remarks
Input	LED forward current	I _F	50mA				
	LED reverse voltage	V _R	5V				
	Peak forward current	I _{FP}	1A				f = 100 Hz, Duty Ratio = 0.1%
	Power dissipation	P _{in}	75mW				
I/O isolation voltage		V _{iso}	5,000V AC	2,500V AC	2,500V AC	1,500V AC	
Temperature limits	Operating	T _{opr}	-40°C to +85°C -40°F to +185°F				Non-condensing at low temperatures
	Storage	T _{stg}	-40°C to +100°C -40°F to +212°F				

(APV1, 2)

2. Electrical characteristics (Ambient temperature: 25°C 77°F)

Item		Symbol	APV1122(A)	APV1121S	APV2121S	APV2111V	Condition
Input	LED operate current	Typical	0.6mA		0.85mA		$V_{OC} = 5V$
		Maximum	3mA				
	LED turn off current	Minimum	0.2mA				$V_{OC} = 1V$
		Typical	0.5mA		0.75mA		
LED dropout voltage	Typical	1.15V				$I_F = 10mA$	
	Maximum	1.5V					
Output	Drop-out voltage*	Minimum	6V		5V		$I_F = 10mA$
		Typical	8.7V		8.2V		
	Short circuit current**	Minimum	5 μ A		3 μ A		$I_F = 10mA$
		Typical	14 μ A		8 μ A		
Transfer characteristics	Turn on time***	Typical	0.4ms		0.8ms		$I_F = 10mA$, $C_L = 1,000pF$
	Turn off time***	Typical	0.1ms				
	I/O capacitance	Typical	0.8pF				$V_B = 0V$, $f = 1MHz$
		Maximum	1.5pF				
Initial I/O isolation resistance	Minimum	R_{iso}	1,000M Ω			500V DC	

Note: Recommended LED forward current I_{FT} : 10mA.

*Drop-out voltage measurement circuit

APV1122(A)

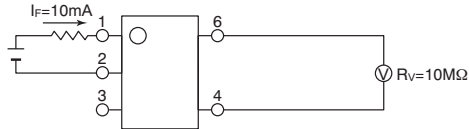

APV1121S, APV2121S, APV2111V

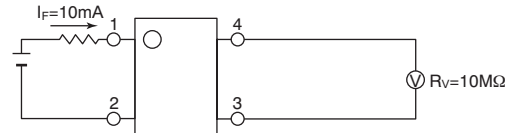

**Short circuit current measurement circuit

APV1122(A)

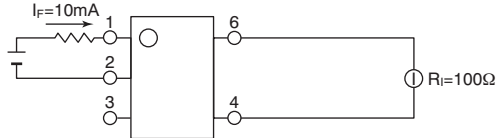

APV1121S, APV2121S, APV2111V

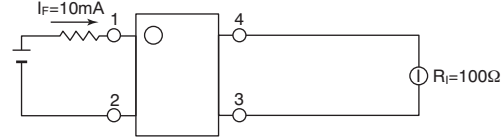

***Turn on/Turn off time measurement circuit

APV1122(A)

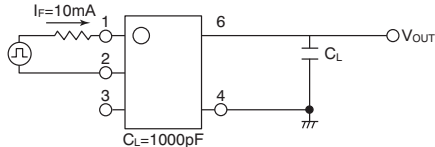

APV1121S, APV2121S, APV2111V

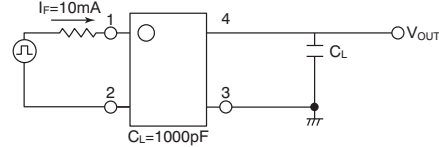

***Turn on time

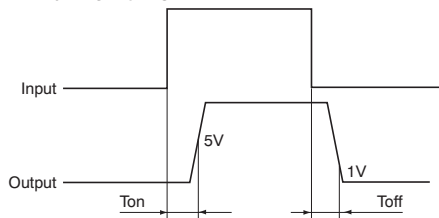

RECOMMENDED OPERATING CONDITIONS

Please obey the following conditions to ensure proper relay operation and resetting.

Item	Symbol	Recommended value	Unit
Input LED current	I_F	10	mA

■ For Dimensions, see page 60.

■ For Schematic and Wiring Diagrams, see page 68.

■ For Cautions for Use, see page 71.

■ These products are not designed for automotive use.

If you are considering to use these products for automotive applications, please contact your local Panasonic technical representative.

For more information, see page 80.

(APV1, 2)

REFERENCE DATA

1. Drop-out voltage vs. ambient temperature characteristics

Input current: 10mA

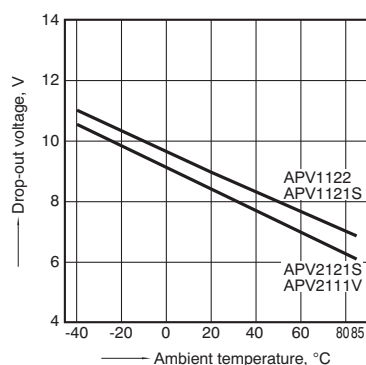

2. Short circuit current vs. ambient temperature characteristics

Input current: 10mA

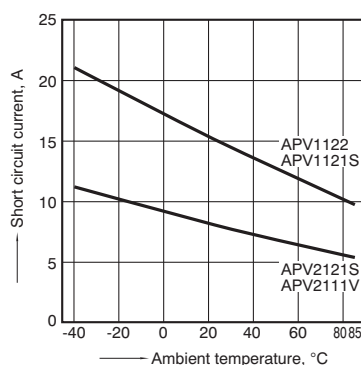

3. LED operate current vs. ambient temperature characteristics

Drop-out voltage: 5V

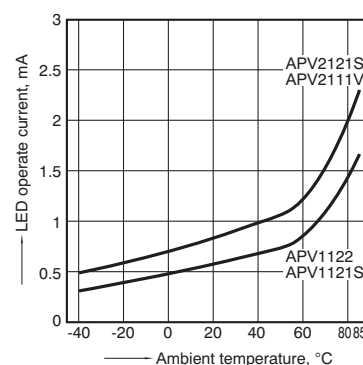

4. LED turn off current vs. ambient temperature characteristics

Drop-out voltage: 1V

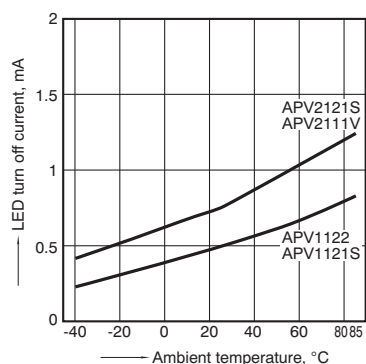

5. LED dropout voltage vs. ambient temperature characteristics

LED forward current: 5 to 50mA

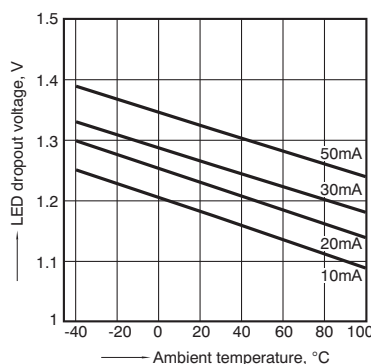

6. Turn on time vs. ambient temperature characteristics

LED forward current: 10mA

Load capacity: 1,000pF; output voltage: 5V

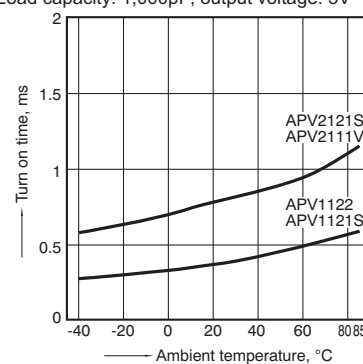

7. Turn off time vs. ambient temperature characteristics

LED forward current: 10mA

Load capacity: 1,000pF; output voltage: 1V

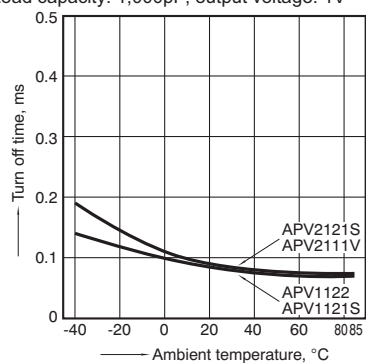

8. Turn on time vs. LED forward current characteristics

Load capacity: 1,000pF; output voltage: 5V

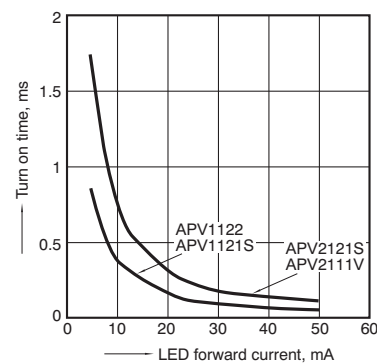

9. Turn off time vs. LED forward current characteristics

Load capacity: 1,000pF; output voltage: 1V

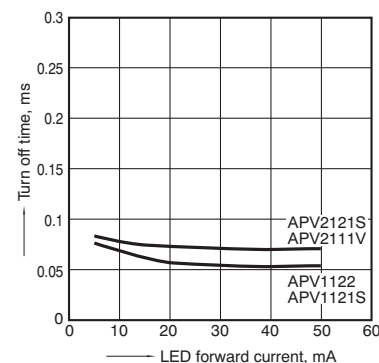

10. Drop-out voltage vs. LED forward current characteristics

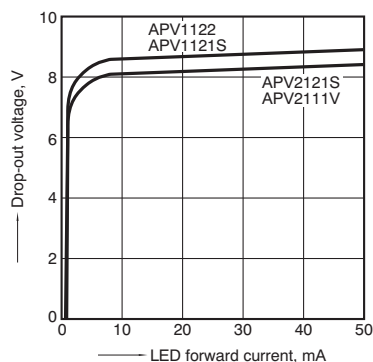

11. Short circuit current vs. LED forward current characteristics

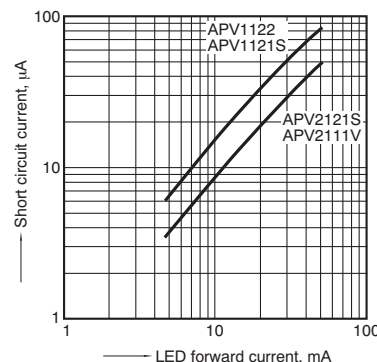

Solid State Relays

SSRs Technical Information

SSR Description and Circuit Configurations

Phototriac coupler

Load	Isolation type	Zero-crossing function	Model	Circuit configuration	I/O wave form (for resistive load)
AC	Phototriac	Yes	APT		
		No	APT		

SSR

Load	Isolation type	Zero-crossing function	Model	Circuit configuration	I/O wave form (for resistive load)
AC	Phototransistor	Yes	AQ1 (2A, 5A) AQ-F		
			Phototriac	Yes	AQ-G AQ1 (3A, 10A) AQ-8 AQ-C
	AQ-J AQ-A AQ-K				
	No	AQ-H			
	No	AQ-G (AQ1)* AQ8 (AQ-J)* AQ-A AQ-C			
		AQ-H			

* AQ1, AQ-J and AQ-A random types are available by special order.

SSR (continued)

Load	Isolation type	Zero-crossing function	Model	Circuit configuration	I/O wave form (for resistive load)
DC	Phototransistor	—	AQ1 AQ-F AQ-C		
DC logic output	Phototransistor	—	AQ-C (IAC)		
		—	AQ-C (IDC)		

Solid State

I/O relays

Load	Isolation type	Zero-crossing function	Model	Circuit configuration	I/O wave form (for resistive load)
AC	Phototransistor	Yes	OAC		
DC		—	ODC		
DC logic output		—	IAC		
	—	IDC			

Principle of Operation

SSR Switching Characteristics

1. SSR for AC Loads

(1) Zero-crossing SSR

The zero-crossing SSR uses a phototransistor or phototriac coupler to isolate the input from the output (see the circuit configuration on the previous page). When the input signal is activated, the internal zero-crossing detector circuit triggers the triac to turn on as the AC load voltage crosses zero.

The load current is maintained by the triac's latching effect after the input signal is deactivated, until the triac is turned off when the load voltage crosses zero. The following describes voltage and current wave forms for different types of loads:

• Resistive loads

Since resistive loads cause no phase shift between the voltage and current, the triac turns on when the AC load voltage crosses zero after the input signal is activated. The SSR turns off when the AC load voltage crosses zero and the load current is turned off after the input signal is subsequently deactivated.

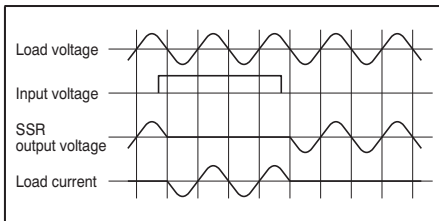

• Inductive loads

The SSR turns on when the load voltage crosses zero after the input signal is activated. It turns off when the load current subsequently crosses zero after the input signal is deactivated. A phase difference between the voltage and current may supply a transient spike to the SSR when it is turned off. While the snubber circuit absorbs this spike, an excessively large spike may result in a dv/dt error in the SSR's internal triac.

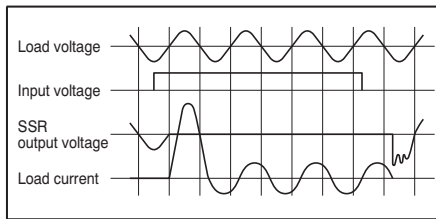

(2) Random type SSR

Random type SSR uses a phototriac coupler to isolate the input from the output. When the input signal is activated, the output immediately turns on, since there is no zero-crossing detector circuit. The load current is maintained by the triac's latching effect after the input signal is deactivated, until the AC load voltage crosses zero.

• Resistive loads

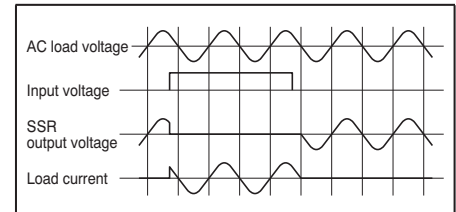

2. SSR for DC Loads

The SSR for DC loads uses a phototransistor coupler to isolate the input from the output. The output immediately responds to the input, since the phototransistor coupler directly turns the output transistor ON or OFF.

3. I/O Relays

(1) Input modules (Types IAC and IDC) Interface SSRs have an input which is completely isolated from the output with a phototransistor coupler. This type of SSR outputs a logic signal that corresponds to the input signal. Two basic types are available: an IAC with an AC input, and an IDC with a DC input.

(2) Output modules (Types OAC and ODC)

The OAC type output module employs a circuit configuration identical to that of the zero-crossing SSR for AC loads; the ODC type output module employs a circuit configuration identical to that of the SSR for DC loads.

Terminology of Phototriac Coupler/AQ-H

	Term	Symbol	Description
Input side	LED forward current	I_F	Current that flows between the input terminals when the input diode is forward biased.
	LED reverse voltage	V_R	Reverse breakdown voltage between the input terminals.
	Peak forward current	I_{FP}	Maximum instantaneous value of the forward current.
	LED dropout voltage	V_F	Dropout voltage between the input terminals due to forward current.
Output side	Repetitive peak OFF-state voltage	V_{DRM}	Maximum voltage with repeatability that can be applied continuously between the output terminals.
	ON-state RMS current	$I_{T(RSM)}$	Effective current value, based on designated conditions, that can flow continuously between output terminals.
	Non-repetitive surge current	I_{TSM}	Maximum current, without repeatability, that is based on designated conditions. Normally this is expressed as the wave height value of one power frequency current sinusoidal cycle.
	Peak ON-state voltage	V_{TM}	Effective value of the voltage drop when a regulated load current flows between the output terminals when device is on.
	Peak OFF-state current	I_{DRM}	Current that flows to output when a regulated load voltage is applied between the output terminals when device is off.
Electrical Characteristics	Trigger LED current	I_{FT}	Current flow when LED current is augmented and output is on, when regulated power supply voltage and load has been connected between the output terminals.
	Holding current	I_H	Load current to maintain on state after output terminals have been turned on based on designated conditions.
	Critical rate of rise of OFF-state voltage	dv/dt	Output terminals do not go to the on state from the off state based on designated conditions.
	Zero-cross voltage	V_{ZC}	In the zero-cross method, when input is turned on, the maximum voltage value when the output terminals turn on.
	Turn on time	T_{on}	Delay time until the output switches on after a designated LED current is made to flow through the input terminals.
	I/O capacitance	C_{iso}	Capacitance between the input and output terminals.
	I/O isolation resistance	R_{iso}	Resistance between terminals (input and output) when a specified voltage is applied between the input and output terminals.

Terminology of SSR

	Term	Description
Input side	Control voltage	Input voltage necessary for normal SSR operation under the specified temperature conditions.
	Activation voltage	Threshold at which the output turns on as the control voltage is gradually increased with the specified voltage applied to the loaded output.
	Recovery voltage	Threshold at which the output turns off as the control voltage is gradually decreased with the specified voltage applied to the loaded output.
	Input impedance	Resistance of the current limiting resistor used in the SSR input side.
	Input line voltage	Input voltage at which an input module SSR operates normally.
	Input current	Input current at which an input module SSR operates normally.
Load side	Max. load current	Maximum continuous current allowable across the SSR output terminals under the specified heat dissipation and ambient temperature conditions. AC current is specified in RMS units.
	Load voltage	Output supply voltage range in which the SSR operates normally. AC voltage is specified in RMS units.
	Logic supply voltage/current	Supply voltage/current range in which an input module SSR operates normally.
	Non-repetitive surge current	Maximum non-repetitive load current allowable under the specified heat dissipation and ambient temperature conditions. In general, it is given by the peak value of a single cycle of sinusoidal commercial AC current.
	"OFF-state" leakage current	Current that flows in the SSR output circuit when the specified supply voltage is applied to the output with no control voltage applied to the input.
	"ON-state" voltage drop	Output voltage drop caused by a specified load current supplied to the SSR output which is turned on by a specified input control voltage. AC voltage is specified in RMS units.
	Min. load current	Minimum load current at and above which the SSR operates normally under the specified temperature conditions. AC load current is specified in RMS units.
	Output stage breakdown voltage	Maximum voltage that can be applied across the output and ground of an input module SSR.
	Max. load current	Maximum current allowable for the output circuit of an input module SSR.
	Repetitive peak voltage, max.	Maximum repetitive voltage which can be continuously applied across the SSR output terminals. In general, a voltage of more than 400 V AC is used for 100 V AC applications, and more than 600 V AC for 200-250 V AC applications, to absorb supply voltage variations or on/off surges.
Critical turn-off voltage rise ratio	SSRs may turn on if a turn-off voltage with a steep rising edge is applied. This phenomenon is called "dv/dt turn on." Critical turn-off voltage rise ratio refers to the maximum turn-off voltage rise ratio at and below which the SSR remains turned off.	
Electrical Characteristics	Operate time, max.	Time until the SSR output turns on after the specified control voltage is applied to the input.
	Release time, max.	Time until the SSR output turns off after the specified control voltage is removed from the input.
	Insulation resistance	Resistance measured with a specified voltage applied across the input and output, or across the input or output and frame ground.
	Breakdown voltage	Maximum voltage below which no dielectric breakdown occurs when applied for 1 minute across the same test points as those used for insulation resistance testing.
	Vibration resistance	Functional: The device sustains no damage and meets the specifications if it is exposed to vibration with its magnitude not exceeding this threshold during transit or installation. Destructive: Closed contacts of a relay remain closed for the specified time period if it is exposed to vibration with its magnitude not exceeding this threshold during operation.
	Shock resistance	Functional: The device sustains no damage and meets the specifications if it is exposed to physical impact with its magnitude not exceeding this threshold during transit or installation. Destructive: Closed contacts of a relay remain closed for the specified time period if it is exposed to physical impact with its magnitude not exceeding this threshold during operation.
	Ambient temperature	Ambient temperature range over which the SSR operates normally under the specified heat dissipation and load current conditions.
	Storage temperature	Ambient temperature range over which an SSR can be safely stored for extended periods without sustaining damage or performance degradation.

Cautions For Use of Phototriac Coupler/AQ-H

SAFETY WARNINGS

- Do not use the product under conditions that exceed the range of its specifications. It may cause overheating, smoke, or fire.
- Do not touch the recharging unit while the power is on. There is a danger of

electrical shock. Be sure to turn off the power when performing mounting, maintenance, or repair operations on the relay (including connecting parts such as the terminal board and socket).

- Check the connection diagrams in the catalog and be sure to connect the terminals correctly. Erroneous connections could lead to unexpected operating errors, overheating, or fire.

Cautions for Use

1. Applying stress that exceeds the absolute maximum rating

If the voltage and current value for any of the terminals exceeds the absolute maximum rating, internal elements will deteriorate because of the excessive voltage and current. In extreme cases, wiring may melt, or silicon P/N junctions may be destroyed.

As a result, the design should ensure that the absolute maximum ratings will never be exceeded, even momentarily.

2. Derating

Derating is absolutely imperative for reliable design and is an essential factor in determining product life. Therefore, be sure to apply derate the maximum rated values when designing a system. Since it is important to derate in accordance with the type of relay, conditions for use, and environment, please be sure to conduct tests using actual equipment. Also, if there is a possibility that, due to a quality problem, this product might have a great effect on human life or property, do take product liability into consideration by being sure to take even extra leeway against the maximum rated value and implement safety measures such as the construction of redundant circuits.

3. The phototriac coupler is designed solely to drive a triac. As a condition, the triac must be powered beforehand.

4. The internal IC could be damaged if a short forms between the I/O terminals while the phototriac coupler and AQ-H SSR are powered.

5. Output spike voltages

1) The figure below shows an ordinary triac drive circuit. Please add a snubber circuit or varistor, as noise/surge on the load side could damage the unit or cause malfunctions.

<Phototriac coupler SOP4, DIP4>

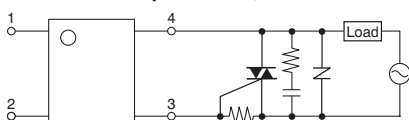

<Phototriac coupler DIP6>

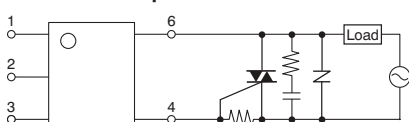

<AQ-H>

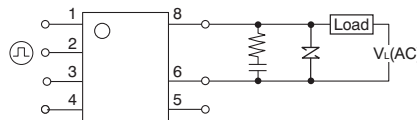

Note: Connection of an external resistor, etc., to terminal No. 5 (gate) is not necessary.

2) Clamp diode can limit spike voltages at the load side. However, long wires may cause spike voltages due to inductance. It is recommended to keep wires as short as possible to minimize inductance.

3) Output terminals may become conductive when a sudden voltage rise is applied, although the input power is not applied. This may occur even if voltage rise between terminals is less than the repetitive peak OFF-state voltage.

Therefore, please perform sufficient tests with actual conditions.

4) When controlling loads using zero-cross voltage types in which the voltage and current phases differ, since the triac sometimes does not turn on regardless of the input state, please conduct sufficient tests using actual equipment.

6. Recommended input current value

$I_F = 20 \text{ mA}$

7. Important Notes for Mounting

1) Temperature rise in the lead portion is highly dependent on package size. If multiple different packages are mounted on the same board, please check your board beforehand in an actual product, ensuring that the temperature conditions of the phototriac coupler fall within the parameters listed.

2) If the mounting conditions exceed the conditions recommended above, strength of the resin used will decrease and inconsistencies of the thermal expansion coefficients in the component materials will increase greatly. This can cause package cracking and breakage of the bonding wires. Please contact us for consultation.

8. Cleaning

The phototriac coupler and AQ-H SSR are formed an optical path by coupling a light-emitting diode (LED) and photodiode via transparent silicon resin. For this reason, unlike other directory element molded resin products (e.g.,

MOS transistors and bipolar transistors), avoid ultrasonic cleaning if at all possible. We recommend cleaning with an organic solvent. If you cannot avoid using ultrasonic cleaning, please ensure that the following conditions are met, and check beforehand for defects.

- Frequency: 27 to 29 kHz
- Ultrasonic output:
 - No greater than 0.25 W/cm^2
- Cleaning time:
 - No longer than 30 s
- Cleanser used: Asahiklin AK-225
- Other: Submerge in solvent in order to prevent the PCB and elements from being contacted directly by the ultrasonic vibrations.

Note: Applies to unit area ultrasonic output for ultrasonic baths.

9. Transportation and storage

1) Extreme vibration during transport will warp the lead or damage the relay. Handle the outer and inner boxes with care.

2) Storage under extreme conditions will cause soldering degradation, external appearance defects, and deterioration of the performance. The following storage conditions are recommended:

- Temperature: 0 to 45°C 32 to 113°F
- Humidity: Less than 70% R.H.
- Atmosphere: No harmful gases such as sulfuric acid gas, minimal dust.

3) Storage of SOP type
Phototriac couplers implemented in SO packages (SOP 4-pin type) are sensitive to moisture and come in sealed moisture-proof packages. Observe the following cautions on storage.

- After the moisture-proof package is unsealed, use the devices as soon as possible (use within 1 month $\leq 45^\circ\text{C}$ 113°F/70% R.H.).
- If the devices are to be left in storage after the moisture-proof package has been unsealed, keep them in another moisture-proof bag containing silica gel and use within 3 months.

10. Soldering

1) When soldering PC board terminals, keep soldering time to within 10 s at 260°C 500°F.

2) When soldering surface-mount terminals or SO package, the following conditions are recommended.

(1) IR (Infrared reflow) soldering method

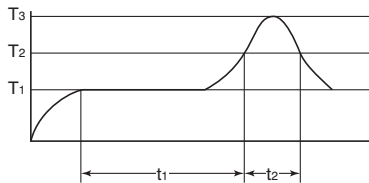

T₁ = 150 to 180°C 302 to 356°F
 T₂ = 230°C 446°F
 T₃ = 250°C 482°F or less
 t₁ = 60 to 120 s or less
 t₂ = 30 s or less

(2) Soldering iron method

Tip temperature: 350 to 400°C 662 to 752°F

Wattage: 30 to 60 W

Soldering time: within 3 s

(3) Others

Check mounting conditions before using other soldering methods (DWS, VPS, hot-air, hot plate, laser, pulse heater, etc.)

• The temperature profile indicates the temperature of the soldered terminal on the surface of the PC board. The ambient temperature may increase excessively. Check the temperature under mounting conditions.

• When using lead-free solder we recommend one with an alloy composition of Sn3.0Ag0.5Cu. Please consult us regarding details such as soldering conditions.

11. The following shows the packaging format

1) Tape and reel (Phototriac coupler)

mm inch

Type	Tape dimensions	Dimensions of paper tape reel
SO package 4-pin type	<p>Tractor feed holes: 0.3±0.05, 1.55±0.05 dia., 1.55±0.05 dia. Direction of picking: 7.2±0.1, 1.75±0.1, 5.5±0.1, 4.7±0.1, 12±0.3, 1.55±0.1 dia. Device mounted on tape: 2.8±0.3, 4±0.1, 1.55±0.1 dia. Dimensions: 12±0.1, 2±0.1, 12±0.1, 2±0.1, 1.55±0.1 dia.</p> <p>(1) When picked from 1/2-pin side: Part No. APT○○○○SX (Shown above) (2) When picked from 3/4-pin side: Part No. APT○○○○SZ</p>	<p>21±0.8, 80±1 dia., 13±0.5 dia., 2±0.5, 14±1.5, 250±2 dia., 80±1 dia., 3.150±.039 dia., 9.843±.079 dia., 3.150±.039 dia., 13±0.5 dia., 5.12±.020 dia., 14±1.5, 2±0.5, .551±.059</p>
DIP 4-pin type	<p>Tractor feed holes: 0.3±0.05, 1.5±1 dia., 1.5±1 dia. Direction of picking: 4±0.1, 1.75±0.1, 10.2±0.1, 5.5±0.1, 3.2±0.1, 12±0.3, 1.55±0.1 dia. Device mounted on tape: 4.2±0.3, 12±0.1, 2±0.1, 1.55±0.1 dia.</p> <p>(1) When picked from 1/2-pin side: Part No. APT○○○○AX (2) When picked from 3/4-pin side: Part No. APT○○○○AZ</p>	<p>21±0.8, 80±1 dia., 13±0.5 dia., 2±0.5, 17.5±2.0, 300±2 dia., 80±1 dia., 3.150±.039 dia., 11.811±.079 dia., 3.150±.039 dia., 13±0.5 dia., 5.12±.020 dia., 17.5±2.0, 2±0.5, .689±.079</p>
DIP 6-pin type	<p>Tractor feed holes: 0.3±0.05, 1.5±1 dia., 1.5±1 dia. Direction of picking: 10.1±0.1, 1.75±0.1, 7.5±0.1, 9.2±0.1, 16±0.3, 1.6±0.1 dia. Device mounted on tape: 4.5±0.3, 12±0.1, 4±0.1, 1.6±0.1 dia.</p> <p>(1) When picked from 1/2/3-pin side: Part No. APT○○○○AX (2) When picked from 4/5/6-pin side: Part No. APT○○○○AZ</p>	<p>21±0.8, 80±1 dia., 13±0.5 dia., 2±0.5, 17.5±2.0, 300±2 dia., 80±1 dia., 3.150±.039 dia., 11.811±.079 dia., 3.150±.039 dia., 13±0.5 dia., 5.12±.020 dia., 17.5±2.0, 2±0.5, .689±.079</p>

		mm inch	
Type	Tape dimensions	Dimensions of paper tape reel	
DIP 4-pin wide terminal type	<p>Tractor feed holes: 1.5^{+0.1} dia., .059^{+0.004} dia.</p> <p>Direction of picking: 4.0^{+0.1}, 5.25^{+0.1}, 1.75^{+0.1}</p> <p>Dimensions: 0.35^{+0.05}, .014^{+0.002}, 3.7^{+0.3}, .146^{+0.012}, 12.0^{+0.1}, .472^{+0.004}, 2.0^{+0.1}, .079^{+0.004}, 1.6^{+0.1} dia., .063^{+0.004} dia., 11.5^{+0.1}, .453^{+0.004}, 24.0^{+0.3}, .945^{+0.012}, 12.1^{+0.1}, .476^{+0.004}</p> <p>(1) When picked from 1/4-pin side: Part No. APT○○○○WAY (2) When picked from 2/3-pin side: Part No. APT○○○○WAW</p>	<p>Reel diameter: 21.0^{+0.8}, .827^{+0.031}</p> <p>Hole diameter: 100⁺¹ dia., 3.937^{+0.039} dia.</p> <p>Reel width: 100⁺¹ dia., 3.937^{+0.039} dia., 330⁺², 12.992^{+0.079}</p> <p>Other dimensions: 2.0^{+0.5}, .079^{+0.020}, 13^{+0.5} dia., .512^{+0.020} dia., 25.5^{+2.0}, 1.004^{+0.079}, 1.7^{+0.8}, .067^{+0.031}</p>	
DIP 6-pin wide terminal type	<p>Tractor feed holes: 1.5^{+0.1} dia., .059^{+0.004} dia.</p> <p>Direction of picking: 4.0^{+0.1}, 9.2^{+0.1}, 1.75^{+0.1}</p> <p>Dimensions: 0.35^{+0.05}, .014^{+0.002}, 4.3^{+0.3}, .169^{+0.012}, 12.0^{+0.1}, .472^{+0.004}, 2.0^{+0.1}, .079^{+0.004}, 1.6^{+0.1} dia., .063^{+0.004} dia., 11.5^{+0.1}, .453^{+0.004}, 24.0^{+0.3}, .945^{+0.012}, 12.1^{+0.1}, .476^{+0.004}</p> <p>(1) When picked from 1/6-pin side: Part No. APT○○○○WAY (2) When picked from 3/4-pin side: Part No. APT○○○○WAW</p>	<p>Reel diameter: 21.0^{+0.8}, .827^{+0.031}</p> <p>Hole diameter: 100⁺¹ dia., 3.937^{+0.039} dia.</p> <p>Reel width: 100⁺¹ dia., 3.937^{+0.039} dia., 330⁺², 12.992^{+0.079}</p> <p>Other dimensions: 2.0^{+0.5}, .079^{+0.020}, 13^{+0.5} dia., .512^{+0.020} dia., 25.5^{+2.0}, 1.004^{+0.079}, 1.7^{+0.8}, .067^{+0.031}</p>	

2) Tape and reel (AQ-H)

		mm inch	
Type	Tape dimensions	Dimensions of paper tape reel	
8-pin SMD type	<p>Tractor feed holes: 1.5^{+0.1} dia., .059^{+0.004} dia.</p> <p>Direction of picking: 4^{+0.1}, 10.1^{+0.1}, 1.75^{+0.1}</p> <p>Dimensions: 0.3^{+0.05}, .012^{+0.002}, 4.5^{+0.3}, .177^{+0.012}, 12.0^{+0.1}, .472^{+0.004}, 2^{+0.1}, .079^{+0.004}, 1.55^{+0.1} dia., .061^{+0.004} dia., 7.5^{+0.1}, .295^{+0.004}, 10.2^{+0.1}, .402^{+0.004}, 16^{+0.3}, .630^{+0.012}</p> <p>(1) When picked from 1/2/3/4-pin side: Part No. AQH○○○○AX (Shown above) (2) When picked from 5/6/8-pin side: Part No. AQH○○○○AZ</p>	<p>Reel diameter: 21^{+0.8}, .827^{+0.031}</p> <p>Hole diameter: 80⁺¹ dia., 3.150^{+0.039} dia.</p> <p>Reel width: 300⁺² dia., 11.811^{+0.079} dia., 80⁺¹ dia., 3.150^{+0.039} dia.</p> <p>Other dimensions: 2^{+0.5}, .079^{+0.020}, 13^{+0.5} dia., .512^{+0.020} dia., 17.5^{+2.0}, .689^{+0.079}, 2^{+0.5}, .079^{+0.020}</p>	

3) Tube

(1) Devices are packaged in a tube as pin No. 1 is on the stopper B side. Observe correct orientation when mounting them on PC boards.

(SOP type)

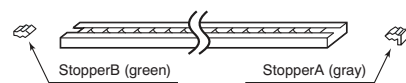

(DIP type)

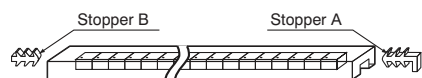

13. Applying stress that exceeds the absolute maximum rating

If the voltage and current value for any of the terminals exceeds the absolute maximum rating, internal elements will deteriorate because of the excessive voltage and current. In extreme cases, wiring may melt, or silicon P/N junctions may be destroyed.

As a result, the design should ensure that the absolute maximum ratings will never be exceeded, even momentarily.

Cautions for Use of SSR

SAFETY WARNINGS

• Do not use the product under conditions that exceed the range of its specifications. It may cause overheating, smoke, or fire.

• Do not touch the recharging unit while the power is on. There is a danger of electrical shock. Be sure to turn off the power when performing mounting, maintenance, or repair operations on the relay (including connecting parts such as the terminal board and socket).

• Check the connection diagrams in the catalog and be sure to connect the terminals correctly. Erroneous connections could lead to unexpected operating errors, overheating, or fire.

Cautions for Use

1. Regarding output noise surge protection

(1) AC Output Type

A high noise surge voltage applied to the SSR load circuit can cause malfunction or permanent damage to the device. If such a high surge is anticipated, use a varistor across the SSR output.

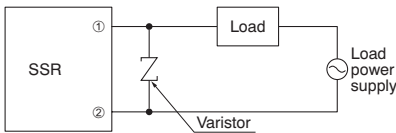

Note: AQ-F solid-state relay output terminals are numbered (8) and (12).

(2) DC Output Type

When the SSR is loaded with an inductive load, such as a solenoid contactor, motor, or solenoid valve, use a counter-EMF suppression diode across the load.

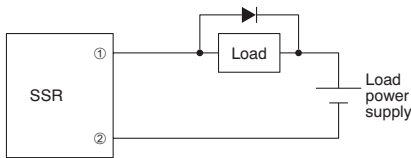

2. When used for the load less than rated

An SSR may malfunction if it is used below the specified load. In such an event, use a dummy resistor in parallel with the load.

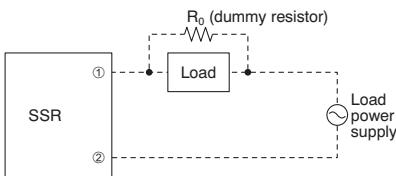

Load Specifications

Type	Load current
AQ-G All models	20 mA
AQ-1 AC output type DC output type	50 mA 5 mA
AQ-8 100 V type 200V type	25 mA 50 mA
AQ-F AC output type DC output type	50 mA 5 mA
AQ-J All models	50 mA

Type	Load current
AQ-A All models	100 mA
AQ-K All models	100 mA
AQ-C 100 V type with AC output 200 V type with AC output DC output type	10 mA 20 mA 1 mA
I/O AC output module DC output module	50 mA 5 mA

3. Noise and surge protection at the input side

A high noise surge voltage applied to the SSR input circuit can cause malfunction or permanent damage to the device. If such a high surge is anticipated, use C or R noise absorber in the input circuit.

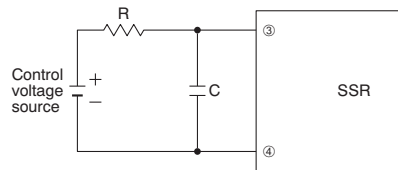

4. When the input terminals are connected with reverse polarity

Type	If the polarity of the input control voltage is reversed
AQ1, AQ-F, AQ-J, AQ-A, AQ-K AQ-J I/O relay	Reversing the polarity will not cause damage to the device, due to the presence of a protection diode, but the device will not operate.
AQ-H, AQ-G, AQ8, AQ-C	Reversing the polarity may cause permanent damage to the device. Take special care to avoid polarity reversal or use a protection diode in the input circuit.

5. In the case of operating voltage containing ripple

If the SSR control voltage contains ripple, the peak of the ripple should not exceed the maximum rated control voltage, and the bottom of the ripple should exceed the minimum rated control voltage.

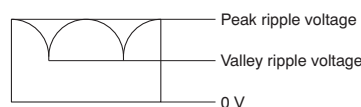

6. Cleaning solvents compatibility

Dip cleaning with an organic solvent is recommended for removal of solder flux, dust, etc. If ultrasonic cleaning must be used, the severity of factors such as frequency, out power and cleaning solvent selected may cause loose wires and other troubles.

Please make sure these conditions before use.

7. Transportation and storage

1) Extreme vibration during transport will warp the lead or damage the relay. Handle the outer and inner boxes with care.

2) Storage under extreme conditions will cause soldering degradation, external appearance defects, and deterioration of the characteristics. The following storage conditions are recommended:

- Temperature: 0 to 45°C 32 to 113°F
- Humidity: Less than 70% R.H.
- Atmosphere: No harmful gasses such as sulfurous acid gas, minimal dust.

8. Others

(1) If an SSR is used in close proximity to another SSR or heat-generating device, its ambient temperature may exceed the allowable level. Carefully plan SSR layout and ventilation.

(2) Soldering to SSR terminals should be completed within 5 seconds at 260°C.

(3) Terminal connections should be made by referring to the associated wiring diagram.

(4) For higher reliability, check device quality under actual operating conditions.

Cautions for Use of SSR

Snubber Circuit

1. Reduce dv/dt

An SSR used with an inductive load can accidentally fire due to a high load voltage rise rate (dv/dt), even though the load voltage is below the allowable level (inductive load firing).

Our SSRs contain a snubber circuit designed to reduce dv/dt (except AQ-H).

2) R selection

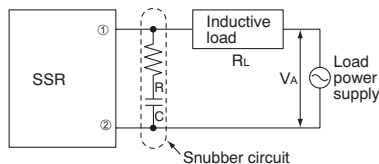

If there is no resistance R (the resistance R controls the discharge current from condenser C), at turn-on of the SSR, there will be a sharp rise in dv/dt and the high peak value discharge current will begin to flow. This may cause damage to the internal elements of the SSR.

2. Selecting the snubber constants

1) C selection

The charging coefficient tau for C of the SSR circuit is shown in formula ①

$$\tau = (R_L + R) \times C \text{ ----- ①}$$

By setting formula ① so that it is below dv/dt value you have:

$$C = 0.632 V_A / ((dv/dt) \times (R_L + R)) \text{ ----- ②}$$

Therefore, it is always necessary to insert a resistance R. In normal applications, for the 100 V line, have R = 10 to 100 Ω and for the 200 V line, have R = 20 to 100 Ω. (The allowable discharge current at turn-on will differ depending on the internal elements of the SSR.) The power loss from R, written as P, caused by the discharge current and charging current from C, is shown in formula ③ below. For the 100 V line, use a power of 1/2 W, and for the 200 V line, use a power above 2 W.

$$P = \frac{C \times V_A^2 \times f}{2} \text{ ----- ③}$$

f = Power supply frequency

By setting C = 0.1 to 0.2 μF, dv/dt can be controlled to between nV/μs and n+V/μs or lower. For the condenser, use either an MP condenser metallized polyester film. For the 100 V line, use a voltage between 250 and 400 V, and for the 200 V line, use a voltage between 400 and 600 V.

Also, at turn-off of the SSR, a ringing circuit is formed with the capacitor C and the circuit inductance L, and a spike voltage is generated at both terminals of the SSR. The resistance R serves as a control resistance to prevent this ringing. Moreover, a good non-inductive resistance for R is required. Carbon film resistors or metal film resistors are often used. For general applications, the recommended values are C = 0.1 μF and R = 20 to 100 Ω. There are cases of resonance in the inductive load, so the appropriate care must be taken when making your selections.

Thermal Design

SSRs used in high-reliability equipment require careful thermal design. In particular, junction temperature control has a significant effect on device function and life time. The rated load current for board-mounting SSRs is defined as the maximum current allowable at an ambient temperature of 40°C (30°C) and under natural cooling. If the ambient temperature exceeds the SSRs derating temperature point (20°C to 40°C, depending on SSR), load current derating in accordance with the load current vs temperature diagram becomes necessary. If adjacent devices act as heat sources, the SSR should be located more than 10 mm away from those devices. SSRs with a 5 A rating or more must be used with the dedicated heat sinks listed in Table 1 or equivalents. To ensure

adequate thermal conduction, apply thermal conductive compound (Toshiba silicone YG6111, TSK5303 or alternate) to the SSR's mounting surface. For

information on external heat sinks for our SSRs and their mounting method, refer to "Data and Cautions for Use for respective relay".

Table 1. Dedicated on-board heat sinks

Load current	Type	Heat sink
to 10 A	AQ10A2-ZT4/32V DC	AQ-HS-5A
10 A	AQ-J (10A)	AQP-HS-J10A AQP-HS-J10A (for AQ-J) AQP-HS-SJ10A (for AQ-J)* AQP-HS-SJ20A*
15 A	AQ-A (15A), AQ-J (15A)	AQP-HS-J10A AQP-HS-J10A (for AQ-J) AQP-HS-SJ10A (for AQ-J)* AQP-HS-SJ20A*
20 A	AQ-J (25A)	AQP-HS-J10A AQP-HS-SJ10A (for AQ-J)* AQP-HS-SJ20A*
25 to 40 A	AQ-A (25A)	AQP-HS-30/40A
25 A	AQ-J (25A)	AQP-HS-J25A
40 A	AQ-A (40A)	AQP-HS-J25A

*It is possible to mounting on the DIN rail.

Protection Circuit

High-reliability SSR circuits require an adequate protection circuit, as well as careful study of the characteristics and maximum ratings of the device.

1. Over-Voltage Protection

The SSR load power supply requires adequate protection against over-voltage errors from various causes. The methods of over-voltage protection include the following:

(1) Use devices with a guaranteed reverse surge withstand voltage (controlled avalanche devices, etc.)

(2) Suppress transient spikes

Use a switching device in the secondary circuit of a transformer or use a switch with a slow opening speed.

(3) Use a surge absorption circuit

Use a CR surge absorber or varistor across the load power supply or SSR. Special care must be taken so power on/off surges or external surges do not exceed the device's rated load voltage. If a surge voltage exceeding the device's rated voltage is anticipated, use a surge absorption device and circuit (e.g. a ZNR from Panasonic Electronic Devices Co., Ltd.).

Cautions for Use of SSR

Choosing the Rated Voltage of the ZNR

- (1) Peak supply voltage
- (2) Supply voltage variation
- (3) Degradation of ZNR characteristic (1 mA±10%)

- (4) Tolerance of rated voltage (10%)
- For application to 100 V AC lines, choose a ZNR with the following rated voltage:
- $$(1) \times (2) \times (3) \times (4) = (100 \times 2) \times 1.1 \times 1.1 \times 1.1 = 188 \text{ (V)}$$

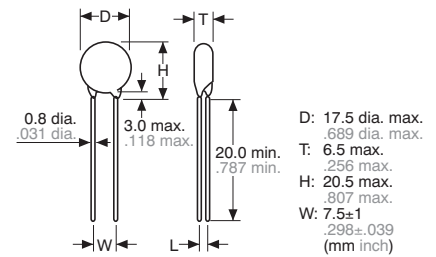

Example of ZNR (Panasonic Electronic Components)

Types	Varistor voltage V1mA (V)	Max. allowable circuit voltage		Max. control voltage V50A (V)	Max. average pulse electric power (W)	Withstanding energy		Withstanding surge current		Electrostatic capacitance (Reference) @1KHz (pF)
		ACrms (V)	DC (V)			(10/1000μs) (J)	(2ms) (J)	1time (A)	(8/20μs) 2time (A)	
ERZV14D201	200 (185 to 225)	130	170	340	0.6	70	50	6,000	5,000	770
ERZV14D221	220 (198 to 242)	140	180	360	0.6	78	55	6,000	5,000	740
ERZV14D241	240 (216 to 264)	150	200	395	0.6	84	60	6,000	5,000	700
ERZV14D271	270 (247 to 303)	175	225	455	0.6	99	70	6,000	5,000	640
ERZV14D361	360 (324 to 396)	230	300	595	0.6	130	90	6,000	4,500	540
ERZV14D391	390 (351 to 429)	250	320	650	0.6	140	100	6,000	4,500	500
ERZV14D431	430 (387 to 473)	275	350	710	0.6	155	110	6,000	4,500	450
ERZV14D471	470 (423 to 517)	300	385	775	0.6	175	125	6,000	4,500	400
ERZV14D621	620 (558 to 682)	385	505	1,025	0.6	190	136	6,000	4,500	330
ERZV14D681	680 (612 to 748)	420	560	1,120	0.6	190	136	5,000	4,500	320

2. Over-Current Protection

An SSR circuit operated without over-current protection may result in damage to the device. Design the circuit so the device's rated junction temperature is not exceeded for a continuous overload current.

(e.g. Surge current into a motor or light bulb)

The surge-on current rating applies to over-current errors which occur less than several tens of times during the service life of a semiconductor device. A protection coordination device is required for this rating.

Methods of over-current protection include the following:

- (1) Suppressing over-currents
Use a current limiting reactor in series with the load power supply.
- (2) Use a current shut-off device
Use a current limiting fuse or circuit breaker in series with the load power supply.

Example of executing fuse selection of over-current protection cooperation

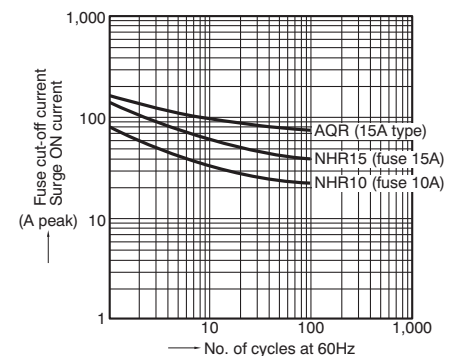

Load Type Description

1. Heaters (Resistive Load)

The SSR is best suited to resistive loads. Noise levels can be drastically lowered with zero-crossing switching.

2. Lamps

Tungsten or halogen lamps draw a high inrush current when turned on (approximately 7 to 8 times the steady-state current for zero-crossing SSRs; approximately 9 to 12 times, in the worst case, for random type SSRs). Choose an SSR so the peak of the inrush current does not exceed 50% of the SSR surge-on current.

3. Solenoids

AC-driven solenoid contactors or solenoid valves also draw inrush current when they are activated. Choose an SSR such that the peak of the inrush current does not exceed 50% of the SSR surge-on current. For small solenoid valves and AC relays in particular, a leakage current may cause the load to malfunction after the SSR turns off. In such an event, use a dummy resistor in parallel with the load.

- Using an SSR below the Specified Load

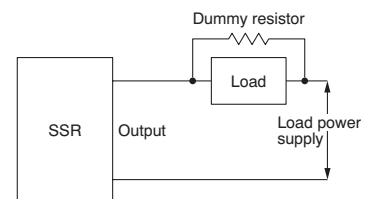

Cautions for Use of SSR

4. Motors

When starting, an electric motor draws a symmetrical AC starting current some 5 to 10 times the steady-state load current, superimposed on a DC current. The starting time during which this high starting current is sustained depends on the capacities of the load and load power supply. Measure the starting current and time under the motor's actual operating conditions and choose an SSR so the peak of the starting current does not exceed 50% of the SSR surge-on current. When the motor load is deactivated, a voltage exceeding the load supply voltage is applied to the SSR due to counter-EMF. This voltage is approximately 1.3 times the load supply voltage for induction motors, and approximately 2 times that for synchronous motors.

• Reversible Motor Control

When the direction of motor rotation is reversed, the transient current and time required for the reversal far exceed those required for simple starting. The reversing current and time should also be measured under actual operating conditions.

For a capacitor-starting, single-phase induction motor, a capacitive discharge current appears during the reversal process. Be sure to use a current limiting resistor or reactor in series with the SSR. Also, the SSR should have a high marginal voltage rating, since a voltage twice as high as the load supply voltage develops across the SSR in the reversal process. (For reversible control on a 100 V AC line, use SSRs with a 200 V rating; for use on a 200 V AC line, contact your nearest our representative for further information.)

For reversible motor control, carefully design the driver circuit so the forward and reverse SSRs do not turn on at the same time.

Transistor-driven reversible motor control circuit

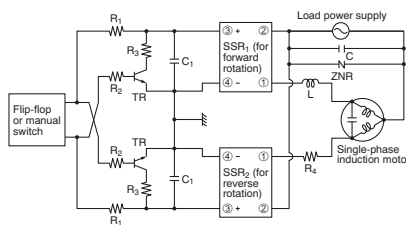

5. Capacitive Load

A capacitive load (switching regulator, etc.) draws an inrush current to charge the load capacitor when the SSR turns on. Choose an SSR so the peak of the inrush current does not exceed 50% of the SSR surge-on current. A timing error of up to one cycle can occur when a switch used in series with the SSR is opened or closed. If this is a problem, use an inductor (200 to 500 μ H) in series to the SSR to suppress dv/dt error.

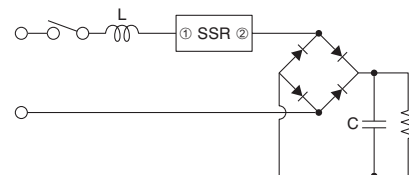

6. Other Electronic Equipment

In general, electronic equipment uses line filters in the primary supply circuit. The capacitors used in the line filters may cause the SSR to malfunction due to dv/dt turn on when the equipment is turned on or off. In such an event, use an inductor (200 to 500 μ H) in series with the SSR to suppress dv/dt turn on.

Load Inrush Current Wave and Time

(1) Incandescent Lamp Load

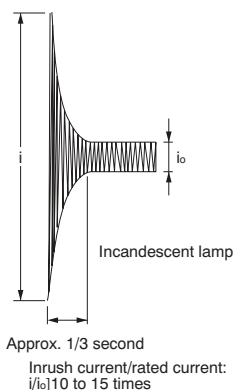

(2) Mercury Lamp Load i/i_o 3 times

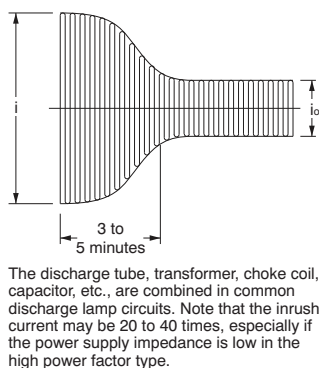

(3) Fluorescent Lamp Load i/i_o 5 to 10 times

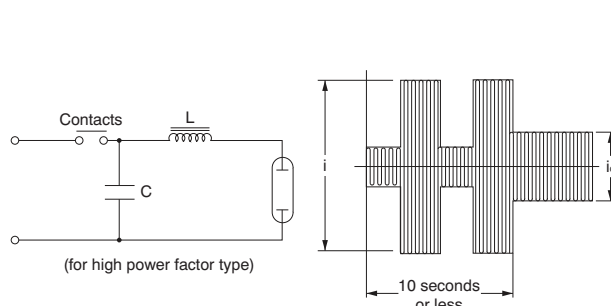

(4) Motor Load i/i_o 5 to 10 times

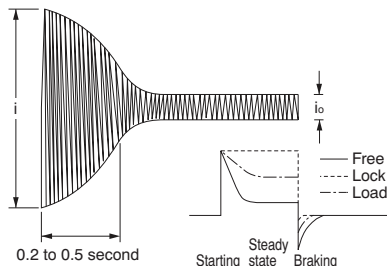

• Conditions become more harsh if plugging or inching is performed since state transitions are repeated.
• When using a relay to control a DC motor and brake, the on time inrush current, steady-state current and off time brake current differ depending on whether the load to the motor is free or locked. In particular, with non-polarized relays, when using from B contact of from contact for the DC motor brake, mechanical life might be affected by the brake current. Therefore, please verify current at the actual load.

(5) Solenoid Load i/i_o 10 to 20 times

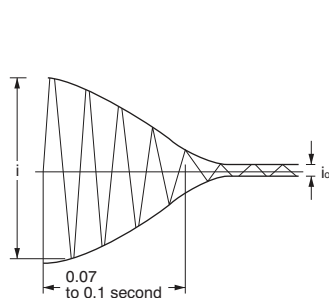

Note that since inductance is great, the arc lasts longer when power is cut. The contact may become easily worn.

(6) Electromagnetic Contact Load i/i_o 3 to 10 times

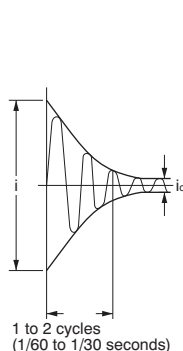

(7) Capacitive Load i/i_o 20 to 40 times

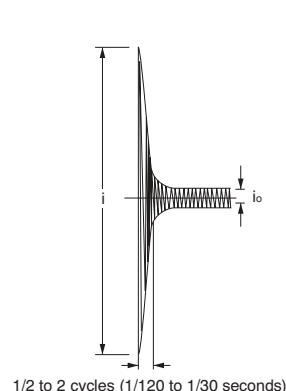

Cautions for Use of SSR

SSR Driving Circuits

1. Relay Driver

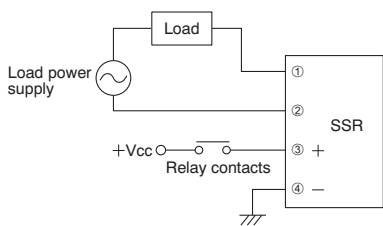

2. NPN Transistor Driver

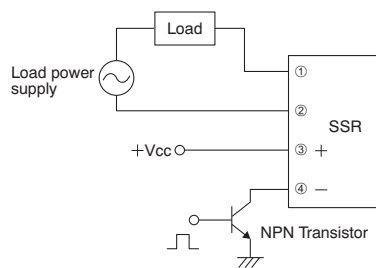

3. PNP Transistor Driver

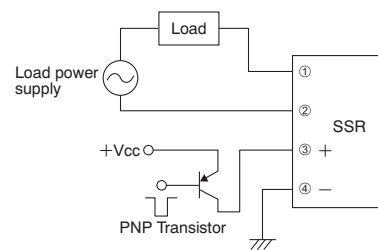

4. TTL/DTL/IC Driver

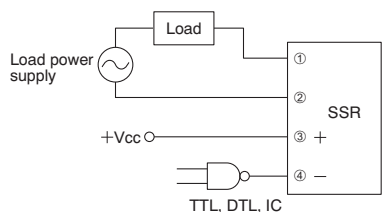

5. C-MOS/IC Driver

(1) SSR fires when IC output is HIGH:

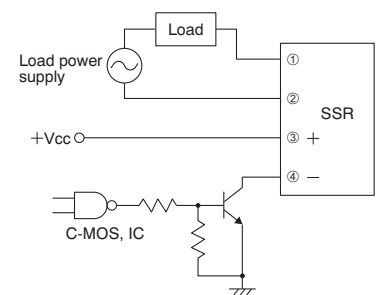

(2) SSR fires when IC output is LOW:

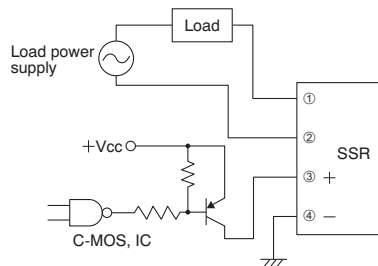

Solid State

6. Self Sustaining Circuit Using SSR

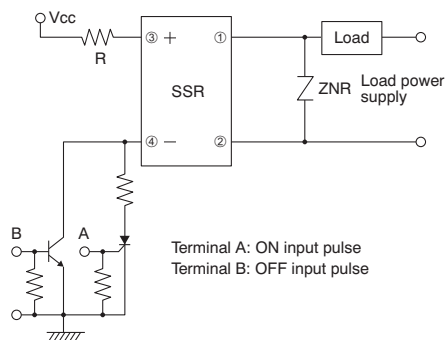

7. Driving with a Shared Supply

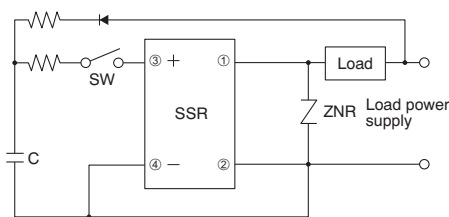

8. SSRs Used in Series

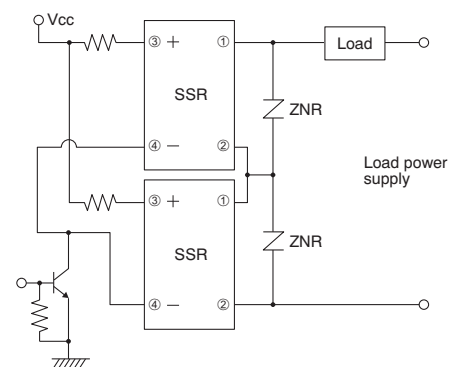

Phototriac Coupler, AQ-H Solid State Relay Driving Circuits

1. NPN Transistor Driver

1) Phototriac Coupler

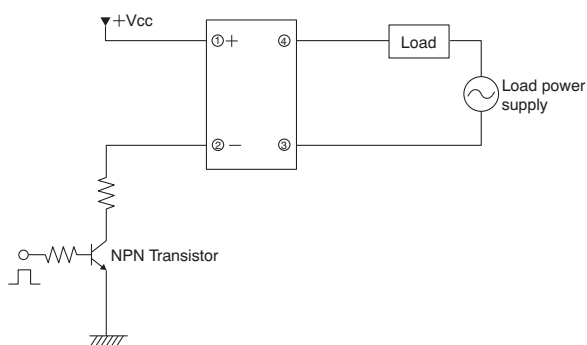

2) AQ-H Solid State Relay

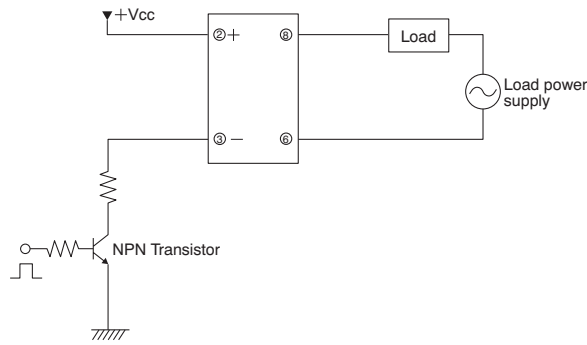

* Phototriac coupler and AQ-H is current driving type.

Phototriac Coupler/AQ-H Application Examples

Phototriac Coupler/AQ-H Application Examples

Typical Applications

1. Temperature control for heater control

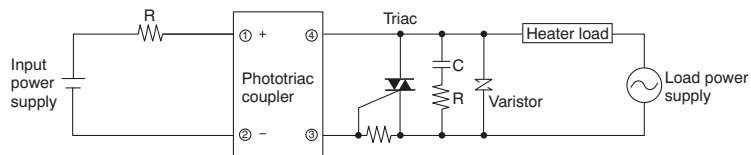

2. Airflow control for fan motors

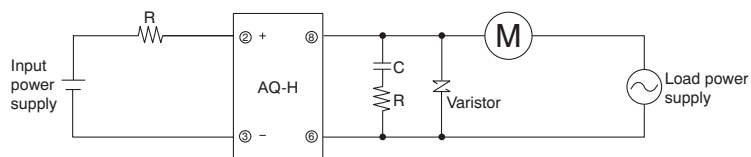

SSR Application Examples

SSR Application Examples

Typical Applications

1. Light Bulb

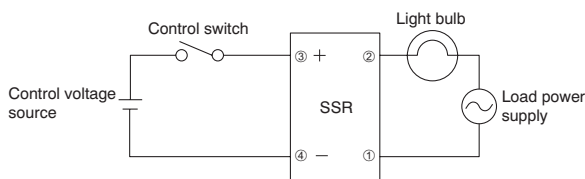

2. Electric Furnace Temperature Control

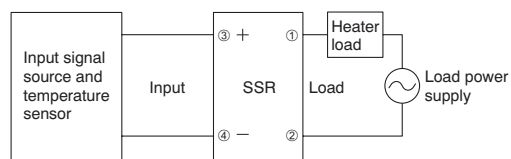

* KT Temperature Controller is available.

3. Single-Phase Induction Motor Control

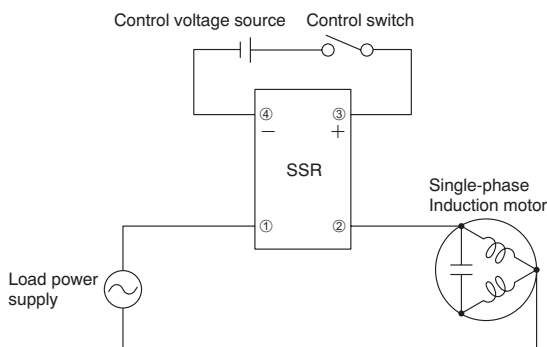

4. Reversible Control for a Single-Phase Induction Motor

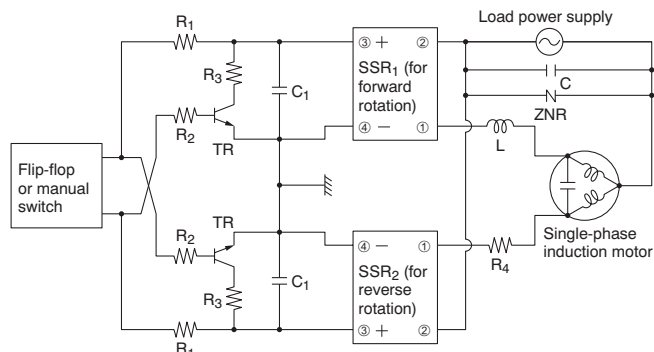

Solid State

5. Three-Phase Induction Motor Control

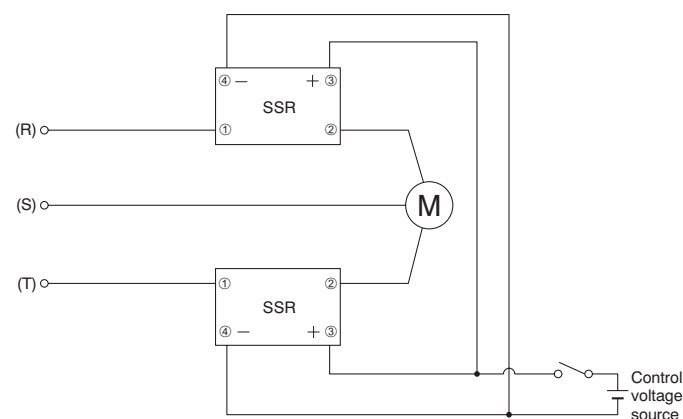

6. Reversible Control for a 3-Phase Induction Motor

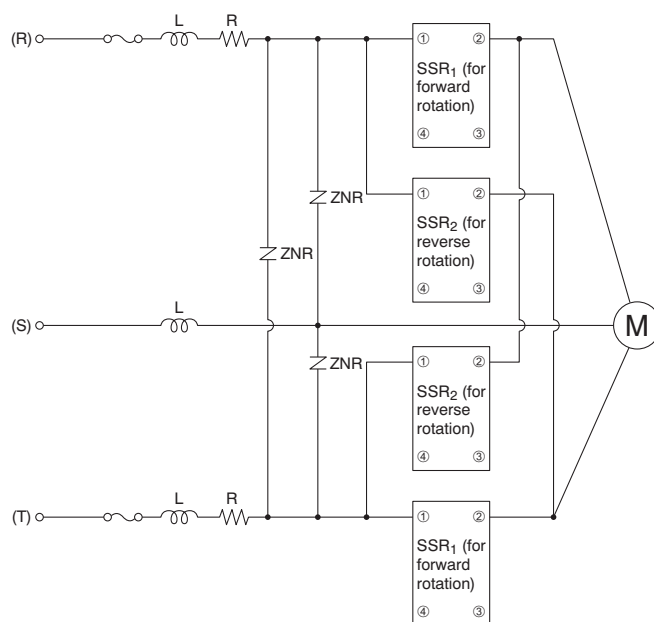

Note: Take special care in the design to ensure that both the forward and reverse SSRs do not turn on at the same time.

Recommended Temperature Controllers



<KT4H Temperature Controller>

Our temperature controller is recommended for use with our Solid State Relays.

Features

- Data can be collected using the RS485 communications interface via a PLC.
- Improved visibility using a negative type LCD and backlight.
- Depth-wise length (chassis dimension) is 56 mm 2.205 inch.

Substitute part numbers

Power supply	Control output	Part No.
100 to 240 V AC	Relay contact	AKT4H111100

*For detailed product information about temperature controllers, please refer to our website:
http://panasonic-denko.co.jp/ac/e/fasys/component/temperature_controller/

SSR Load Recommendation Chart

Please use this chart when selecting the SSR load. The values presented are for ambient temperatures of 40°C 104°F (30°C 86°F) and lower. When selected, please measure the load current waveform and use within the range of each surge current characteristic.

Load voltage	Product	Max. load current	Type of load						Remarks
			Heater	Solenoid bulb	Single-phase motor	Triple-phase motor	Lamp	Transformer	
110 V AC	AQC (Output module) AQQ (1A type)	1A	0.8A	0.5A	7W	—	0.5A	50W	
	AQ8 (2A type) I/O (Output module) AQQ (2A type)	2A	1.6A	1A	15W	—	1A	100W	
	AQF (2A type)	2A	1.6A	1A	30W	—	1A	100W	
	AQF (3A type) AQ8 (3A type) AQ1 (3A type)	3A	2.4A	1.5A	60W	—	1.5A	150W	
	AQ1 (10A type) AQJ (10A type)	10A	8A	5A	200W	—	5A	500W	Heat sink AQP-HS-SJ10A (AQJ type) Heat sink AQP-HS-J10A, AQP-HS-SJ20A Heat sink AQ-HS-5A (AQ1 type)
	AQA (15A type) AQK (15A type) AQJ (15A type)	15A	12A	7.5A	300W	—	7.5A	750W	Heat sink AQP-HS-J10A, AQP-HS-SJ20A Heat sink AQP-HS-J10A (AQ-J type) (except AQ-K type)
	AQK (25A type) AQA (25A type) AQJ (25A type)	25A	20A	12.5A	500W	—	12.5A	1.25kW	Heat sink AQP-HS-30/40A (AQ-A type) Heat sink AQP-HS-J25A (AQ-J type)
	AQA (40A type)	40A	32A	20A	750W	—	20A	2kW	Heat sink AQP-HS-J25A (AQ-A type)
220 V AC	AQC (Output module) AQQ (1A type)	1A	0.8A	0.5A	15W	50W	0.5A	100W	
	AQ8 (2A type) I/O (Output module) AQQ (2A type)	2A	1.6A	1A	35W	100W	1A	200W	
	AQF (2A type)	2A	1.6A	1A	75W	200W	1A	200W	
	AQF (3A type) AQ8 (3A type) AQ1 (3A type)	3A	2.4A	1.5A	100W	300W	1.5A	300W	
	AQ1 (10A type) AQJ (10A type)	10A	8A	5A	400W	1kW	5A	1kW	Heat sink AQP-HS-SJ10A (AQJ type) Heat sink AQP-HS-J10A, AQP-HS-SJ20A Heat sink AQ-HS-5A (AQ1 type)
	AQK (15A type) AQA (15A type) AQJ (15A type)	15A	12A	7.5A	600W	1.5kW	7.5A	1.5kW	Heat sink AQP-HS-J10A, AQP-HS-SJ20A Heat sink AQP-HS-J10A (AQ-J type) (except AQ-K type)
	AQK (25A type) AQA (25A type) AQJ (25A type)	25A	20A	12.5A	1kW	2.5kW	12.5A	2.5kW	Heat sink AQP-HS-30/40A (AQ-A type) Heat sink AQP-HS-J25A (AQ-J type)
	AQA (40A type)	40A	32A	20A	1.5kW	3.7kW	20A	4kW	Heat sink AQP-HS-J25A (AQ-A type)
48 V DC	AQC (Output module)	1A	0.8A	0.5A	—	—	0.5A	—	
	AQ1 (2A type) I/O (Output module) AQF (2A type)	2A	1.6A	1.0A	—	—	1.0A	—	
	AQF (3A type)	3A	2.4A	1.5A	—	—	1.5A	—	
100 V DC	AQ1 (1A type) I/O (Output module)	1A	0.8A	0.5A	—	—	0.5A	—	

Panasonic

ideas for life

Phototriac Coupler with various options for external Triac control

Phototriac Coupler (APT1)

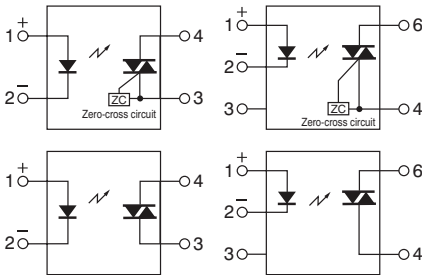
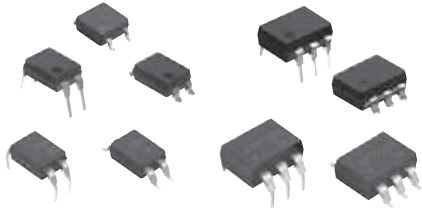

FEATURES

1. Low zero-cross voltage (max. 15 V) type added to lineup. Approximately 1/3 of previous product

Helps reduce device noises even further.

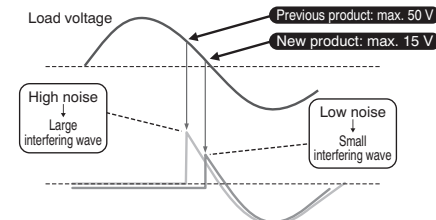

2. Two types available: Random type and zero-cross type

3. Many package sizes available.

(Wide terminal type with 10.16 mm pitch between I/O terminals available.)

4. High dielectric strength. (Between input and output: SOP 3, 750 V; DIP 5,000 V)

5. Handles both 100 and 200 V AC loads

This relay handles both voltages in a single product it is not necessary for users that use both types to manage separate part numbers.

6. Terminal 5 of the DIP 6-pin type is completely molded.

TYPICAL APPLICATIONS

1. For triac driver in heater controls of products such as office equipment, home appliances, and industrial machines. (For 100V/200V, 50/60 Hz lines)

2. Triac driver for SSRs

Solid State

TYPES

1. SOP4 Type

Type	Output rating		Type	Package size	Part No.			Packing quantity	
	Repetitive peak OFF-state voltage	ON-state RMS current			Tube packing style	Tape and reel packing style		Tube	Tape and reel
AC type	600 V	50 mA	Zero-cross (max. 50 V)	SOP4pin	APT1211S	APT1211SX (Picked from the 1/2-pin side)	APT1211SZ (Picked from the 3/4-pin side)	1 tube contains: 100 pcs. 1 batch contains: 2,000 pcs.	1,000 pcs.
			Zero-cross (max. 15 V)		APT1231S	APT1231SX (Picked from the 1/2-pin side)	APT1231SZ (Picked from the 3/4-pin side)		
			Random		APT1221S	APT1221SX (Picked from the 1/2-pin side)	APT1221SZ (Picked from the 3/4-pin side)		

Note: For space reasons, the initial letters of the product number "APT" and "S" are omitted on the product seal.

The package type indicator "X" and "Z" are omitted from the seal. (Ex. the label for product number APT1221SZ is 1221).

Phototriac Coupler (APT1)

2. DIP4/6 Type

Type	Output rating		Type	Package size	Part No.				Packing quantity	
	Repetitive peak OFF-state voltage	ON-state RMS current			Through hole terminal	Surface-mount terminal		Tube	Tape and reel	
					Tube packing style		Tape and reel packing style			
AC type	600 V	100 mA	Zero-cross (max. 50 V)	DIP4pin	APT1211	APT1211A	APT1211AX (Picked from the 1/2-pin side)	APT1211AZ (Picked from the 3/4-pin side)	[DIP4pin] 1 tube contains: 100 pcs. 1 batch contains: 1,000 pcs. [DIP6pin] 1 tube contains: 50 pcs. 1 batch contains: 500 pcs.	[DIP4pin] [DIP6pin] 1,000 pcs.
			Zero-cross (max. 15 V)		APT1231	APT1231A	APT1231AX (Picked from the 1/2-pin side)	APT1231AZ (Picked from the 3/4-pin side)		
			Random		APT1221	APT1221A	APT1221AX (Picked from the 1/2-pin side)	APT1221AZ (Picked from the 3/4-pin side)		
			Zero-cross (max. 50 V)	DIP6pin	APT1212	APT1212A	APT1212AX (Picked from the 1/2/3-pin side)	APT1212AZ (Picked from the 4/6-pin side)		
			Zero-cross (max. 15 V)		APT1232	APT1232A	APT1232AX (Picked from the 1/2/3-pin side)	APT1232AZ (Picked from the 4/6-pin side)		
			Random		APT1222	APT1222A	APT1222AX (Picked from the 1/2/3-pin side)	APT1222AZ (Picked from the 4/6-pin side)		

Note: For space reasons the initial letters "APT" of the product number for the DIP 4-pin type, the letter "A", which indicates the SMD terminal shape for the DIP 4-pin and 6-pin types, and the package type indications "X" and "Z" have been omitted from the product label. (Example: The label for product number APT1221AZ is 1221.)

3. DIP4/6 Wide Terminal Type

Type	Output rating*		Type	Package size	Part No.				Packing quantity	
	Repetitive peak OFF-state voltage	ON-state RMS current			Through hole terminal	Surface-mount terminal		Tube	Tape and reel	
					Tube packing style		Tape and reel packing style			
AC type	600 V	100 mA	Zero-cross (max. 50 V)	DIP4pin	APT1211W	APT1211WA	APT1211WAY (Picked from the 1/4-pin side)	APT1211WAW (Picked from the 2/3-pin side)	[DIP4pin] 1 tube contains: 100 pcs. 1 batch contains: 1,000 pcs. [DIP6pin] 1 tube contains: 50 pcs. 1 batch contains: 500 pcs.	[DIP4pin] [DIP6pin] 1,000 pcs.
			Zero-cross (max. 15 V)		APT1231W	APT1231WA	APT1231WAY (Picked from the 1/4-pin side)	APT1231WAW (Picked from the 2/3-pin side)		
			Random		APT1221W	APT1221WA	APT1221WAY (Picked from the 1/4-pin side)	APT1221WAW (Picked from the 2/3-pin side)		
			Zero-cross (max. 50 V)	DIP6pin	APT1212W	APT1212WA	APT1212WAY (Picked from the 1/6-pin side)	APT1212WAW (Picked from the 3/4-pin side)		
			Zero-cross (max. 15 V)		APT1232W	APT1232WA	APT1232WAY (Picked from the 1/6-pin side)	APT1232WAW (Picked from the 3/4-pin side)		
			Random		APT1222W	APT1222WA	APT1222WAY (Picked from the 1/6-pin side)	APT1222WAW (Picked from the 3/4-pin side)		

Note: For space reasons the initial letters "APT" of the product number for the DIP 4-pin type, the letter "WA", which indicates the SMD terminal shape for the DIP 4-pin and 6-pin types, and the package type indications "Y" and "W" have been omitted from the product label. (Example: The label for product number APT1221WAY is 1221.)

RATING

1. Absolute maximum ratings (Ambient temperature: 25°C 77°F)

1) SOP4 types

Item		Symbol	APT1211S, APT1221S, APT1231S	Remarks
Input	LED forward current	I_F	50 mA	
	LED reverse voltage	V_R	6 V	
	Peak forward current	I_{FP}	1 A	f = 100 Hz, Duty Ratio = 0.1%
Output	Repetitive peak OFF-state voltage	V_{DRM}	600 V	
	ON-state RMS current*	$I_{T(RMS)}$	0.05 A	AC
	Non-repetitive surge current	I_{TSM}	0.6 A	In one cycle at 60Hz
Total power dissipation		P_T	350 mW	
I/O isolation voltage		V_{ISO}	3,750 V AC	
Temperature limits	Operating	T_{opr}	-40°C to +100°C -40°F to +212°F	Non-condensing at low temperatures
	Storage	T_{stg}	-40°C to +125°C -40°F to +257°F	

Note: "X" and "Z" at the end of the part numbers have been omitted.

Phototriac Coupler (APT1)

2) DIP4/6 type and DIP4/6 Wide terminal type

Item		Symbol	APT1211(W)	APT1221(W)	APT1231(W)	APT1212(W)	APT1222(W)	APT1232(W)	Remarks
Input	LED forward current	I_F	50 mA						
	LED reverse voltage	V_R	6 V						
	Peak forward current	I_{FP}	1 A						$f = 100 \text{ Hz}$, Duty Ratio = 0.1%
Output	Repetitive peak OFF-state voltage	V_{DRM}	600 V						
	ON-state RMS current*	$I_{T(RMS)}$	0.1 A						AC
	Non-repetitive surge current	I_{TSM}	1.2 A						In one cycle at 60Hz
Total power dissipation		P_T	500 mW						
I/O isolation voltage		V_{iso}	5,000 V AC						
Temperature limits	Operating	T_{opr}	-40°C to $+100^\circ\text{C}$ -40°F to $+212^\circ\text{F}$						Non-condensing at low temperatures
	Storage	T_{stg}	-40°C to $+125^\circ\text{C}$ -40°F to $+257^\circ\text{F}$						

Note: "A", "AX", "AZ" "AY" and "AW" at the end of the part numbers have been omitted.

* Do not exceed 0.05 A of ON state RMS current in case of following load voltage condition.

DIP4pin (APT1211, APT1221, APT1231) and DIP4pin wide terminal type (APT1211W, APT1221W, APT1231W): more than 100 V AC;

DIP6pin (APT1212, APT1222, APT1232) and DIP6pin wide terminal type (APT1212W, APT1222W, APT1232W): more than 120 V AC.

2. Electrical characteristics (Ambient temperature: 25°C 77°F)

1) Zero-cross voltage type (max. 50V) and random type

Item		Symbol	APT1211S, APT1211(W), APT1212(W)	APT1221S, APT1221(W), APT1222(W)	Condition	
Input	LED dropout voltage	Typical	1.21 V		$I_F = 20 \text{ mA}$	
		Maximum	1.3 V			
	LED reverse current	Typical	—		$V_R = 6 \text{ V}$	
Maximum		10 μA				
Output	Repetitive peak OFF-state current	Typical	—		$I_F = 0 \text{ mA}$ $V_{DRM} = 600 \text{ V}$	
		Maximum	1 μA			
	Repetitive peak On-state voltage	Typical	1.3 V		$I_F = 10 \text{ mA}$ $I_{TM} = 0.05 \text{ A}$	
		Maximum	2.5 V			
	Holding current	Typical	0.3 mA			
		Maximum	3.5 mA			
Critical rate of rise of OFF-state voltage	Minimum	dv/dt	500 V/ μs		$V_{DRM} = 600 \text{ V} \times 1/\sqrt{2}$	
Transfer characteristics	Trigger LED current	Maximum	I_{FT}	10 mA		$V_D = 6 \text{ V}$ $R_L = 100 \Omega$
	Zero-cross voltage	Maximum	V_{ZC}	50 V	—	$I_F = 10 \text{ mA}$
	Turn on time*	Maximum	T_{on}	100 μs		$I_F = 20 \text{ mA}$ $V_D = 6 \text{ V}$ $R_L = 100 \Omega$
	I/O capacitance	Maximum	C_{iso}	1.5 pF		$f = 1 \text{ MHz}$ $V_B = 0 \text{ V}$
	I/O resistance	Minimum	R_{iso}	50 G Ω		500 V DC

Notes: 1. For type of connection, see page 334.

2. Terminals are either solder plated or solder dipped.

*Turn on time

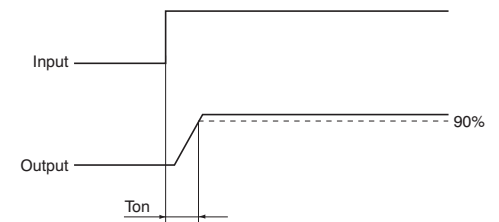

Phototriac Coupler (APT1)

2) Zero-cross voltage type (max. 15V)

Item		Symbol	APT1231S, APT1231(W), APT1232(W)		Condition
Input	LED dropout voltage	Typical	V_F	1.21 V	$I_F = 20 \text{ mA}$
		Maximum		1.3 V	
	LED reverse current	Typical	I_R	—	$V_R = 6 \text{ V}$
		Maximum		10 μA	
Output	Repetitive peak OFF-state current	Typical	I_{DRM}	—	$I_F = 0 \text{ mA}$ $V_{DRM} = 600 \text{ V}$
		Maximum		1 μA	
	Repetitive peak On-state voltage	Typical	V_{TM}	1.2 V	$I_F = 10 \text{ mA}$ $I_{TM} = 0.03 \text{ A}$
		Maximum		2 V	
	Holding current	Typical	I_H	0.3 mA	
		Maximum		3.5 mA	
Critical rate of rise of OFF-state voltage	Minimum	dv/dt	500 V/ μs	$V_{DRM} = 600 \text{ V} \times 1/\sqrt{2}$	
Transfer characteristics	Trigger LED current	Maximum	I_{FT}	10 mA	$I_{DRM} = 30 \text{ mA}$
	Zero-cross voltage	Maximum	V_{ZC}	15 V	$I_F = 10 \text{ mA}$
	Turn on time*	Maximum	T_{on}	100 μs	$I_F = 20 \text{ mA}$ $I_{DRM} = 30 \text{ mA}$
	I/O capacitance	Maximum	C_{iso}	1.5 pF	$f = 1 \text{ MHz}$ $V_B = 0 \text{ V}$
	I/O resistance	Minimum	R_{iso}	50 G Ω	500 V DC

Notes: 1. For type of connection, see page 334.

2. Terminals are either solder plated or solder dipped.

*Turn on time

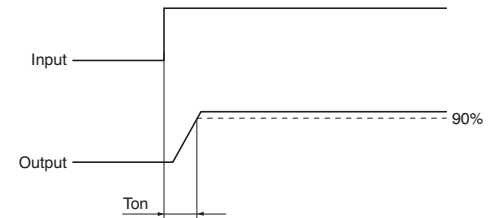

RECOMMENDED OPERATING CONDITIONS

Please follow the conditions below in order to ensure accurate operation and release of the phototriac coupler.

Item	Symbol	Value	Unit
Input LED current	I_F	20	mA

REFERENCE DATA

1-(1). ON-state RMS current vs. ambient temperature characteristics

Allowable ambient temperature: -40°C to $+100^\circ\text{C}$
 -40°F to $+212^\circ\text{F}$

Tested sample: APT1211S, APT1221S

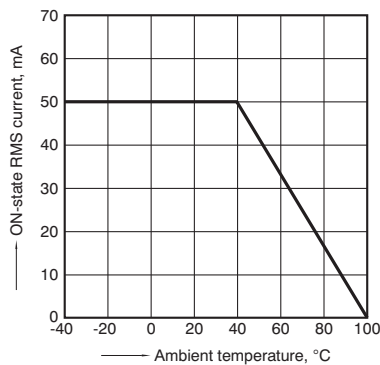

1-(2). ON-state RMS current vs. ambient temperature characteristics

Allowable ambient temperature: -40°C to $+100^\circ\text{C}$
 -40°F to $+212^\circ\text{F}$

Tested sample: APT1231S

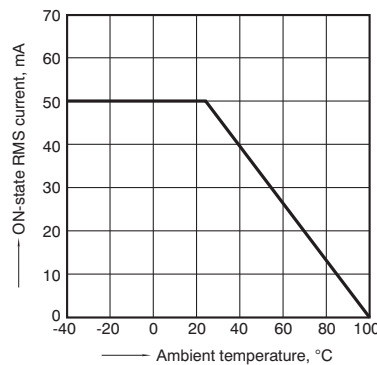

1-(3). ON-state RMS current vs. ambient temperature characteristics

Allowable ambient temperature: -40°C to $+100^\circ\text{C}$
 -40°F to $+212^\circ\text{F}$

Tested sample: APT1211(A), APT1221(A),
APT1211W(A), APT1221W(A)

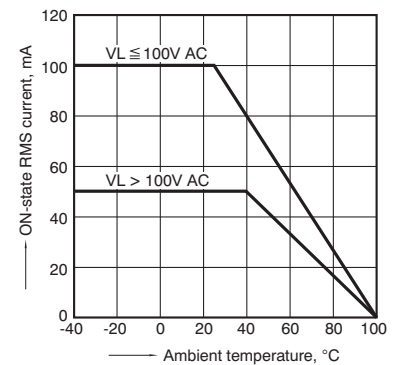

Phototriac Coupler (APT1)

1-(4). ON-state RMS current vs. ambient temperature characteristics

Allowable ambient temperature: -40°C to $+100^{\circ}\text{C}$
 -40°F to $+212^{\circ}\text{F}$

Tested sample: APT1231(A), APT1231W(A)

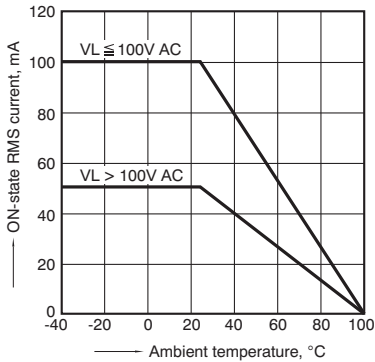

1-(5). ON-state RMS current vs. ambient temperature characteristics

Allowable ambient temperature: -40°C to $+100^{\circ}\text{C}$
 -40°F to $+212^{\circ}\text{F}$

Tested sample: APT1212(A), APT1222(A),
 APT1212W(A), APT1222W(A)

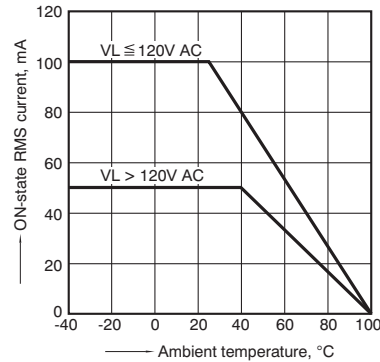

1-(6). ON-state RMS current vs. ambient temperature characteristics

Allowable ambient temperature: -40°C to $+100^{\circ}\text{C}$
 -40°F to $+212^{\circ}\text{F}$

Tested sample: APT1232(A), APT1232W(A)

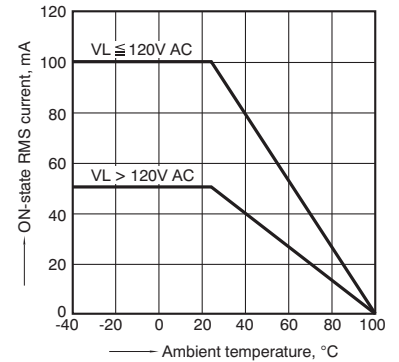

2. On voltage vs. ambient temperature characteristics

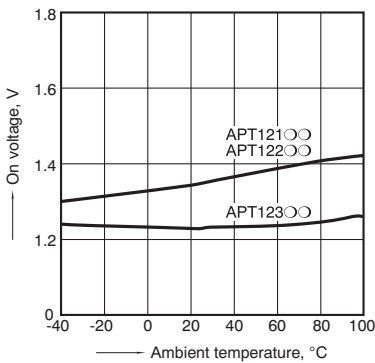

3. Trigger LED current vs. ambient temperature characteristics

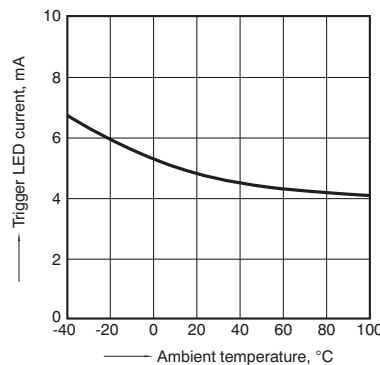

4. LED dropout voltage vs. ambient temperature characteristics

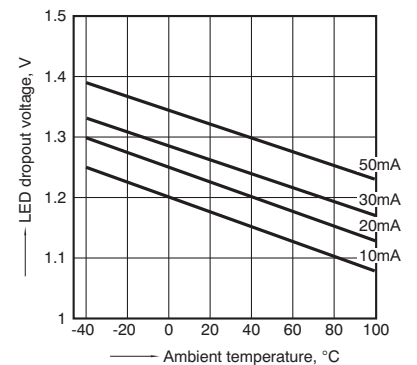

5. Turn on time vs. LED current

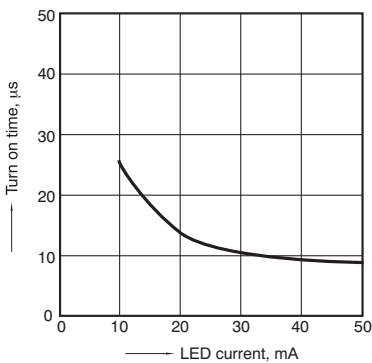

6. Repetitive peak OFF-state current vs. Load voltage characteristics

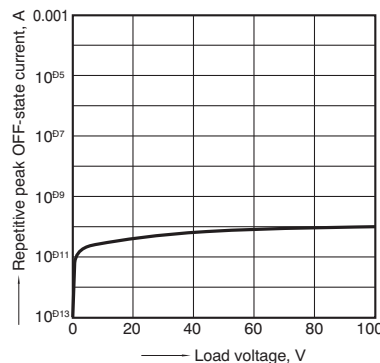

7. Hold current vs. ambient temperature characteristics

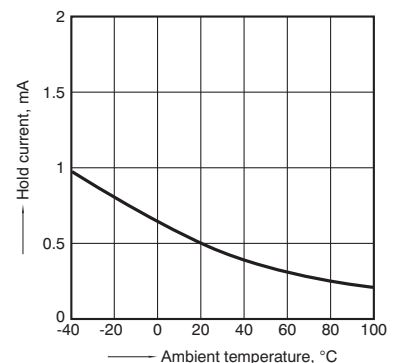

8. Zero-cross voltage vs. ambient temperature characteristics

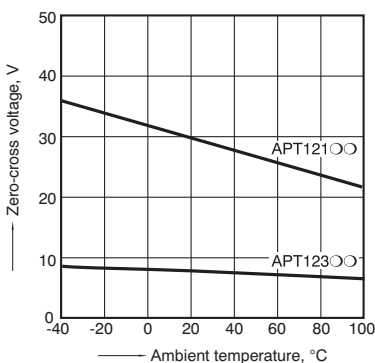

Phototriac Coupler (APT1)

DIMENSIONS (mm inch)

Download [CAD Data](#) from our Web site.

1. SOP Type

APT1211S, APT1221S, APT1231S

[CAD Data](#)

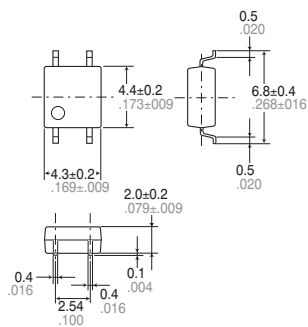

Terminal thickness = 0.15 ± 0.006

General tolerance: $\pm 0.1 \pm 0.004$

Recommended mounting pad (TOP VIEW)

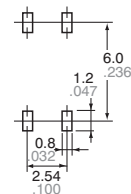

Tolerance: $\pm 0.1 \pm 0.004$

2. DIP4 Type

APT1211(A), APT1221(A), APT1231(A)

[CAD Data](#)



Through hole terminal type

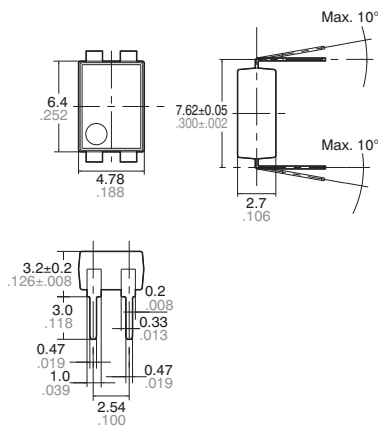

Surface mount terminal type

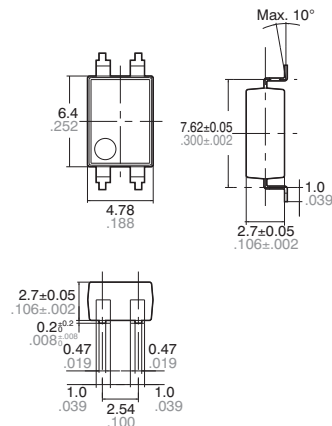

Terminal thickness = 0.2 ± 0.008

General tolerance: $\pm 0.1 \pm 0.004$

PC board pattern (BOTTOM VIEW)

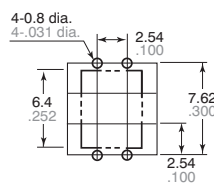

Tolerance: $\pm 0.1 \pm 0.004$

Recommended mounting pad (TOP VIEW)

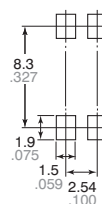

Tolerance: $\pm 0.1 \pm 0.004$

Phototriac Coupler (APT1)

3. DIP4 Wide Terminal Type

APT1211W(A), APT1221W(A), APT1231W(A)

CAD Data

Through hole terminal type

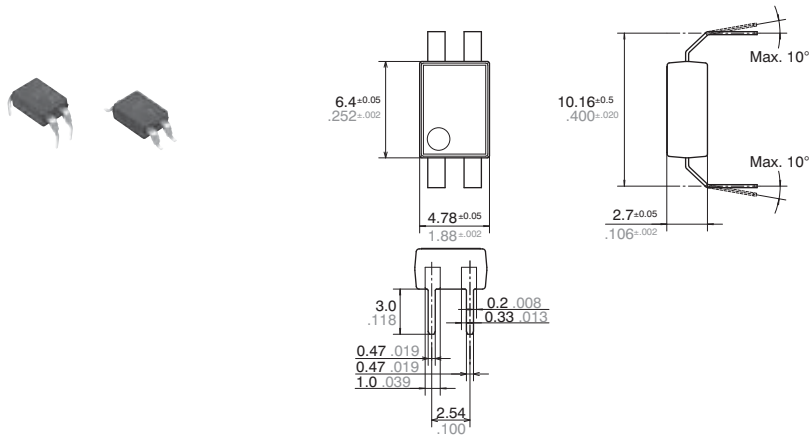

Surface mount terminal type

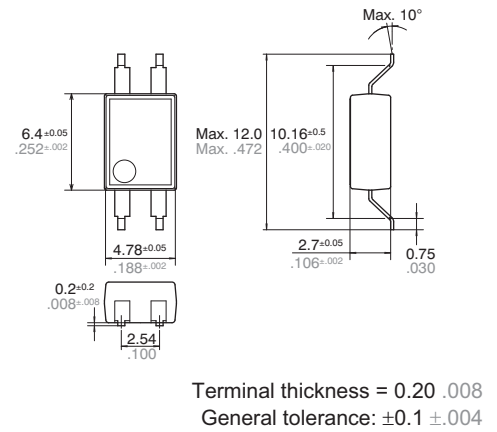

Terminal thickness = 0.20 ±0.008
General tolerance: ±0.1 ±0.004

PC board pattern (BOTTOM VIEW)

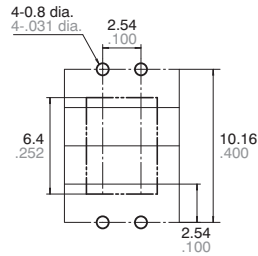

Tolerance: ±0.1 ±0.004

Recommended mounting pad (TOP VIEW)

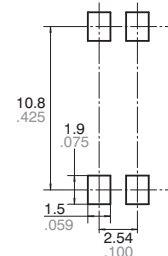

Tolerance: ±0.1 ±0.004

4. DIP6 Type

APT1212(A), APT1222(A), APT1232(A)

CAD Data

Through hole terminal type

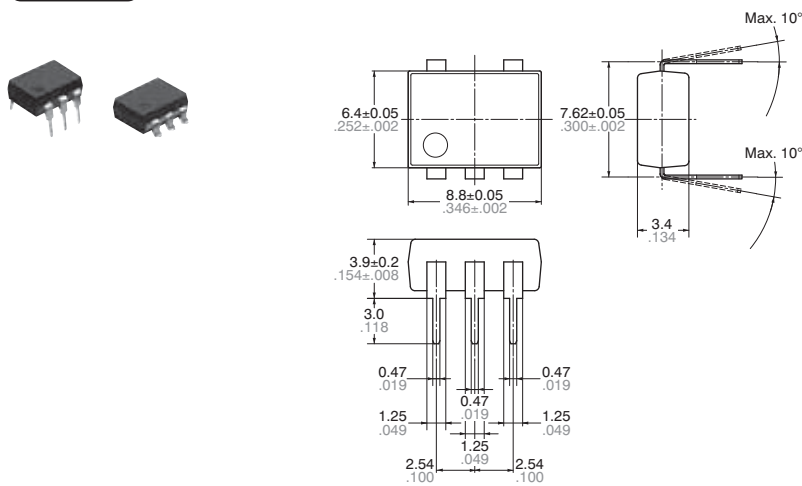

Surface mount terminal type

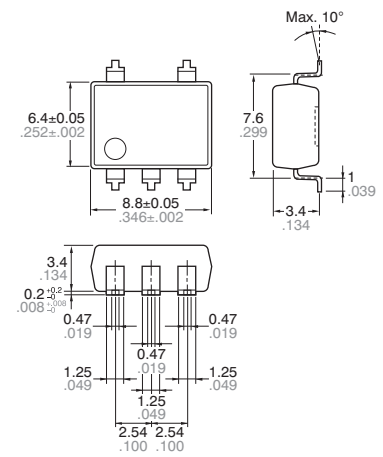

Terminal thickness = 0.25 ±0.010
General tolerance: ±0.1 ±0.004

PC board pattern (BOTTOM VIEW)

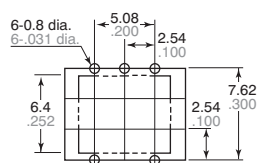

Tolerance: ±0.1 ±0.004

Recommended mounting pad (TOP VIEW)

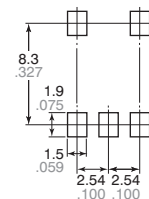

Tolerance: ±0.1 ±0.004

Phototriac Coupler (APT1)

5. DIP6 Wide Terminal Type

APT1212W(A), APT1222W(A), APT1232W(A)

CAD Data



Through hole terminal type

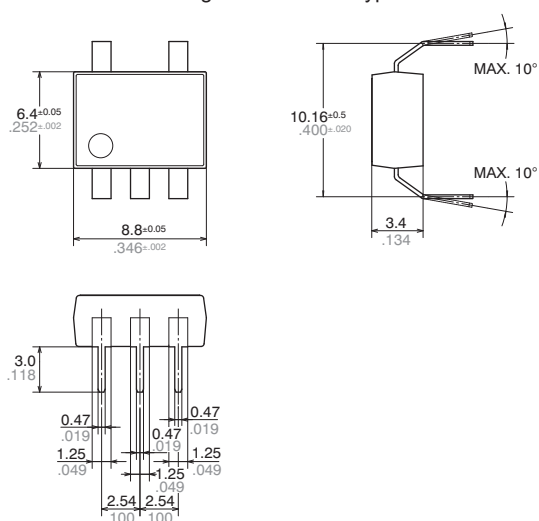

Surface mount terminal type

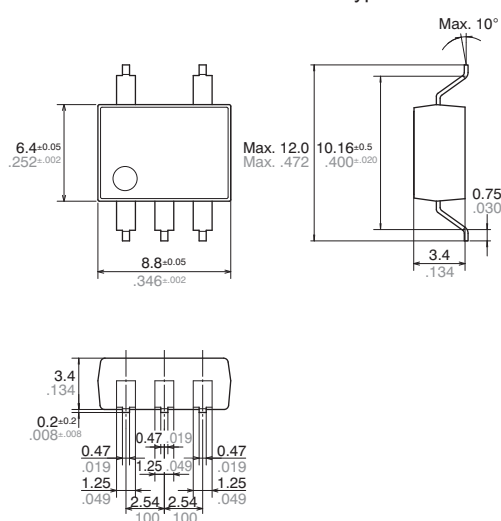

Terminal thickness = 0.25 ±0.01
General tolerance: ±0.1 ±0.04

PC board pattern (BOTTOM VIEW)

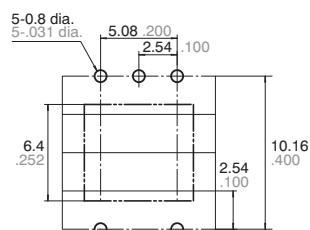

Tolerance: ±0.1 ±0.04

Recommended mounting pad (TOP VIEW)

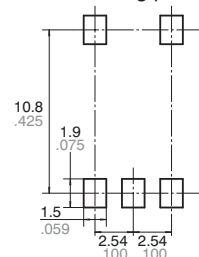

Tolerance: ±0.1 ±0.04

SCHEMATIC AND WIRING DIAGRAMS

Notes: E1: Power source at input side; IF: LED forward current; VL: Load voltage; IL: Load current;

Schematic	Output configuration	Load	Wiring diagram
	1 Form A	AC	

For Cautions for Use, see Page 315.

Panasonic

ideas for life

0.3A to 1.2A compact DIP type

AQ-H RELAYS

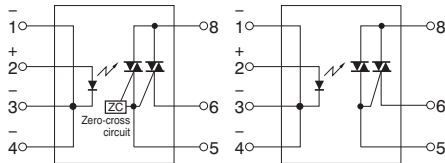

FEATURES

1. Compact DIP type SSR that's ideal for AC load control
2. Supports 0.3 A, 0.6 A, 0.9 A and 1.2 A ON-state RMS currents.
3. The 1.2 A type saves space with a DIP 8-pin package.

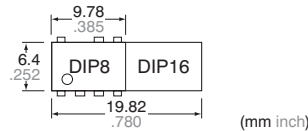

4. Handles both 100 and 200 V AC loads
This relay handles both voltages in a single product. It is not necessary for users that use both types to manage separate part numbers.

5. High dielectric strength: 5,000 V AC (between input and output)
6. Two types available: Zero-cross type and Random type

TYPICAL APPLICATIONS

1. Home appliances (air conditioner, microwave oven, washing machine, personal hygiene system, refrigerator, fan heater, inductive heating cooker, rice cooker and humidifier, etc.)
2. Industrial equipment

Solid State

TYPES

Type	Output rating*		Type	Part No.				Packing quantity	
				Through hole terminal	Surface-mount terminal			Tube	Tape and reel
	Tube packing style				Tape and reel packing style				
AC type	600 V	ON-state RMS current	Zero-cross	AQH0213	AQH0213A	AQH0213AX	AQH0213AZ	1 tube contains 50 pcs. 1 batch contains 500 pcs.	1,000 pcs.
				AQH1213	AQH1213A	AQH1213AX	AQH1213AZ		
				AQH2213	AQH2213A	AQH2213AX	AQH2213AZ		
				AQH3213	AQH3213A	AQH3213AX	AQH3213AZ		
		Random	AQH0223	AQH0223A	AQH0223AX	AQH0223AZ			
			AQH1223	AQH1223A	AQH1223AX	AQH1223AZ			
			AQH2223	AQH2223A	AQH2223AX	AQH2223AZ			
			AQH3223	AQH3223A	AQH3223AX	AQH3223AZ			
			Picked from the 1/2/3/4-pin side	Picked from the 5/6/8-pin side					

*Indicate the repetitive peak OFF-state voltage and ON-state RMS current: peak AC.

Note: For space reasons, the SMD terminal shape indicator "A" and the package type indicator "X" and "Z" are omitted from the seal.

RATING

1. Absolute maximum ratings (Ambient temperature: 25°C 77°F)

Item	Symbol	AQH0213, AQH0223	AQH1213, AQH1223	AQH2213, AQH2223	AQH3213, AQH3223	Remarks
Input	LED forward current	I _F				50 mA
	LED reverse voltage	V _R				6 V
	Peak forward current	I _{FP}				1 A
Output	Repetitive peak OFF-state voltage	V _{DRM}				600 V
	ON-state RMS current	I _{T(RMS)}	0.3 A	0.6 A	0.9 A	1.2 A
	Non-repetitive surge current	I _{TSM}	3 A	6 A	9 A	12 A
I/O isolation voltage	V _{ISO}	5,000 V AC				
Temperature limits	Operating	T _{opr}	-30°C to +85°C -22°F to +185°F			Non-condensing at low temperatures
	Storage	T _{stg}	-40°C to +125°C -40°F to +257°F			

Note: "A", "AX" and "AZ" at the end of the part numbers have been omitted.

AQ-H

2. Electrical characteristics (Ambient temperature: 25°C 77°F)

Item		Symbol	AQH0213, AQH1213, AQH2213, AQH3213	AQH0223, AQH1223, AQH2223, AQH3223	Condition
Input	LED dropout voltage	Typical	1.21 V		$I_F = 20 \text{ mA}$
		Maximum	1.3 V		
	LED reverse current	Typical	—		$V_R = 6 \text{ V}$
		Maximum	10 μA		
Output	Peak OFF-state current	Typical	—		$I_F = 0 \text{ mA}$ $V_{DRM} = 600 \text{ V}$
		Maximum	100 μA		
	Peak ON-state voltage	Typical	—		$I_F = 10 \text{ mA}$ $I_{TM} = \text{Max.}$
		Maximum	2.5 V		
	Holding current	Typical	—		
		Maximum	25 mA		
Critical rate of rise of OFF-state voltage	Minimum	dv/dt	200 V/ μs		$V_{DRM} = 600 \text{ V} \times 1/M2$
Transfer characteristics	Trigger LED current	Maximum	10 mA		$V_D = 6 \text{ V}$ $R_L = 100 \Omega$
	Zero-cross voltage	Maximum	50 V	—	$I_F = 10 \text{ mA}$
	Turn on time*	Maximum	100 μs		$I_F = 20 \text{ mA}$ $V_D = 6 \text{ V}$ $R_L = 100 \Omega$
	I/O isolation resistance	Minimum	R_{iso}	50 G Ω	

Notes: 1. For type of connection, see page 337.
2. "A", "AX" and "AZ" at the end of the part numbers have been omitted.

RECOMMENDED OPERATING CONDITIONS

Please follow the conditions below in order to ensure accurate operation and release of the phototriac coupler.

Item	Symbol	Value	Unit
Input LED current	I_F	20	mA

*Turn on time

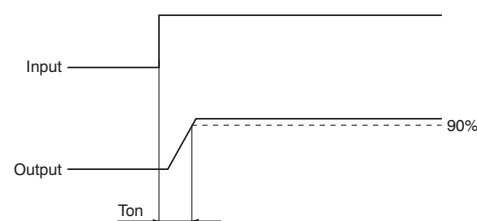

REFERENCE DATA

1. ON-state RMS current vs. Ambient temperature characteristics
Allowable ambient temperature: -30°C to +85°C -22°F to +185°F

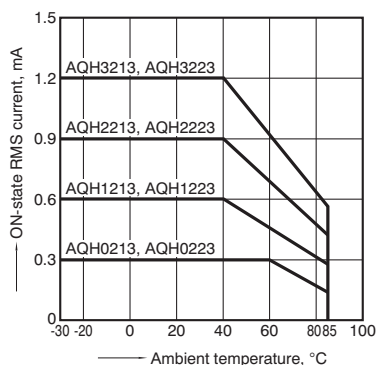

2. On voltage vs. Ambient temperature characteristics
LED current: 10 mA; ON current: Max.
Measured portion: between terminals 6 and 8

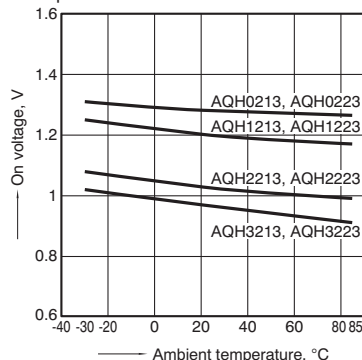

3. Trigger LED current vs. Ambient temperature characteristics
Load voltage: 6 V DC;
Load resistance: 100 Ω

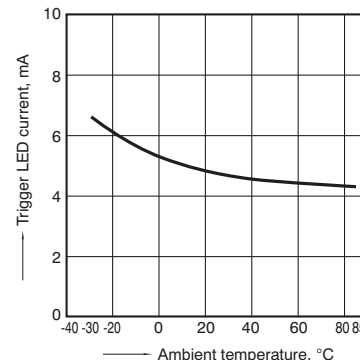

4. LED dropout voltage vs. Ambient temperature characteristics
LED current: 10 to 50 mA

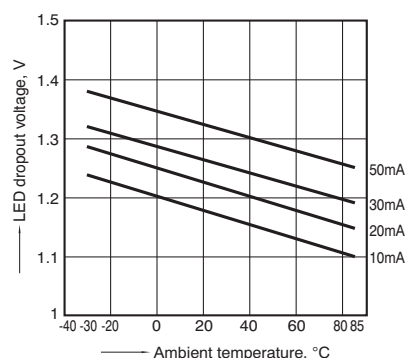

5. Turn on time vs. LED current characteristics
Load voltage: 6 V DC; Load resistance: 100 Ω
Measured portion: between terminals 6 and 8

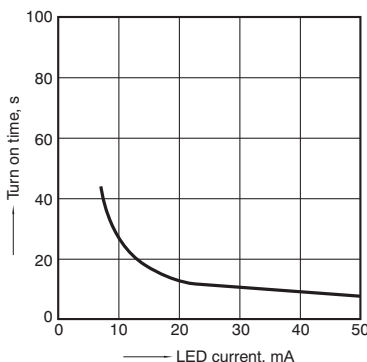

6. Repetitive peak OFF-state current vs. Load voltage characteristics
LED current: 0 mA; Measured portion: between terminals 6 and 8; Ambient temperature: 25°C 77°F

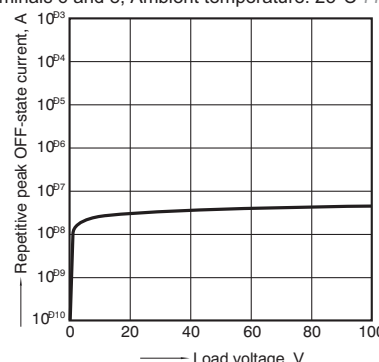

7. Hold current vs. Ambient temperature characteristics

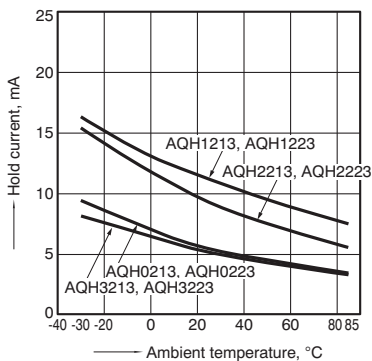

8. Zero-cross voltage vs. Ambient temperature characteristics

LED current: 10 mA

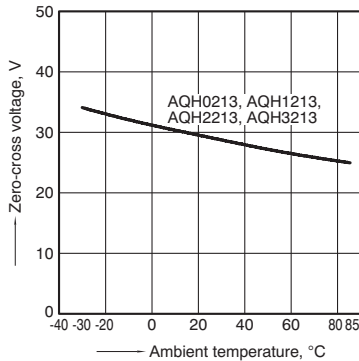

DIMENSIONS (mm inch)

Download **CAD Data** from our Web site.

Through hole terminal type

CAD Data

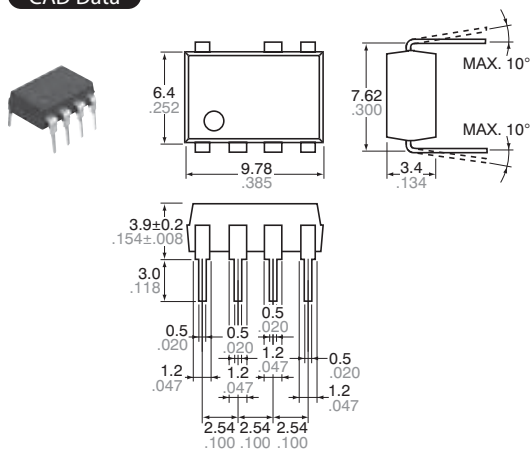

Terminal thickness: 0.25 .010
General tolerance: $\pm 0.1 \pm .004$

Surface mount terminal type

CAD Data

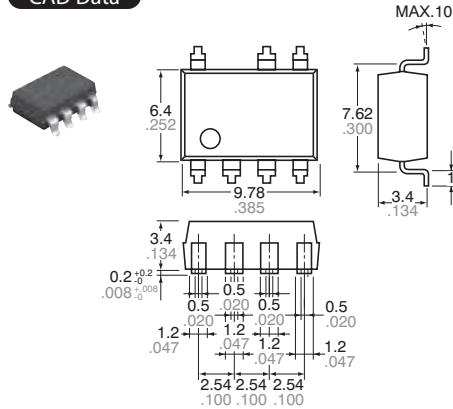

Terminal thickness: 0.25 .010
General tolerance: $\pm 0.1 \pm .004$
PC board pattern

(BOTTOM VIEW)

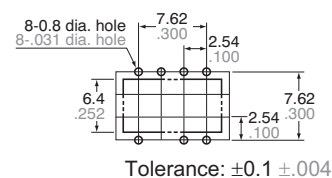

Tolerance: $\pm 0.1 \pm .004$

Recommended mounting pad (TOP VIEW)

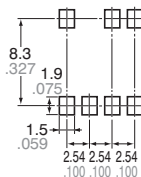

Tolerance: $\pm 0.1 \pm .004$

SCHEMATIC AND WIRING DIAGRAMS

Notes: E₁: Power source at input side; I_F: Trigger LED forward current; V_L: Load voltage; I_L: Load current;

Schematic	Output configuration	Load	Wiring diagram
	1a	AC	

For Cautions for Use, see Page 315.



Panasonic
ideas for life

1A and 2A space saving PC
board terminal type

AQ-G RELAYS

FEATURES

1. Space saving, Vertical size with a maximum thickness of 4.5 mm.

Mounting space has been reduced to 30% (compared to conventional SSR's) while meeting high density PC board mounting requirements.

2. 1A and 2A load types available

3. Zero-cross type and Non zero-cross type available

4. High dielectric strength of 3,000V AC

(between input and output)

5. Snubber circuit integrated

The snubber circuit is integrated to prevent malfunction caused by the rapid rise of voltage on the output side, such as inductive load and current.

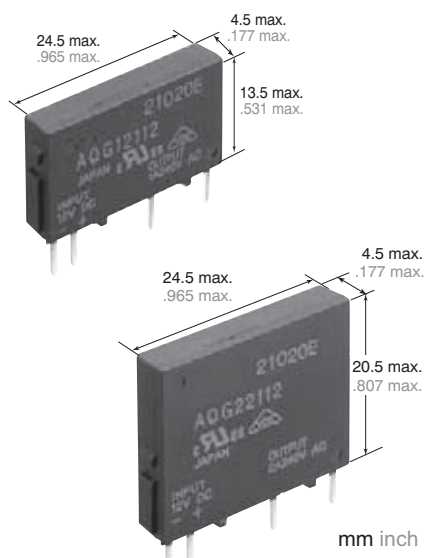

mm inch

TYPES

Type	Load current	Load voltage	Input voltage	Part No.
Zero-cross	1A	75 to 264 V AC	5 V DC	AQG12105
			12 V DC	AQG12112
			24 V DC	AQG12124
	2A	75 to 264 V AC	5 V DC	AQG22105
			12 V DC	AQG22112
			24 V DC	AQG22124
Non zero-cross	1A	75 to 264 V AC	5 V DC	AQG12205
			12 V DC	AQG12212
			24 V DC	AQG12224
	2A	75 to 264 V AC	5 V DC	AQG22205
			12 V DC	AQG22212
			24 V DC	AQG22224

TYPICAL APPLICATIONS

- Manufacturing equipment
 - NC machines
 - Injection molders
 - Robots
- Air conditioners
- Computers

ORDERING INFORMATION

Ex. AQG 1 2 1 0 5

Load current	Load voltage	Type	Input voltage
1: 1 A 2: 2 A	2: 75 to 264 V AC	1: Zero-cross (3,000 V) 2: Non zero-cross (3,000 V)	05: 5 V DC 12: 12 V DC 24: 24 V DC

(Note) Standard packing: Carton 20 pcs., Case 500 pcs.

SPECIFICATIONS

1. Ratings (at 20°C 68°F, Input voltage ripple: 1% or less)

1) Zero-cross type

Item	Type	Part No.						Remarks
		AQG12105	AQG12112	AQG12124	AQG22105	AQG22112	AQG22124	
Input side	Input voltage	4 to 6 V DC	9.6 to 14.4 V DC	19.2 to 28.8 V DC	4 to 6 V DC	9.6 to 14.4 V DC	19.2 to 28.8 V DC	
	Input impedance	Approx. 0.3k Ω	Approx. 0.8k Ω	Approx. 1.6k Ω	Approx. 0.3k Ω	Approx. 0.8k Ω	Approx. 1.6k Ω	
	Drop-out voltage, min.	1 V						
	Reverse voltage	3 V						
Load side	Max. load current	1 A AC			2 A AC			
	Load voltage	75 to 264 V AC						
	Frequency	45 to 65 Hz						
	Non-repetitive surge current	8 A			30 A			In one cycle at 60 Hz
	Max. "OFF-state" leakage current	1.5 mA (applied 200 V)						
	Max. "ON-state" voltage drop	1.6 V						at Max. carrying current
	Min. load current	20 mA						

2) Non zero-cross type

Item	Type	Part No.						Remarks
		AQG12205	AQG12212	AQG12224	AQG22205	AQG22212	AQG22224	
Input side	Input voltage	4 to 6 V DC	9.6 to 14.4 V DC	19.2 to 28.8 V DC	4 to 6 V DC	9.6 to 14.4 V DC	19.2 to 28.8 V DC	
	Input impedance	Approx. 0.3k Ω	Approx. 0.8k Ω	Approx. 1.6k Ω	Approx. 0.3k Ω	Approx. 0.8k Ω	Approx. 1.6k Ω	
	Drop-out voltage, min.	1 V						
	Reverse voltage	3 V						
Load side	Max. load current	1 A AC			2 A AC			
	Load voltage	75 to 264 V AC						
	Frequency	45 to 65 Hz						
	Non-repetitive surge current	8 A			30 A			In one cycle at 60 Hz
	Max. "OFF-state" leakage current	1.5 mA (applied 200 V)						
	Max. "ON-state" voltage drop	1.6 V						at Max. carrying current
	Min. load current	20 mA						

2. Characteristics (at 20°C 68°F, Input voltage ripple: 1% or less)

Item	Zero-cross type	Non zero-cross type	Remarks
Operate time max.	(1/2 cycle of voltage sine wave) + 1 ms	1 ms	
Release time, max.	(1/2 cycle of voltage sine wave) + 1 ms		
Insulation resistance, min.	10 ⁹ Ω between input and output		Using 500 V DC megger
Breakdown voltage	3,000 Vrms between input and output		Initial for 1 min.
Vibration resistance	10 to 55 Hz double amplitude of 0.75 mm		X, Y, Z axes
Shock resistance	1,000 m/s ²		X, Y, Z axes
Ambient temperature	-30°C to +80°C -22°F to +176°F		Non-condensing at low temperatures
Storage temperature	-30°C to +100°C -22°F to +212°F		
Operational method	Zero-cross (Turn-ON and Turn-OFF)	Non zero-cross turn ON, Zero-cross turn OFF	

AQ-G

DIMENSIONS (mm inch)

Download **CAD Data** from our Web site.

1. 1A type

CAD Data

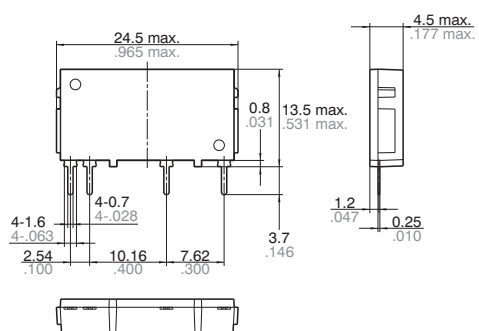
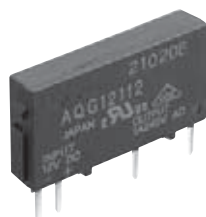

General tolerance: $\pm 0.2 \pm .008$

PC board pattern (Bottom view)



Tolerance: $\pm 0.1 \pm .004$

Schematic AC type



2. 2A type

CAD Data

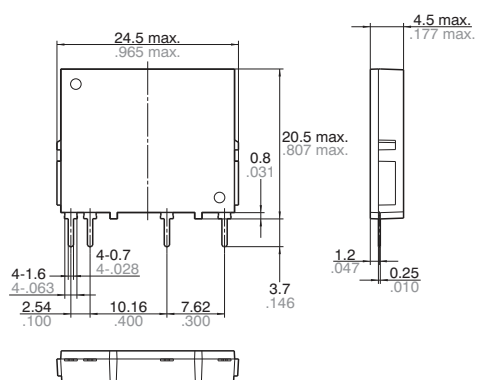

General tolerance: $\pm 0.2 \pm .008$

PC board pattern (Bottom view)

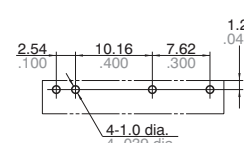

Tolerance: $\pm 0.1 \pm .004$

Schematic AC type



REFERENCE DATA

1. Load current vs. ambient temperature

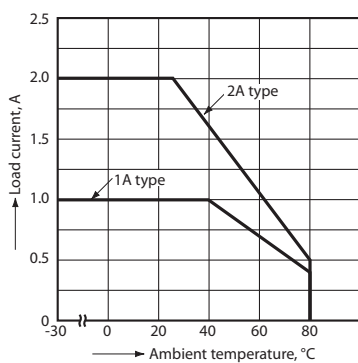

2-(1) Non-repetitive surge current vs. carrying time (1A type)

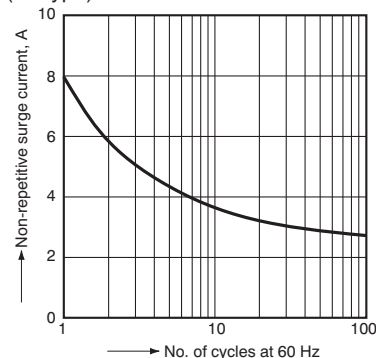

2-(2) Non-repetitive surge current vs. carrying time (2A type)

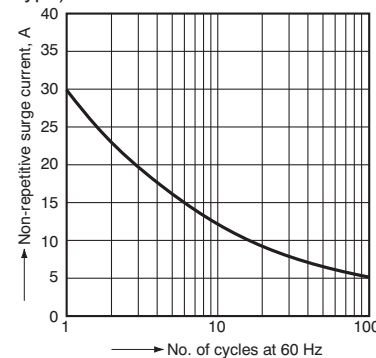

3. Input current vs. input voltage characteristics

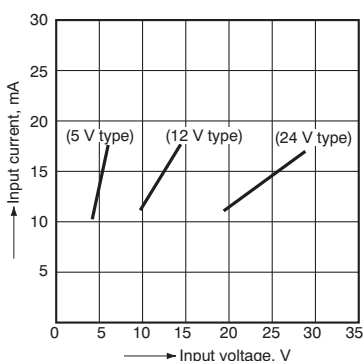

4-(1) Load current vs. ambient temperature characteristics for adjacent mounting (1A type)

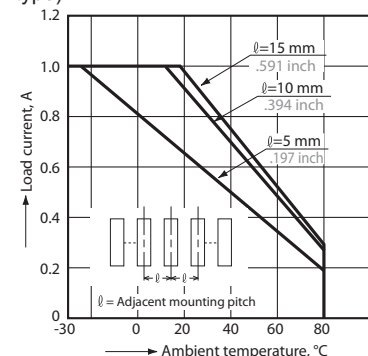

4-(2) Load current vs. ambient temperature characteristics for adjacent mounting (2A type)

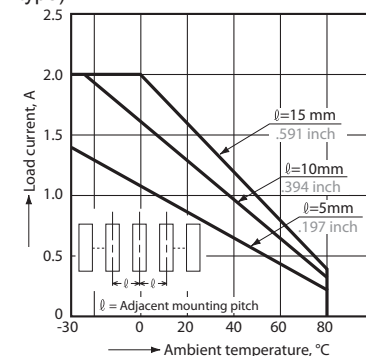

For Cautions for Use, see Page 319.

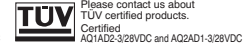
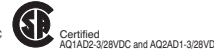

Panasonic

ideas for life

High capacity up to 10A PC board terminal type

AQ1 RELAYS

FEATURES

1. 10A high-capacity realized for PC board terminal (with heat sink)

SSR for compact PC boards with 10 A capacity that is two times greater than our previous model. It is suitable for long-life, highly frequent control.

2. VDE (EN60950-1) reinforced insulation compliant

Fully satisfies demand for safety by guaranteeing compliance with EN60950-1 safety standard and featuring 3,000 V reinforced insulation (AQ3A2-ZT4/32VDC, AQ3A2-J-ZT4/32VDC and AQ10A2-ZT4/32VDC).

3. Superior anti-vibration and anti-shock characteristics

The body is molded as a single unit with flame resistant resin which makes it highly resistant against vibration and shock, and gives it superior protection from environment. The body can also be washed.

4. Vertical types with SIL terminal arrangement and flat types are available.

1) The vertical type is available in thicknesses of 10 mm (2 A and 3 A types) and 12 mm (5 A and 10 A types).

Terminal arrangement is SIL in integral multiples of 2.54 mm (0.1 inch).

2) The height of the flat type is 12 mm.

The terminal arrangement is DIL in integral multiples of 2.54 mm.

5. Reduced noise generation

The load will operate at close to zero voltage even when the input signal is applied during a cycle. Also, even if an input signal is cancelled during a cycle, the load is cut off at close to zero current.

For this reason, hardly any noise is produced and radio frequency interference (RFI) and electromagnetic interference (EMI) are kept to a minimum.

6. Built-in Snubber circuit prevents malfunction.

TYPICAL APPLICATIONS

- Printing machines
- Packing machines
- Traffic signal control
- Automatic ticket punchers
- Terminal equipment of data processing
- Computer peripherals
- NC machines

Solid State

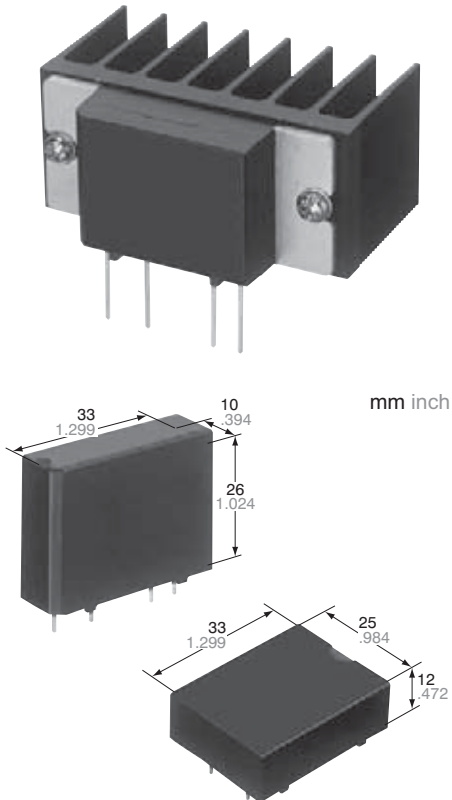

ORDERING INFORMATION

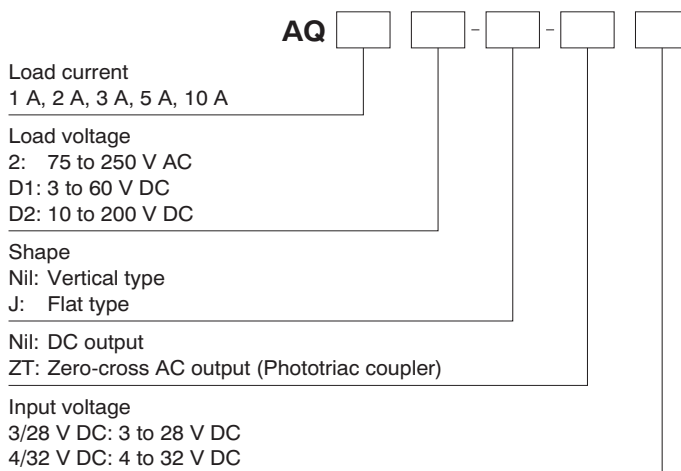

* Random types are available upon request.

AQ1

TYPES

1. AQ1 Solid State Relays

Load	Isolation	Zero-cross function	Type	Input voltage	Load current Load voltage	Part No.
AC	Phototriac coupler	Zero-cross*1	3 A (Vertical)	4 to 32 V DC	3 A, 75 to 250 V AC	AQ3A2-ZT4/32VDC
			3 A (flat)	4 to 32 V DC	3 A, 75 to 250 V AC	AQ3A2-J-ZT4/32VDC
			10 A	4 to 32 V DC	10 A, 75 to 250 V AC (5 A without heat sink)	AQ10A2-ZT4/32VDC
DC	Optically coupled isolation	-	1 A	3 to 28 V DC	1 A, 10 to 200 V DC	AQ1AD2-3/28VDC
			2 A	3 to 28 V DC	2 A, 3 to 60 V DC	AQ2AD1-3/28VDC

Standard packing: Carton 20 pcs., Case 200 pcs.

Note: *1 Non zero-cross type also available. Please inquire.

2. Heat sink for AQ1 solid state relay

Product name	Part No.
Heat sink for AQ10A2-ZT4/32VDC	AQ-HS-5A

Standard packing: Carton 20 pcs., Case 200 pcs.

SPECIFICATIONS

1. Rating (at 20°C 68°F, Ripple factor: less than 1%)

Item	Type	AC output type		DC output type		Remarks
		Zero-cross		1 A type	2 A type	
		3 A type	10 A type			
Input side	Input voltage	4 to 32 V DC		3 to 28 V DC		
	Input impedance	—		Approx. 1.6 kΩ (3 to 28 V DC)		
	Input current, max.	20 mA		—		
	Drop-out voltage, min.	1.0 V		0.8 V		
Load side	Max. load current	3 A	10 A*1	1 A	2 A	Refer to "REFERENCE DATA 1. Load current vs. ambient temperature characteristics".
	Load voltage	75 to 250 V AC		10 to 200 V DC	3 to 60 V DC	
	Non-repetitive surge current	100 A		5 A (1 s)		AC: In one cycle at 60 Hz, DC: 1s
	Max. "OFF-state" leakage current	5 mA		1 mA		AC: at 200 V, 60Hz DC: When maximum load voltage is applied.
	Max. "ON-state" voltage drop	1.6 V		1.6 V	2.3 V	At Max. carrying current
	Min. load current	50 mA*3		5 mA*3		

Notes: *1 When heat sink (AQ-HS-5A) is installed. The max. load current is 5 A when heat sink is not installed.

*2 When heat sink (AQ-HS-5A) is installed. The max. load current is 3 A when heat sink is not installed.

*3 When load current is below the rating, refer to "Cautions for Use" on page 346.

2. Characteristics (at 20°C 68°F, Ripple factor: less than 1%)

Item	Type	AC output		DC output	Remarks
		Zero-cross			
		3 A type	10 A type		
Operate time, Max.	(1/2 cycle of voltage sine wave) + 1 ms		0.5 ms		
Release time, Max.	(1/2 cycle of voltage sine wave) + 1 ms		2 ms		
Insulation resistance, Min.	100 M Ω for input, output and case		100 M Ω for input, output	at 500 V DC	
Breakdown voltage	4,000 Vrms between input and output 2,500 Vrms among input, output and case		3,000 Vrms between input-output	For 1 minute	
Vibration resistance	Destructive	117.6 m/s ² {12G}, 10 to 55 Hz at double amplitude of 2 mm		117.6 m/s ² {12G}, 10 to 55 Hz at double amplitude of 2 mm	1 hour for X, Y, Z axis
	Functional	117.6 m/s ² {12G}, 10 to 55 Hz at double amplitude of 2 mm		117.6 m/s ² {12G}, 10 to 55 Hz at double amplitude of 2 mm	10 minutes for X, Y, Z axis
Shock resistance	Destructive	Min. 980 m/s ² {100 G}		Min. 980 m/s ² {100 G}	5 times each for X, Y, Z axis
	Functional	Min. 980 m/s ² {100 G}		Min. 980 m/s ² {100 G}	4 times each for X, Y, Z axis
Ambient temperature	-30°C to +80°C -22°F to +176°F				
Storage temperature	-30°C to +100°C -22°F to +212°F				
Operational method	Zero-cross (Turn-ON and Turn-OFF)		—		

REFERENCE DATA

1-(1) Load current vs. ambient temperature
(AC output, 3 A type) Part No.: AQ3A2-ZT4/32VDC
and AQ3A2-J-ZT4/32VDC
Allowable ambient temperature:
-30°C to +80°C -22°F to +176°F

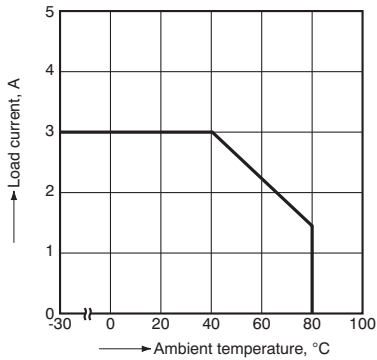

1-(2) Load current vs. ambient temperature
(AC output, 10 A type) Part No.: AQ10A2-ZT4/32VDC
(A) When not using a heat sink AQ-HS-5A
(B) When using a standard heat sink AQ-HS-5A
(When attached to a heat sink, use a heat conductive compound (Ex. Toshiba silicone YG6111 or TSK5303) of similar coating to improve cooling.)

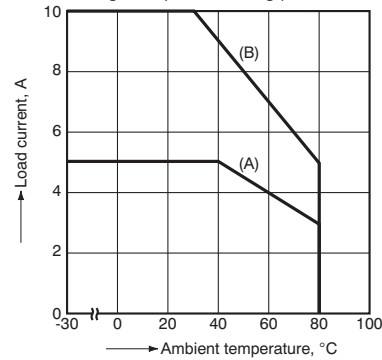

1-(3) Load current vs. ambient temperature
(DC output, 1 A and 2 A types) Part No.: AQ1AD2-3/28VDC and AQ2AD1-3/28VDC
Allowable ambient temperature:
-30°C to +80°C -22°F to +176°F

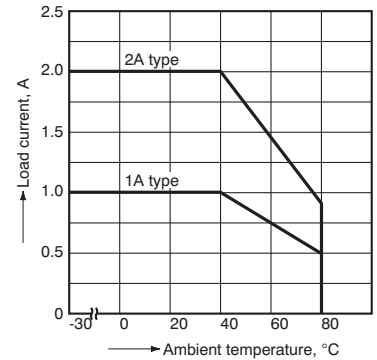

2-(1) Non-repetitive surge current vs. carrying time

(AC output, 3 A and 10 A types)
Part No.: AQ3A2-ZT4/32VDC, AQ3A2-J-ZT4/32VDC
and AQ10A2-ZT4/32VDC

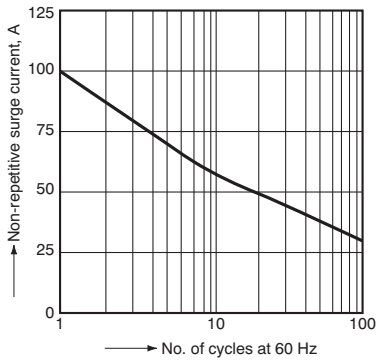

2-(2) Non-repetitive surge current vs. carrying time

(DC output) Part No.: AQ1AD2-3/28VDC and AQ2AD1-3/28VDC

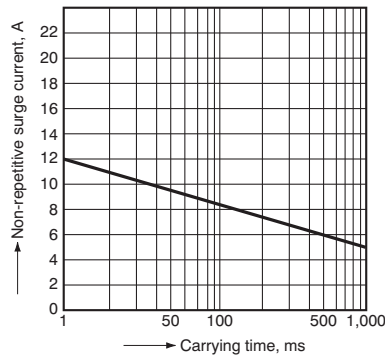

3-(1) Input current vs. input voltage characteristics

(AC output, 3 A and 10 A types)
Part No.: AQ3A2-ZT4/32VDC, AQ3A2-J-ZT4/32VDC
and AQ10A2-ZT4/32VDC

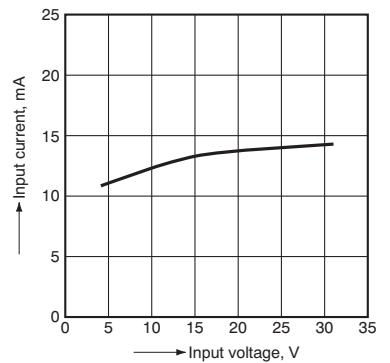

AQ1

DIMENSIONS (mm inch)

Download **CAD Data** from our Web site.

1. AC output, 3A types (Vertical)

CAD Data

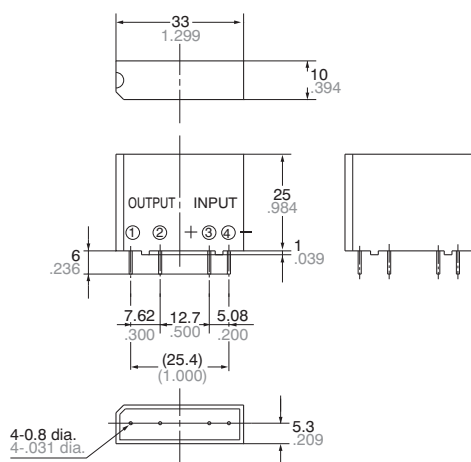

General tolerance: $\pm 0.5 \pm .020$

Mounting hole location (Copper-side view)

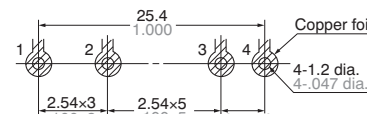

Schematic

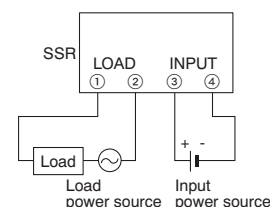

Tolerance: $\pm 0.1 \pm .004$

2. AC output, 3A types (Flat)

CAD Data

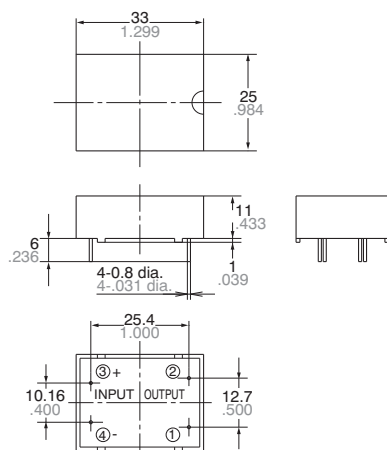
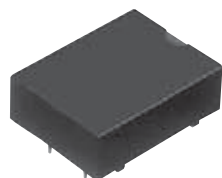

General tolerance: $\pm 0.5 \pm .020$

Mounting hole location (Copper-side view)

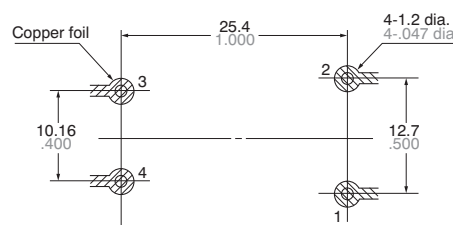

Schematic

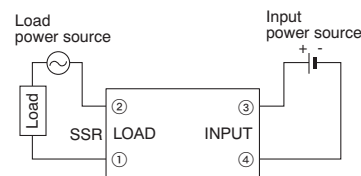

Tolerance: $\pm 0.1 \pm .004$

3. AC output, 10A types

CAD Data

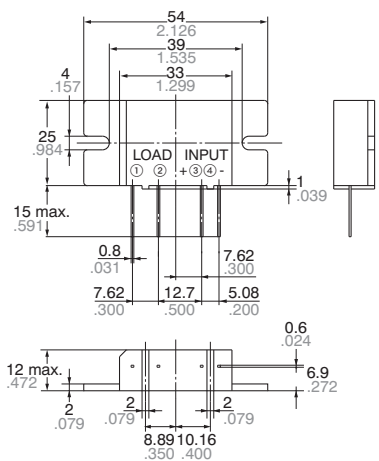
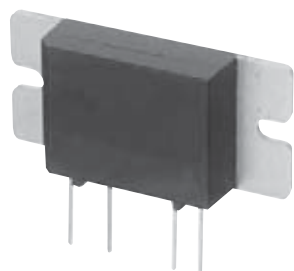

General tolerance: $\pm 0.5 \pm .020$

Mounting hole location (Copper-side view)

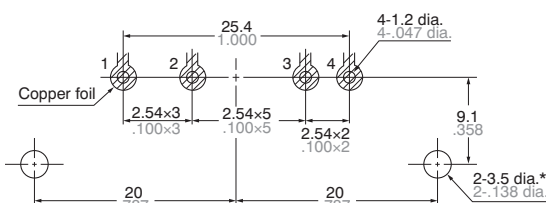

* There 2 holes are not necessary when not using heat sink (AQ-HS-5A)

Schematic

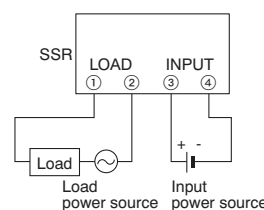

Tolerance: $\pm 0.1 \pm .004$

AQ1

mm inch

4. Heat sink (for AQ10A2-ZT4/32VDC)

CAD Data

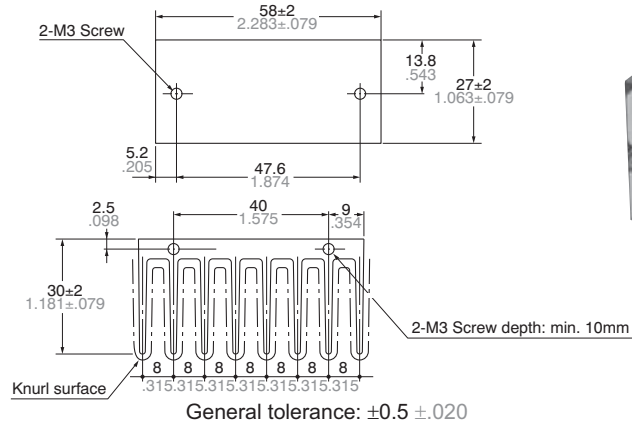

CAD Data

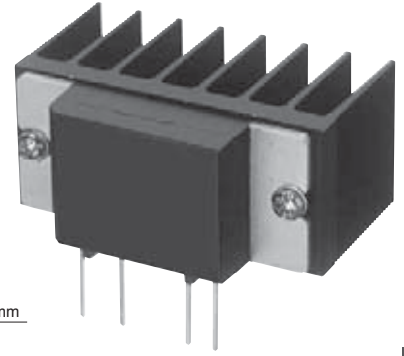

Heat sink attached to AQ1 relay

5. DC output, 1A and 2A types

CAD Data

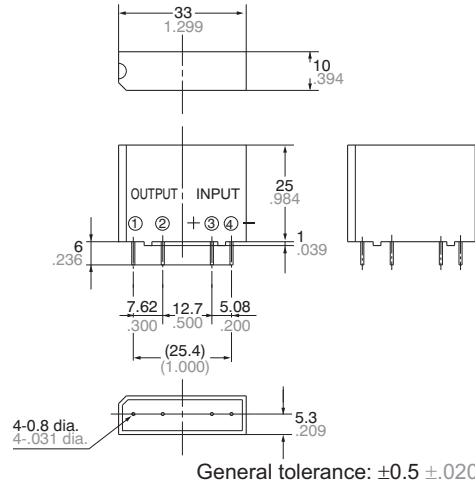
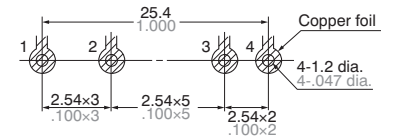
Mounting hole location
(Copper-side view)

Schematic

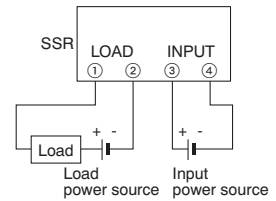
Tolerance: $\pm 0.1 \pm 0.004$

AQ1

CAUTIONS FOR USE

1. Input side

1) Noise and surge protection at the input side

A high noise surge voltage applied to the SSR input circuit can cause malfunction or permanent damage to the device. If such a high surge is anticipated, use C or R noise absorber in the input circuit.

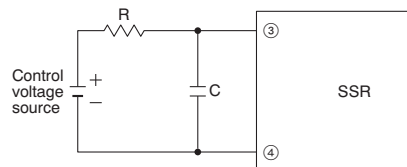

2) When the input terminals are connected with reverse polarity
Reversing the polarity will not cause damage to the device, due to the presence of a protection diode, but the device will not operate.

3) In the case of operating voltage containing ripple

If the SSR control voltage contains ripple, the peak of the ripple should not exceed the maximum rated control voltage "32V", and the bottom of the ripple should exceed the minimum rated control voltage "4V".

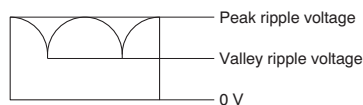

2. Output side

1) Regarding output noise surge protection

A high noise surge voltage applied to the SSR load circuit can cause malfunction or permanent damage to the device. If such a high surge is anticipated, use a varistor across the SSR output.

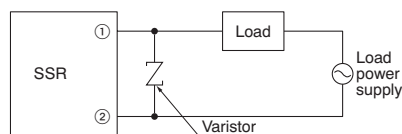

Keep the varistor voltage to no more than 500 V.

2) When used for the load less than rated
An SSR may malfunction if it is used below the specified load. In such an event, use a dummy resistor in parallel with the load.

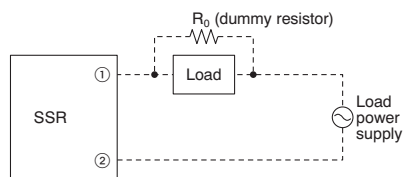

Set a value of dummy resistor so that the load current becomes 50 mA or greater due to the dummy resistor and load.

3. When using bent output terminals

To avoid applying mechanical stress on the main unit and molded section of the solid state relay, radio pliers should be used to grasp the terminals between the point of bending and the molded case when making the bends.

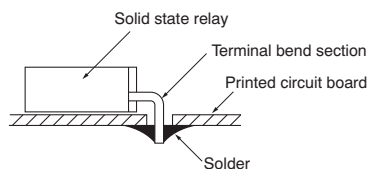

4. When a heat sink is mounted on the 5 A or 10 A type

The heat sink (AQ-HS-5A) or a radiator which can make good contact should be used.

If a heat sink is used in which the contact condition is bad, a heat conducting compound should be used to improve the heat radiation. (Ex. Silicon compound Toshiba silicon YG6111 or TSK5303) The compound should be applied between the heat sink and the AQ1.

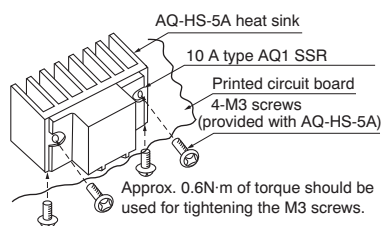

5. Others

1) If an SSR is used in close proximity to another SSR or heat-generating device, its ambient temperature may exceed the allowable level. Carefully plan SSR layout and ventilation.

2) Soldering to SSR terminals should be completed within 5 seconds at 260°C 500°F.

3) Terminal connections should be made by referring to the associated wiring diagram.

4) For higher reliability, check device quality under actual operating conditions.

6. Transportation and storage

1) Extreme vibration during transport will warp the lead or damage the relay.

Handle the outer and inner boxes with care.

2) Storage under extreme conditions will cause soldering degradation, external appearance defects, and deterioration of the characteristics. The following storage conditions are recommended:

- Temperature: 5 to 30°C 41 to 86°F
- Humidity: Less than 60% R.H.
- Atmosphere: No harmful gasses such as sulfurous acid gas, minimal dust.

For Cautions for Use, see Page 319.



Please contact us about TUV certified products.

Panasonic

ideas for life

2A and 3A space saving PC board terminal type

AQ8 RELAYS

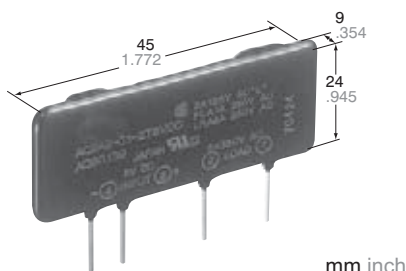

mm inch

FEATURES

1. Slim with 9 mm .354 inch thickness
The thin type (45 mm long × 24 mm high × 9 mm wide) (1.772×.945×.354 inch) permits high density mounting.

2. Excellent in noise resistance

Since the input and output are insulated by the phototriac coupler, the noise on the output side is not fed back to the input side.

3. Snubber circuit integrated

The snubber circuit is integrated to prevent malfunction caused by the rapid rise of the voltage on the output side, such as inductive load and noise.

4. Zero-cross and Non zero-cross types are available.

The zero-cross type generates minimal noise by suppressing occurrence of radio frequency interference (RFI) and electro-magnetic interference (EMI).

The non zero-cross type features a short operation time which permits phase control.

5. High dielectric strength: 3,000 V AC (between input and output)

6. Two kinds of terminals distance are available. (5.08 mm and 7.62 mm) (.200 and .300 inch)

7. High reliability, long life and maintenance-free

TYPICAL APPLICATIONS

Most suitable as drivers for small size AC motors, solenoids, solenoid valves and so on.

1. Copying equipment
2. Air conditioners
3. Industrial equipment such as NC machines, sequencers, robots and so on

TYPES

1. Zero-cross type

Input terminals distance	Max. load current	Load voltage	Input voltage	Part No.
5.08 mm .200 inch type	2 A	75 to 125 V AC	5 V DC	AQ2A1-C1-ZT5VDC
			12 V DC	AQ2A1-C1-ZT12VDC
			24 V DC	AQ2A1-C1-ZT24VDC
		75 to 250 V AC	5 V DC	AQ2A2-C1-ZT5VDC
			12 V DC	AQ2A2-C1-ZT12VDC
			24 V DC	AQ2A2-C1-ZT24VDC
	3 A	75 to 125 V AC	5 V DC	AQ3A1-C1-ZT5VDC
			12 V DC	AQ3A1-C1-ZT12VDC
			24 V DC	AQ3A1-C1-ZT24VDC
		75 to 250 V AC	5 V DC	AQ3A2-C1-ZT5VDC
			12 V DC	AQ3A2-C1-ZT12VDC
			24 V DC	AQ3A2-C1-ZT24VDC
7.62 mm .300 inch type	2 A	75 to 125 V AC	5 V DC	AQ2A1-C2-ZT5VDC
			12 V DC	AQ2A1-C2-ZT12VDC
			24 V DC	AQ2A1-C2-ZT24VDC
		75 to 250 V AC	5 V DC	AQ2A2-C2-ZT5VDC
			12 V DC	AQ2A2-C2-ZT12VDC
			24 V DC	AQ2A2-C2-ZT24VDC
	3 A	75 to 125 V AC	5 V DC	AQ3A1-C2-ZT5VDC
			12 V DC	AQ3A1-C2-ZT12VDC
			24 V DC	AQ3A1-C2-ZT24VDC
		75 to 250 V AC	5 V DC	AQ3A2-C2-ZT5VDC
			12 V DC	AQ3A2-C2-ZT12VDC
			24 V DC	AQ3A2-C2-ZT24VDC

2. Non zero-cross type

Input terminals distance	Max. load current	Load voltage	Input voltage	Part No.
5.08 mm .200 inch type	2 A	75 to 125 V AC	5 V DC	AQ2A1-C1-T5VDC
			12 V DC	AQ2A1-C1-T12VDC
			24 V DC	AQ2A1-C1-T24VDC
		75 to 250 V AC	5 V DC	AQ2A2-C1-T5VDC
			12 V DC	AQ2A2-C1-T12VDC
			24 V DC	AQ2A2-C1-T24VDC
	3 A	75 to 125 V AC	5 V DC	AQ3A1-C1-T5VDC
			12 V DC	AQ3A1-C1-T12VDC
			24 V DC	AQ3A1-C1-T24VDC
		75 to 250 V AC	5 V DC	AQ3A2-C1-T5VDC
			12 V DC	AQ3A2-C1-T12VDC
			24 V DC	AQ3A2-C1-T24VDC
7.62 mm .300 inch type	2 A	75 to 125 V AC	5 V DC	AQ2A1-C2-T5VDC
			12 V DC	AQ2A1-C2-T12VDC
			24 V DC	AQ2A1-C2-T24VDC
		75 to 250 V AC	5 V DC	AQ2A2-C2-T5VDC
			12 V DC	AQ2A2-C2-T12VDC
			24 V DC	AQ2A2-C2-T24VDC
	3 A	75 to 125 V AC	5 V DC	AQ3A1-C2-T5VDC
			12 V DC	AQ3A1-C2-T12VDC
			24 V DC	AQ3A1-C2-T24VDC
		75 to 250 V AC	5 V DC	AQ3A2-C2-T5VDC
			12 V DC	AQ3A2-C2-T12VDC
			24 V DC	AQ3A2-C2-T24VDC

Remark: Standard packing Carton: 20 pcs.; Case: 200 pcs.

AQ8

RATINGS

1. Rating (Ambient temperature: 20°C, 68°F; Voltage ripple on the input side: 1% or less)

1) Zero-cross type

• 2 A type

Item		Part No.	AQ2A1-C1-ZT5VDC AQ2A1-C2-ZT5VDC	AQ2A1-C1-ZT12VDC AQ2A1-C2-ZT12VDC	AQ2A1-C1-ZT24VDC AQ2A1-C2-ZT24VDC	AQ2A2-C1-ZT5VDC AQ2A2-C2-ZT5VDC	AQ2A2-C1-ZT12VDC AQ2A2-C2-ZT12VDC	AQ2A2-C1-ZT24VDC AQ2A2-C2-ZT24VDC	Remarks
Input side	Control voltage	5 V DC (4 to 6V)	12 V DC (9.6 to 14.4V)	24 V DC (21.6 to 26.4V)	5 V DC (4 to 6V)	12 V DC (9.6 to 14.4V)	24 V DC (21.6 to 26.4V)	The parenthesized values represent the allowable voltage ranges	
	Input impedance	Approx. 0.18 k Ω	Approx. 0.55 k Ω	Approx. 1.4 k Ω	Approx. 0.18 k Ω	Approx. 0.55 k Ω	Approx. 1.4 k Ω		
	Drop-out voltage	min. 0.5 V	min. 1.2 V	min. 2.4 V	min. 0.5 V	min. 1.2 V	min. 2.4 V		
Load side	Max. load current	2 A*1						At ambient temperature of 30°C or less	
	Load voltage	75 to 125 V AC			75 to 250 V AC				
	Frequency	45 to 65 Hz							
	Repetitive peak OFF voltage	400 V			600 V				
	Non-repetitive surge current	30 A*2						In one cycle at 60 Hz	
	Max. "OFF-state" leakage current	2.5 mA/100 V applied			5 mA/200 V applied				
	Max. "ON-state" voltage drop	1.6 V						at max. carrying current	
	Min. load current	25 mA*3			50 mA*3				
	OFF state dV/dt	50 V/μs						At ambient temperature of 80°C	

• 3 A type

Item		Part No.	AQ3A1-C1-ZT5VDC AQ3A1-C2-ZT5VDC	AQ3A1-C1-ZT12VDC AQ3A1-C2-ZT12VDC	AQ3A1-C1-ZT24VDC AQ3A1-C2-ZT24VDC	AQ3A2-C1-ZT5VDC AQ3A2-C2-ZT5VDC	AQ3A2-C1-ZT12VDC AQ3A2-C2-ZT12VDC	AQ3A2-C1-ZT24VDC AQ3A2-C2-ZT24VDC	Remarks
Input side	Control voltage	5 V DC (4 to 6V)	12 V DC (9.6 to 14.4V)	24 V DC (21.6 to 26.4V)	5 V DC (4 to 6V)	12 V DC (9.6 to 14.4V)	24 V DC (21.6 to 26.4V)	The parenthesized values represent the allowable voltage ranges	
	Input impedance	Approx. 0.18 k Ω	Approx. 0.55 k Ω	Approx. 1.4 k Ω	Approx. 0.18 k Ω	Approx. 0.55 k Ω	Approx. 1.4 k Ω		
	Drop-out voltage	min. 0.5 V	min. 1.2 V	min. 2.4 V	min. 0.5 V	min. 1.2 V	min. 2.4 V		
Load side	Max. load current	3 A*1						At ambient temperature of 30°C or less	
	Load voltage	75 to 125 V AC			75 to 250 V AC				
	Frequency	45 to 65 Hz							
	Repetitive peak OFF voltage	400 V			600 V				
	Non-repetitive surge current	80 A*2						In one cycle at 60 Hz	
	Max. "OFF-state" leakage current	2.5 mA/100 V applied			5 mA/200 V applied				
	Max. "ON-state" voltage drop	1.6 V						at max. carrying current	
	Min. load current	25 mA*3			50 mA*3				
	OFF state dV/dt	50 V/μs						At ambient temperature of 80°C	

Notes: *1) Refer REFERENCE DATA 1, characteristics of load current vs. ambient temperature.

*2) Refer to REFERENCE DATA 2, characteristics of non-repetitive surge current vs. carrying time.

*3) When the load current is less than the min. load current, refer to "NOTES (page 352)".

2) Non zero-cross type

• 2 A type

Item		Part No.	AQ2A1-C1-T5VDC AQ2A1-C2-T5VDC	AQ2A1-C1-T12VDC AQ2A1-C2-T12VDC	AQ2A1-C1-T24VDC AQ2A1-C2-T24VDC	AQ2A2-C1-T5VDC AQ2A2-C2-T5VDC	AQ2A2-C1-T12VDC AQ2A2-C2-T12VDC	AQ2A2-C1-T24VDC AQ2A2-C2-T24VDC	Remarks
Input side	Control voltage	5 V DC (4 to 6V)	12 V DC (9.6 to 14.4V)	24 V DC (21.6 to 26.4V)	5 V DC (4 to 6V)	12 V DC (9.6 to 14.4V)	24 V DC (21.6 to 26.4V)		The parenthesized values represent the allowable voltage ranges
	Input impedance	Approx. 0.3 k Ω	Approx. 0.8 k Ω	Approx. 1.8 k Ω	Approx. 0.3 k Ω	Approx. 0.8 k Ω	Approx. 1.8 k Ω		
	Drop-out voltage	min. 0.5 V	min. 1.2 V	min. 2.4 V	min. 0.5 V	min. 1.2 V	min. 2.4 V		
Load side	Max. load current	2 A*1							At ambient temperature of 30°C or less
	Load voltage	75 to 125 V AC			75 to 250 V AC				
	Frequency	45 to 65 Hz							
	Repetitive peak OFF voltage	400 V			600 V				
	Non-repetitive surge current	30 A*2							In one cycle at 60 Hz
	Max. "OFF-state" leakage current	2.5 mA/100 V applied			5 mA/200 V applied				
	Max. "ON-state" voltage drop	1.6 V							at max. carrying current
	Min. load current	25 mA*3			50 mA*3				
	OFF state dV/dt	50 V/ μ s							At ambient temperature of 80°C

• 3 A type

Item		Part No.	AQ3A1-C1-T5VDC AQ3A1-C2-T5VDC	AQ3A1-C1-T12VDC AQ3A1-C2-T12VDC	AQ3A1-C1-T24VDC AQ3A1-C2-T24VDC	AQ3A2-C1-T5VDC AQ3A2-C2-T5VDC	AQ3A2-C1-T12VDC AQ3A2-C2-T12VDC	AQ3A2-C1-T24VDC AQ3A2-C2-T24VDC	Remarks
Input side	Control voltage	5 V DC (4 to 6V)	12 V DC (9.6 to 14.4V)	24 V DC (21.6 to 26.4V)	5 V DC (4 to 6V)	12 V DC (9.6 to 14.4V)	24 V DC (21.6 to 26.4V)		The parenthesized values represent the allowable voltage ranges
	Input impedance	Approx. 0.3 k Ω	Approx. 0.8 k Ω	Approx. 1.8 k Ω	Approx. 0.3 k Ω	Approx. 0.8 k Ω	Approx. 1.8 k Ω		
	Drop-out voltage	min. 0.5 V	min. 1.2 V	min. 2.4 V	min. 0.5 V	min. 1.2 V	min. 2.4 V		
Load side	Max. load current	3 A*1							At ambient temperature of 30°C or less
	Load voltage	75 to 125 V AC			75 to 250 V AC				
	Frequency	45 to 65 Hz							
	Repetitive peak OFF voltage	400 V			600 V				
	Non-repetitive surge current	80 A*2							In one cycle at 60 Hz
	Max. "OFF-state" leakage current	2.5 mA/100 V applied			5 mA/200 V applied				
	Max. "ON-state" voltage drop	1.6 V							at max. carrying current
	Min. load current	25 mA*3			50 mA*3				
	OFF state dV/dt	50 V/ μ s							At ambient temperature of 80°C

Notes: *1) Refer REFERENCE DATA 1, characteristics of load current vs. ambient temperature.

*2) Refer to REFERENCE DATA 2, characteristics of non-repetitive surge current vs. carrying time.

*3) When the load current is less than the min. load current, refer to "NOTES (page 352)".

AQ8

2. Characteristics (Ambient temperature: 20°C 68°F; Input voltage ripple: 1% or less)

Item	Type	Zero-cross type	Non zero-cross type	Remarks
Operate time, max.		1/2 cycle of voltage sine wave + 1 ms	1 ms	
Release time, max.		1/2 cycle of voltage sine wave + 1 ms		
Insulation resistance, min.		10 ⁹ Ω between input and output		at 500 V DC
Breakdown voltage		3,000 V AC between input and output		For 1 minute
Vibration resistance	Functional	10 to 55 Hz at double amplitude of 3 mm		10 min. for X, Y, Z axis
	Destructive	10 to 55 Hz at double amplitude of 3 mm		1 hour for X, Y, Z axis
Shock resistance	Functional	Min. 980 m/s ² {100 G}		4 times each for X, Y, Z axis
	Destructive	Min. 980 m/s ² {100 G}		5 times each for X, Y, Z axis
Ambient temperature		-30°C to +80°C -22°F to +176°F		
Storage temperature		-30°C to +100°C -22°F to +212°F		
Operational method		Zero-cross (Turn ON and Turn OFF)	Non zero-cross turn ON, zero-cross turn OFF	

DIMENSIONS (mm inch)

Download [CAD Data](#) from our Web site.

(Common for zero-cross and non zero-cross types)

1. Input terminals distance 5.08 mm .200 inch

1) 2 A type

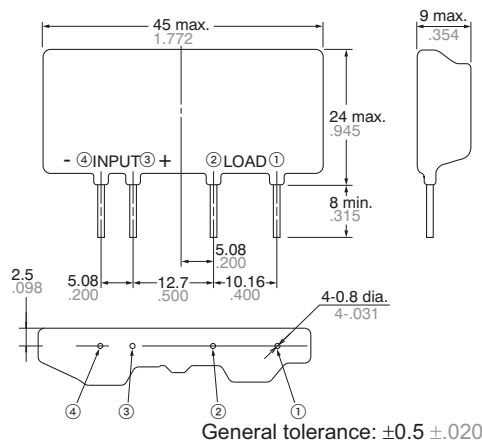
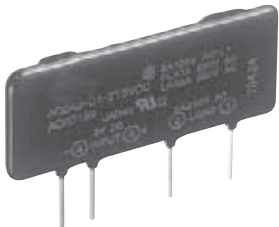
[CAD Data](#)

Mounting hole location (Bottom view)

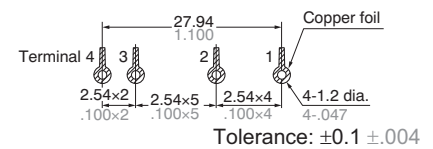

Schematic

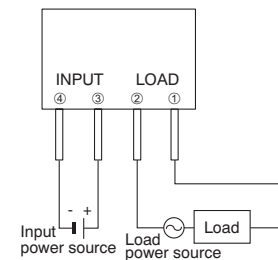

2) 3 A type

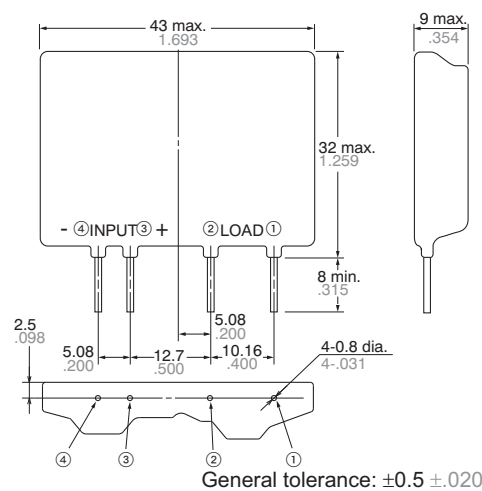
[CAD Data](#)

Mounting hole location (Bottom view)

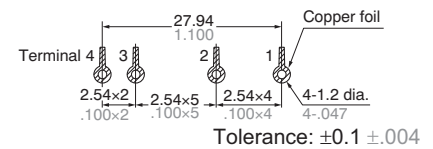

Schematic

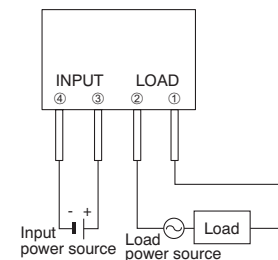

AQ8

mm inch

2. Input terminals distance 7.62 mm .300 inch

1) 2A type

CAD Data

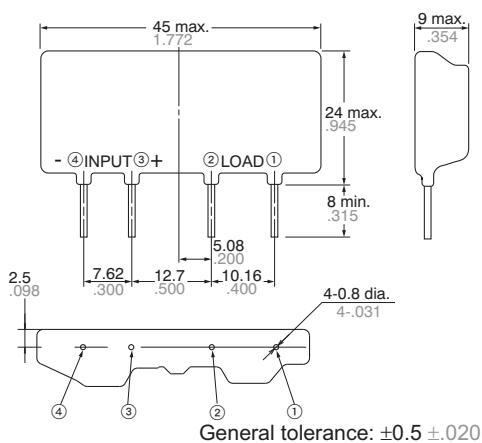
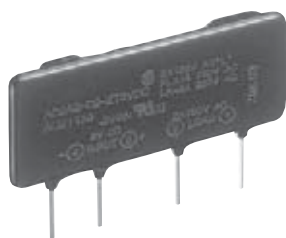

Mounting hole location (Bottom view)

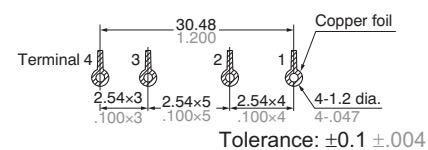

Schematic

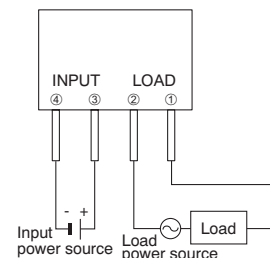

2) 3A type

CAD Data

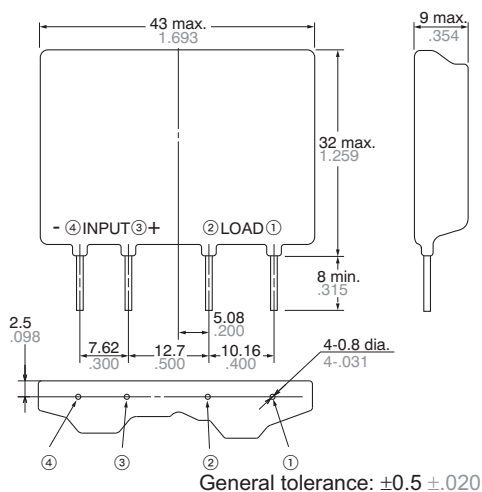

Mounting hole location (Bottom view)

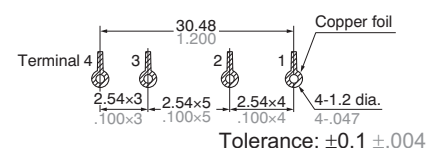

Schematic

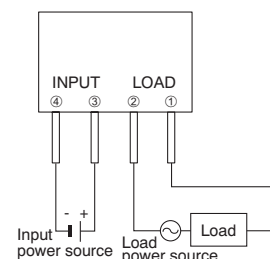

REFERENCE DATA

4. Characteristics of load current vs. ambient temperature

Conditions: Natural cooling

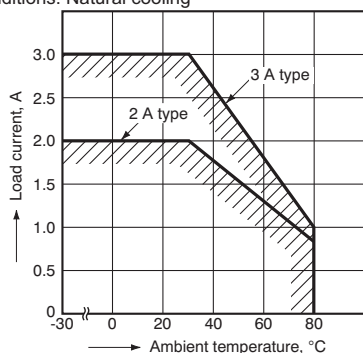

5. Characteristics of non-repetitive surge current vs. carrying time

(2 A type)

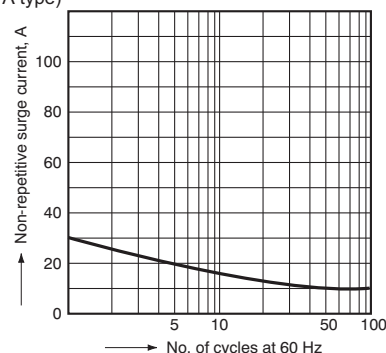

(3 A type)

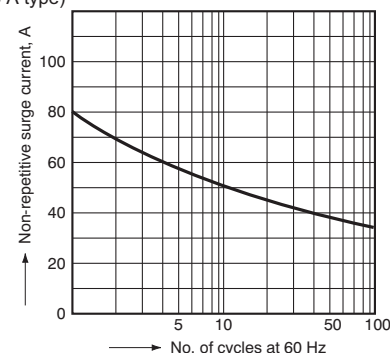

AQ8

6. Characteristics of input current vs. input voltage

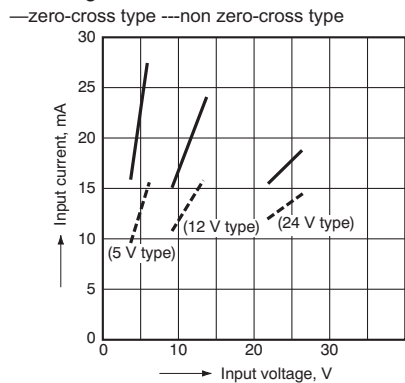

7. Characteristics of load current vs. ambient temperature for adjacent mounting

Conditions: Natural cooling
(2 A type)

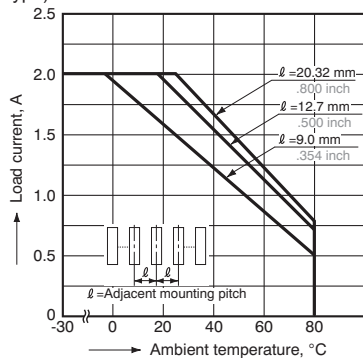

(3 A type)

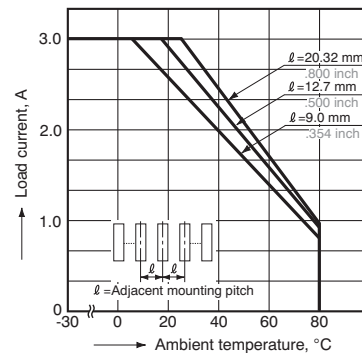

Approved standards list

Product name	File No.	Qualified ratings
AQ8	UL E95895	2A type: 2 A 125, 250 V AC 2 A 125 V AC (Tungsten) FLA 1 A, LRA 6 A 125, 250 V AC
	CSA LR26550	3A type: 3 A 125, 250 V AC 3 A 125 V AC (Tungsten) FLA 1.5 A, LRA 9 A 125, 250 V AC

NOTES

1. When used for the load less than rated

In case of the load current less than rated, malfunction may result from the residual voltage across the both ends of the load even if the solid state relay is turned off. Use a dummy resistor as a countermeasure.

The total of the current through the resistor and the load current must exceed the min. rated load current.

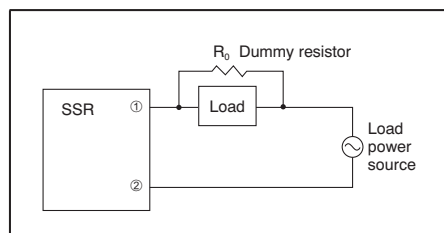

In case the dummy resistor is not used, keep in mind that the residual voltage becomes as follows:

Example:

For the inductive load by the 20 mA load current and the 200 V AC load voltage, the load impedance becomes 10 kΩ and $V_e/V = 14\%$ is estimated from the right above graph. Accordingly, the 28 V voltage remains across the both ends of the load when the solid state relay is turned off.

• Characteristics of residual voltage vs. load impedance

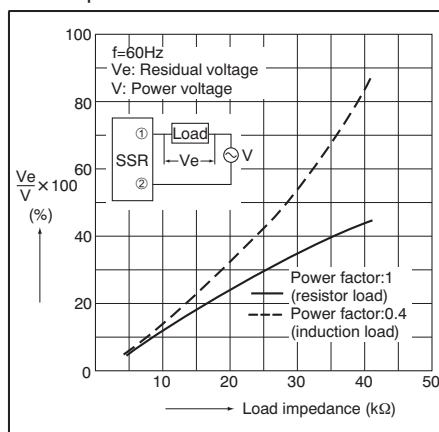

2. Solder the terminals within 5 seconds at 260°C 500°F.

3. When the terminal is bent

Care shall be taken neither to apply mechanical stresses to the mold area of the solid state relay nor to bend the terminal 45 degrees or more.

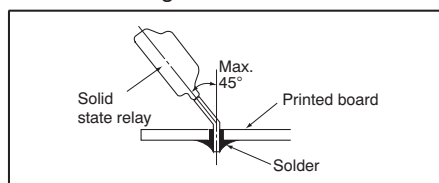

For Cautions for Use, see Page 319.

Panasonic
ideas for life

AC and DC Plug-in type

AQ-F RELAYS

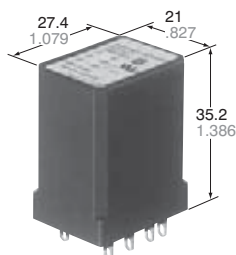

mm inch

FEATURES

- Suitable for high-capacity and high-frequency switching
- Same size, same terminal arrangement as HC relay
Sockets for HC relays are applicable
- Two load types available: DC output type (2 A, 3 A)
AC output type (2 A, 3 A)
- Wide range of input voltage: 3 V to 28 V

TYPICAL APPLICATIONS

Drive for small-sized motor, heater, solenoid and electromagnetic valves.

- NC machine
- Printing machine
- Machine tool
- Robot for industrial use
- Wrapping and packing machine

TYPES

	Type	Part No.
AC output	Zero-cross 2 A	AQF2A2-ZT3/28VDC
	Zero-cross 3 A	AQF3A2-ZT3/28VDC
DC output	2 A	AQF2AD1-3/28VDC
	3 A	AQF3AD1-3/28VDC

SPECIFICATIONS

Ratings (at 20°C 68°F, Input voltage ripple: 1% or less)

Item	Type	AC output		DC output		Remarks
		AQF2A2-ZT3/28VDC	AQF3A2-ZT3/28VDC	AQF2AD1-3/28VDC	AQF3AD1-3/28VDC	
Input side	Input voltage	3 to 28 V DC				
	Input impedance	Approx. 1.6 k Ω (3 to 28 V DC)				
	Drop-out voltage, min.	0.8 V DC				
Load side	Max. load current	2 A	3 A	2 A	3 A	See "REFERENCE DATA 1" on the following page
	Load voltage	75 to 250 V AC		3 to 60 V DC		
	Non-repetitive surge current	80 A		5 A	6 A	AC: In one cycle at 60 Hz DC: 1 s
	Max. "OFF-state" leakage current	5 mA		1 mA		AC: at 60 Hz 200 V DC: at 60 V
	Max. "ON-state" voltage drop	1.6 V				at max. carrying current
	Min. load current	50 mA		5 mA		

Characteristics (at 20°C 68°F, Input voltage ripple: 1% or less)

Item	Type	AC output		DC output		Remarks
		AQF2A2-ZT3/28 VDC	AQF3A2-ZT3/28 VDC	AQF2AD1-3/28 VDC	AQF3AD1-3/28 VDC	
Operate time max.		(1/2 cycle of voltage sine wave) + 1 ms		0.5 ms		
Release time, max.		(1/2 cycle of voltage sine wave) + 1 ms		2 ms		
Insulation resistance, min.		100 M Ω between input and output				Initial at 500 V DC
Breakdown voltage		2,000 Vrms between input and output				Initial for 1 min.
Vibration resistance	Functional	10 to 55 Hz double amplitude of 3 mm				10 min. for X, Y, Z axes
	Destructive	10 to 55 Hz double amplitude of 3 mm				1 hour for X, Y, Z axes
Shock resistance	Functional	Min. 980 m/s ² {100 G}				4 times each for X, Y, Z axes
	Destructive	Min. 980 m/s ² {100 G}				5 times each for X, Y, Z axes
Ambient temperature		-30°C to +80°C -22°F to +176°F				
Storage temperature		-30°C to +100°C -22°F to +212°F				
Operational method		Zero-cross (Turn-ON and Turn-OFF)		—		

AQ-F

OPERATING PRINCIPLE

Internal circuit
AC output type

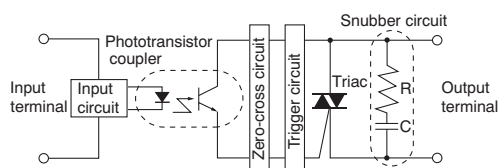

Waveform of input and output (Resistive load)

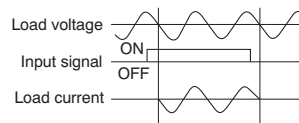

DC output type

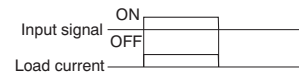
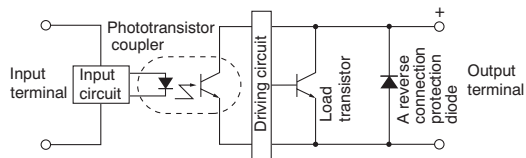

DIMENSIONS (mm inch)

Download [CAD Data](#) from our Web site.

[CAD Data](#)

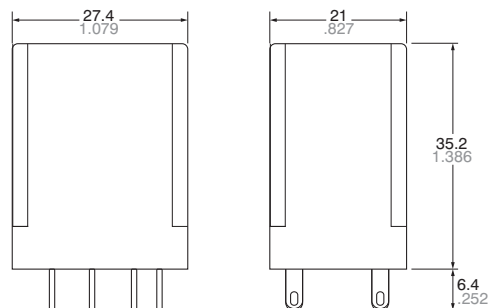

AQ-F SOLID STATE RELAY ACCESSORIES

Socket of HC relay is available for AQ-F solid state relay.

1. Socket for plug-in type

HC2 socket

[CAD Data](#)

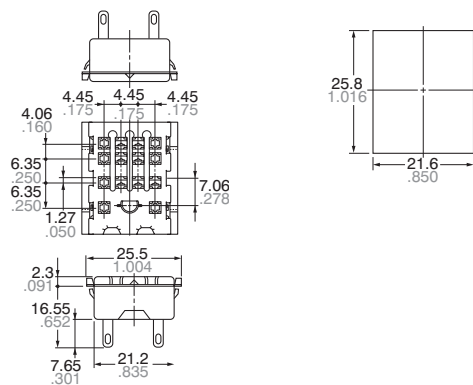
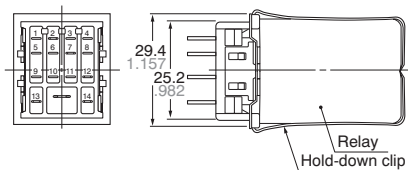

Tolerance: $\pm 0.1 \pm .004$

HC2-SS-K

Note: HC3-SS-K and HC4-SS-K can be also used.

2. Socket for PC board

HC2 socket for PC board

Tolerance: $\pm 0.1 \pm 0.04$

CAD Data



13.35

3. Wrapping socket

Standard wrapping socket

mm inch

CAD Data

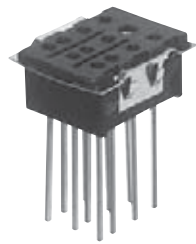

HC4-WS-K

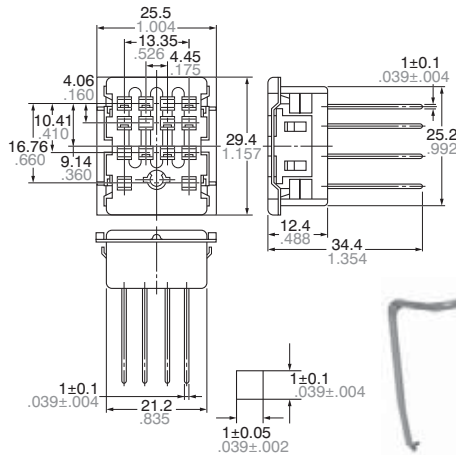

Wrapping socket with lock spring

CAD Data

HC4-WS-L

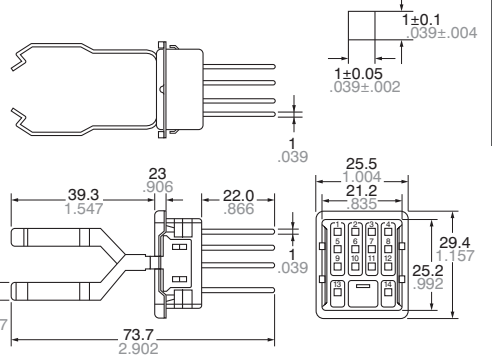
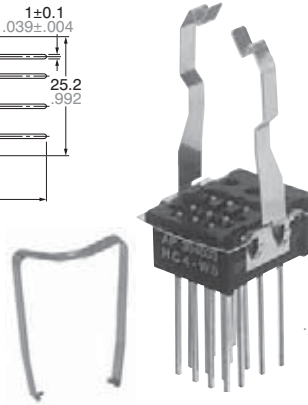

Solid State

4. DIN rail mounting socket

CAD Data



HC2-SFD-K

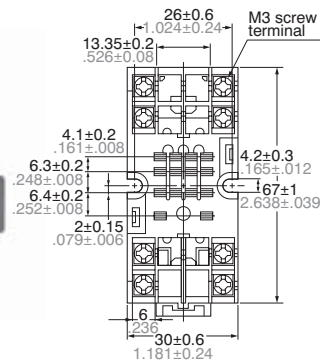

Schematic

Mounting dimension (Bottom view)

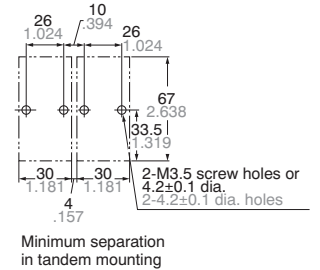
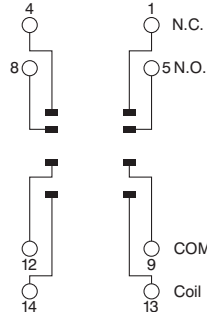
**5. DIN socket for HC2-vertical type**

CAD Data

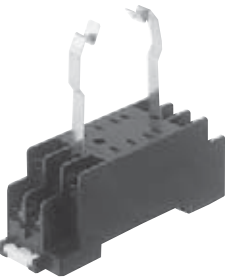

HC2-SFD-S

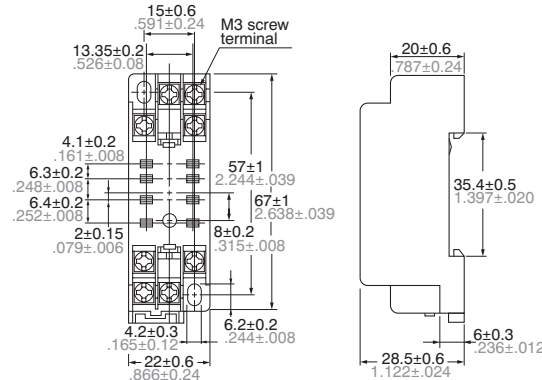

Schematic

Mounting dimension (Bottom view)

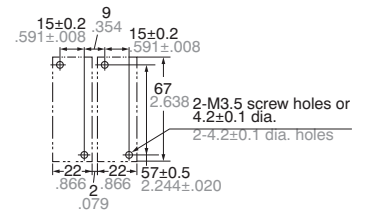
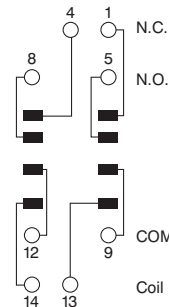

AQ-F

6. General socket

CAD Data



HC2-SF-K

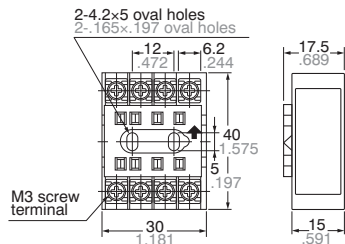

Schematic



Mounting dimension (Bottom view)

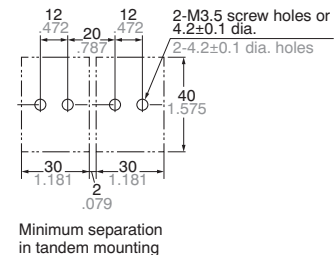

Mounting rail

CAD Data



AT8-DLA1

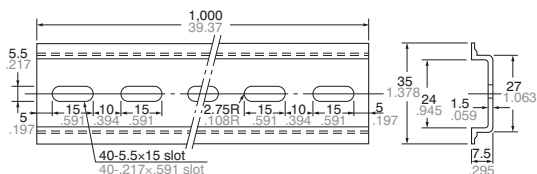

Fastening plate



ATA4806

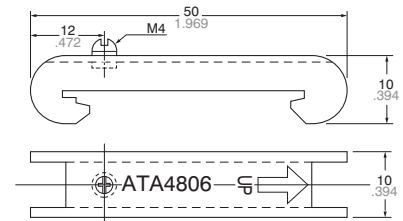

REFERENCE DATA

8. Load current vs. ambient temperature

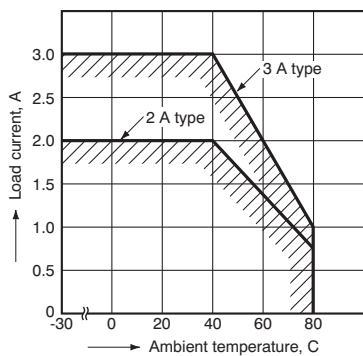

9-(1). Non-repetitive surge current vs. carrying time (AC output type)

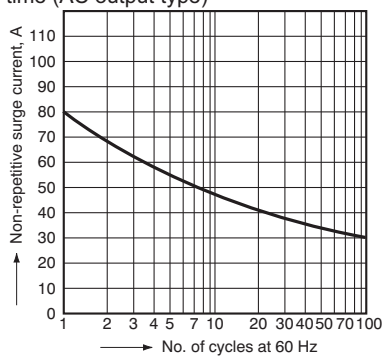

2-(2). Non-repetitive surge current vs. carrying time (DC output type)

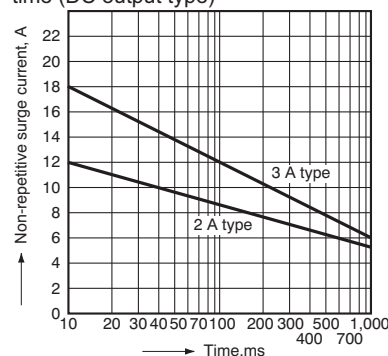

10. Input current vs. input voltage

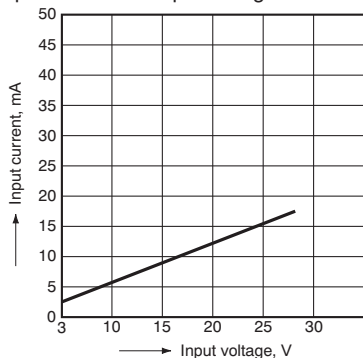

For Cautions for Use, see Page 319.

Panasonic

ideas for life

**Compact high capacity
(25A max)
Slim heat sink combined type
joining the lineup**

AQ-J RELAYS

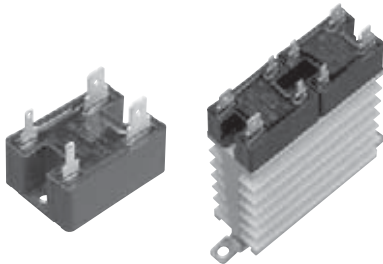

Slim heat sink combined type

FEATURES

- 1. Compact Size**
Approx 40% reduction in required space achieved in the footprint area compared with the previous model (AQ-R relay)
- 2. Built-in varistor**
- 3. Reverse input connection prevention function**
- 4. Labor Saving (tab terminal)**
- 5. Output arrangement 1a and 1a × 2 available in the heat sink combined type**

Note: * International standards are acquired for AQ-J SSR stand-alone, not applied to heat sink combined type.

TYPICAL APPLICATIONS

- 1. Kitchen appliances**
- 2. Vending machine**
- 3. Injection molding machine**
- 4. Packing machine**
- 5. Amusement machine**

Solid State

ORDERING INFORMATION

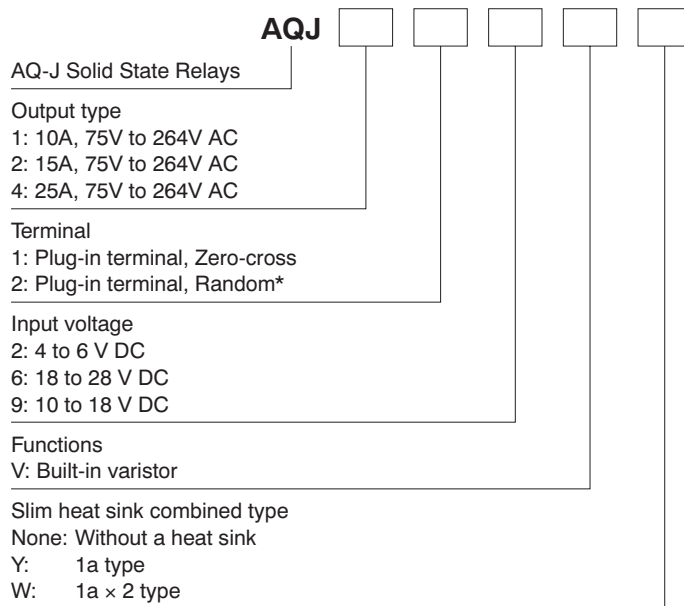

Note: * Random type is available by custom order.

TYPES

1. AQ-J Solid State Relays

Type	Load current	Load voltage	Input voltage	Part No.
Zero-cross*	10A	75V to 264V AC	4 to 6V DC	AQJ112V
			10 to 18V DC	AQJ119V
			18 to 28V DC	AQJ116V
	15A		4 to 6V DC	AQJ212V
			10 to 18V DC	AQJ219V
			18 to 28V DC	AQJ216V
	25A		4 to 6V DC	AQJ412V
			10 to 18V DC	AQJ419V
			18 to 28V DC	AQJ416V

Standard Packing; carton: 10 pcs., case: 200 pcs.
Note: * Random type also available. Please inquire.

AQ-J

2. AQ-J SSR Slim Heat Sink Combined Type

Output configuration	Type	Load current	Load voltage	Input voltage	Part No.		
1a	Zero-cross*	10A	75V to 264V AC	4 to 6V DC	AQJ112VY		
				10 to 18V DC	AQJ119VY		
				18 to 28V DC	AQJ116VY		
		20A		4 to 6V DC	AQJ412VY		
				10 to 18V DC	AQJ419VY		
				18 to 28V DC	AQJ416VY		
1a × 2		Zero-cross*		10A (per 1a)	75V to 264V AC	4 to 6V DC	AQJ112VW
						10 to 18V DC	AQJ119VW
						18 to 28V DC	AQJ116VW
				15A (per 1a)		4 to 6V DC	AQJ412VW
						10 to 18V DC	AQJ419VW
						18 to 28V DC	AQJ416VW

Standard Packing; no carton, case: 10 pcs.

Note: * Random type also available. Please inquire.

3. Accessories

Type	Part No.	Packaged quantity
DIN rail mounting plate	AQP-DPJ	5 in a carton, 50 in a case
Slim heat sink (28mm wide) (Mountable on a DIN rail)	AQP-HS-SJ10A	No carton, 10 in a case
Slim heat sink (45mm wide) (Mountable on a DIN rail)	AQP-HS-SJ20A	No carton, 8 in a case
Standard heat sink (10A and 15A)	AQP-HS-J10A	5 in a carton, 20 in a case
Standard heat sink (25A only)	AQP-HS-J25A	No carton, 5 in a case

SPECIFICATIONS

1. Ratings (Test sample: AQ-J stand-alone, Measurement condition: at 20°C 68°F, input ripple: 1% or less)

1) Input side

Item	Part No.	AQJ112V AQJ212V AQJ412V	AQJ119V AQJ219V AQJ419V	AQJ116V AQJ216V AQJ416V
Rated voltage		5V DC	12V DC	24V DC
Input voltage		4 to 6V DC	10 to 18V DC	18 to 28V DC
Input impedance		Approx. 260Ω	Approx. 800Ω	Approx. 1.6kΩ
Drop-out voltage		Min. 1V DC		

2) Output side

Item	Part No.	AQJ112V AQJ119V AQJ116V	AQJ212V AQJ219V AQJ216V	AQJ412V AQJ419V AQJ416V
Max. load current		10A	15A	25A
Load voltage		75 to 264V AC		
Frequency		45Hz to 65Hz		
Non-repetitive surge current		100A	150A	250A
Max. "OFF-state" leakage current		Max. 5mA		
Max. "ON-state" voltage drop		Max. 1.6V		
Min. load current*		50mA		

Note: * When the load current is less than the rated minimum load current, please refer to Cautions for Use, page 319.

2. Ratings (Test sample: AQ-J slim heat sink combined type, Measurement condition: at 20°C 68°F, input ripple: 1% or less)

1) Input side

Item	Part No.	AQJ112V(Y-W) AQJ412V(Y-W)	AQJ119V(Y-W) AQJ419V(Y-W)	AQJ116V(Y-W) AQJ416V(Y-W)
Rated voltage		5V DC	12V DC	24V DC
Input voltage		4 to 6V DC	10 to 18V DC	18 to 28V DC
Input impedance		Approx. 260Ω	Approx. 800Ω	Approx. 1.6kΩ
Drop-out voltage		Min. 1V DC		

2) Output side

Item	Part No.	AQJ112VY AQJ119VY AQJ116VY	AQJ412VY AQJ419VY AQJ416VY	AQJ112VW AQJ119VW AQJ116VW	AQJ412VW AQJ419VW AQJ416VW
Output arrangement		1a		1a × 2	
Max. load current*1		10A	20A	10A	15A
Load voltage		75 to 264V AC			
Frequency		45Hz to 65Hz			
Non-repetitive surge current		100A	250A	100A	250A
Max. "OFF-state" leakage current		Max. 5mA			
Max. "ON-state" voltage drop		Max. 1.6V			
Min. load current*2		50mA			

Notes: *1 Please refer to REFERENCE DATA, "1. Load current vs. ambient temperature" below.

*2 When the load current is less than the rated minimum load current, please refer to Cautions for Use, page 319.

3. Characteristics (Measurement condition: at 20°C 68°F, input ripple: 1% or less)

Item	Characteristics	Remarks
Operate time, max.	(1/2 cycle of voltage sine wave) + 1ms	
Release time, max.	(1/2 cycle of voltage sine wave) + 1ms	
Insulation resistance, min.	100MΩ between input to output to case	Using 500 V DC megger
Breakdown voltage	3,000 Vrms between input and output	for 1min.
	2,500 Vrms between input, output and case	
Vibration resistance	SSR stand-alone: 10 to 55Hz, double amplitude of 1.5mm Slim heat sink combined type: 10 to 55Hz, double amplitude of 0.75mm	X, Y, Z axes
Shock resistance	SSR stand-alone: Min. 980m/s ² Slim heat sink combined type: Min. 197m/s ²	X, Y, Z axes
Ambient temperature	-30 to +80°C -22 to +176°F	Non-condensing at low temperatures
Storage temperature	-30 to +100°C -22 to +212°F	
Operational method	Zero-cross (Turn ON and Turn OFF)	

REFERENCE DATA**(1) AQ-J Solid State Relays****1. Load current vs. ambient temperature Use load current within range specified in the figure below**

Tested condition:

1) If attached to a heat sink, use a heat conductive compound (Ex. Toshiba silicone YG6111 or TSK5303) of similar coating to improve cooling

2) Without external heat sink

If the mounting surface is not metallic and a heat sink is not used, expose the bottom surface and plate surface to improve heat dissipation.

3) The current value is per 1a.

(1) 10 A type (when using heat sink or iron plate)

(2)-1. 15 A type (when using iron plate)

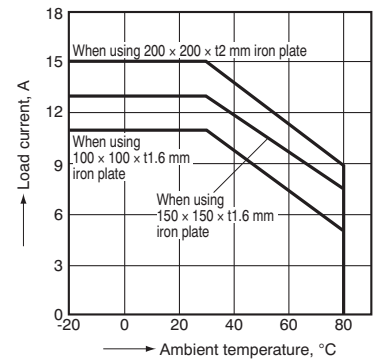
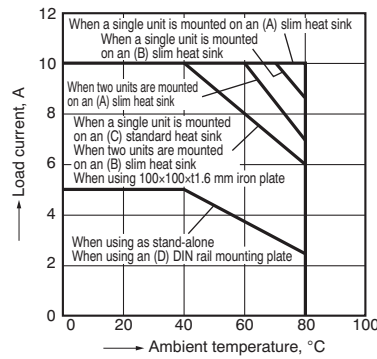

(2)-2. 15 A type (when using a heat sink)

(3)-1. 25 A type (when using iron plate)

(3)-2. 25 A type (when using a heat sink)

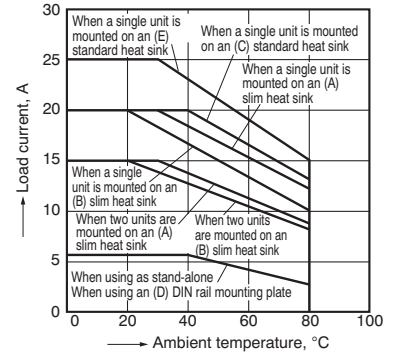
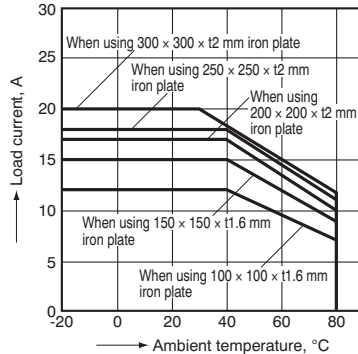
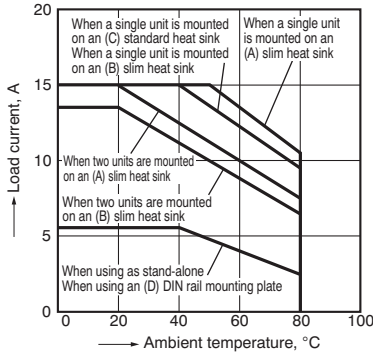
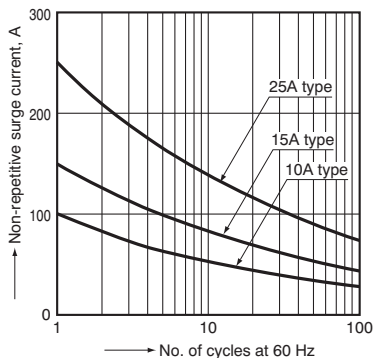
**2. Non-repetitive surge current vs. carrying time****3. Input current vs. input voltage characteristics**

(10A, 15A and 25A common)

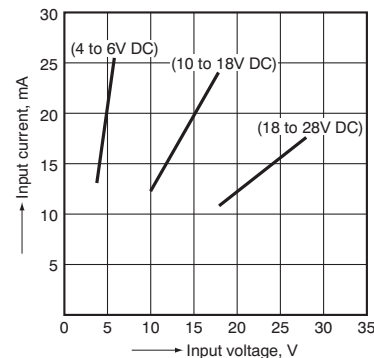

(A) slim heat sink	AQP-HS-SJ20A
(B) slim heat sink	AQP-HS-SJ10A
(C) standard heat sink	AQP-HS-J10A
(D) DIN rail mounting plate	AQP-DPJ
(E) standard heat sink	AQP-HS-J25A

AQ-J

(2) AQ-J SSR Slim Heat Sink Combined Type

1. Load current vs. ambient temperature Use load current within range specified in the figure below

(1) Output arrangement: 1a

(2) Output arrangement: 1a × 2

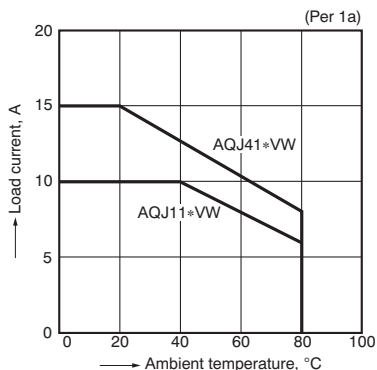
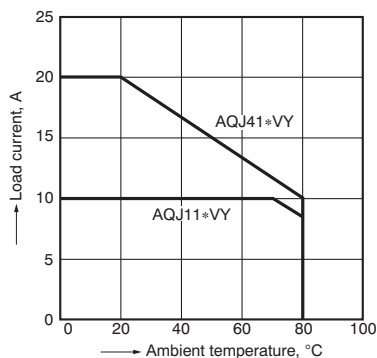

Note:
When two contacts are operated simultaneously.
In the case of a single-contact operation, the rating of
(1) AQJ11*VY, AQJ41*VY applies.

2. Surge current vs. carrying time

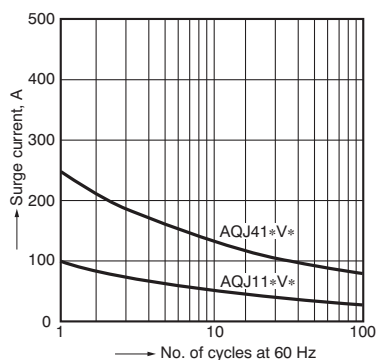

3. Input current vs. input voltage characteristics

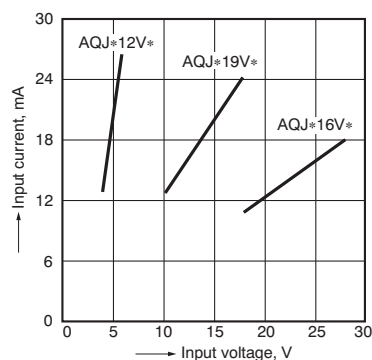

DIMENSIONS (mm inch)

Download **CAD Data** from our Web site.

1. AQ-J Stand Alone

CAD Data

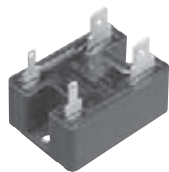

External dimensions

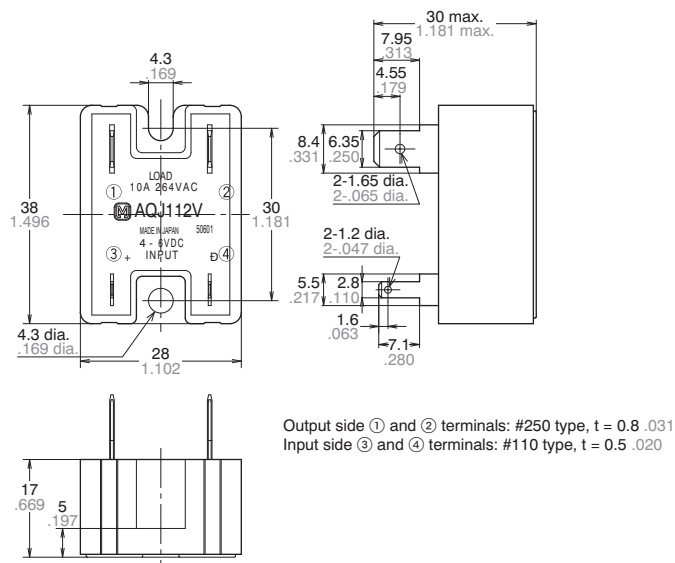

Output side ① and ② terminals: #250 type, t = 0.8 .031
Input side ③ and ④ terminals: #110 type, t = 0.5 .020

Schematic

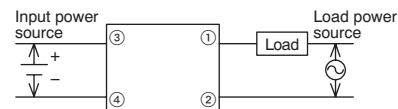

Mounting dimensions

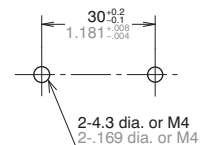

2.-(1) Slim Heat Sink Combined Type Output Arrangement: 1a

CAD Data

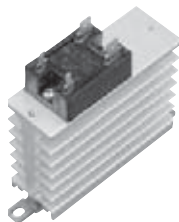

External dimensions

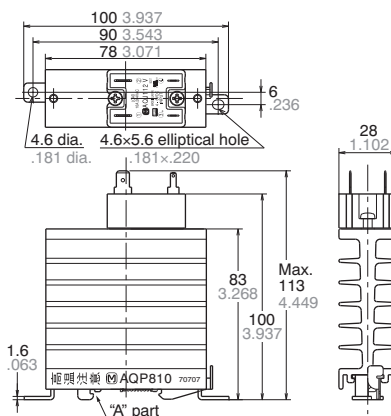

Note: When using on a DIN rail, please install so that the "A" part is on top.

Schematic

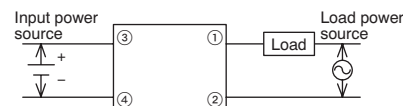

Mounting dimensions (Top view)

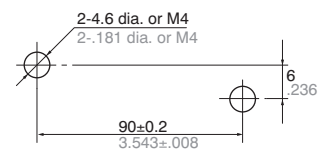

2.-(2) Slim Heat Sink Combined Type Output Arrangement: 1a × 2

CAD Data

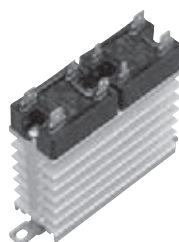

External dimensions

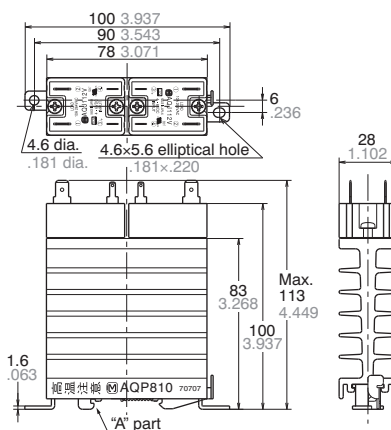

Note: When using on a DIN rail, please install so that the "A" part is on top.

Schematic

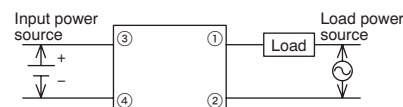

Note: Use caution for AQ-J terminal numbers.

Mounting dimensions (Top view)

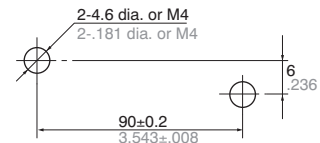

AQ-J

ACCESSORIES

AQP-HS-SJ10A Slim Heat Sink

CAD Data



Note: When using on a DIN rail, please install so that the "A" part is on top.

External dimensions

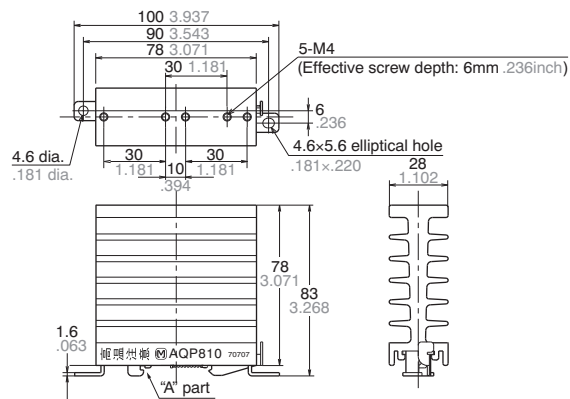

Mounting dimensions (Top view)

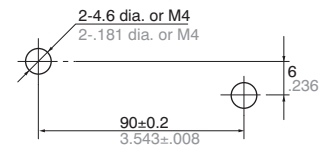

AQP-HS-SJ20A Slim Heat Sink

CAD Data

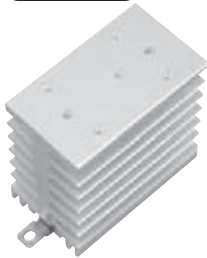

Note: When using on a DIN rail, please install so that the "A" part is on top.

External dimensions

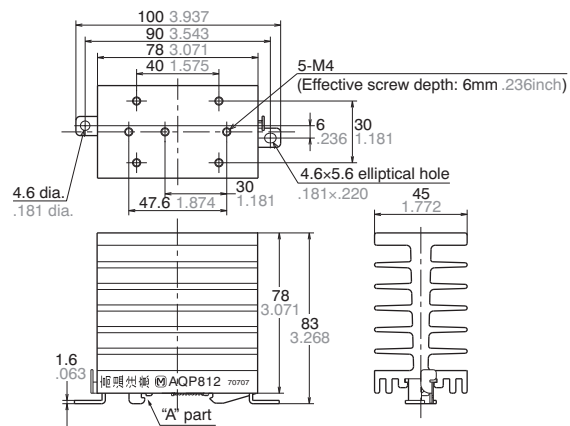

Mounting dimensions (Top view)

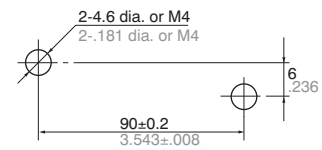
AQP-HS-J10A Standard Heat Sink
(for 10A and 15A types)

CAD Data

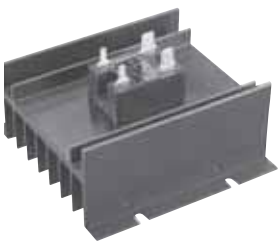

External dimensions

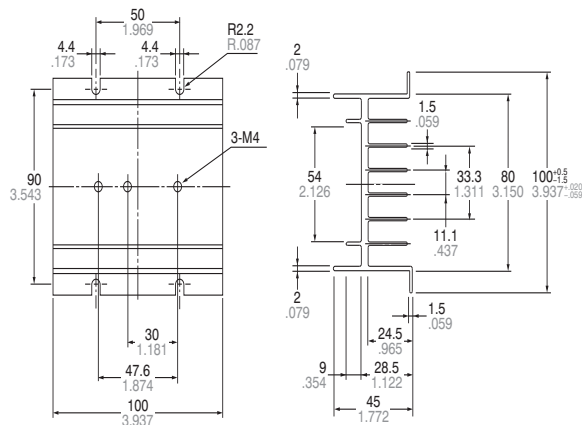

Mounting dimensions

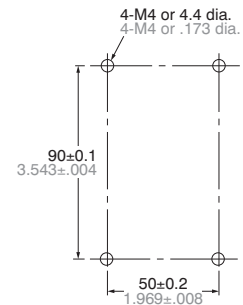

AQP-HS-J25A Standard Heat Sink (for 25A type)

CAD Data

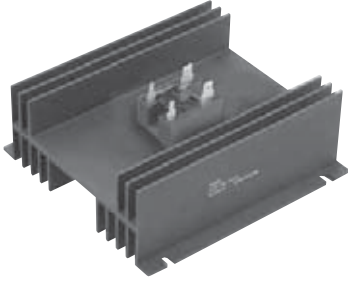

External dimensions

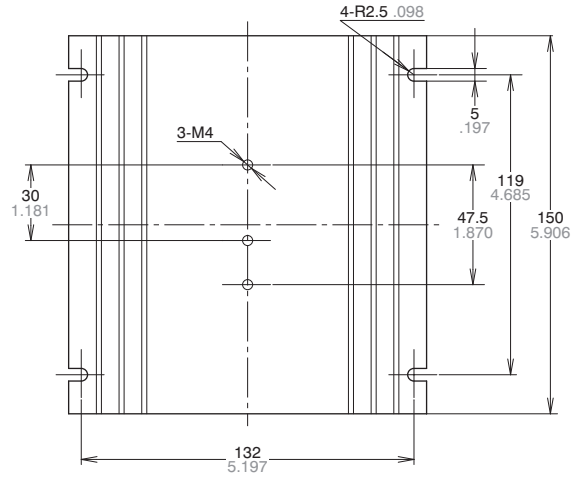

Mounting dimensions

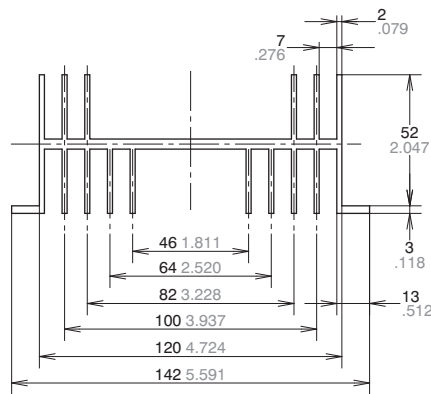
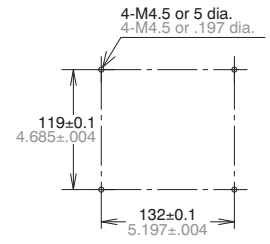

AQP-DPJ DIN Rail Mounting Plate

CAD Data



External dimensions

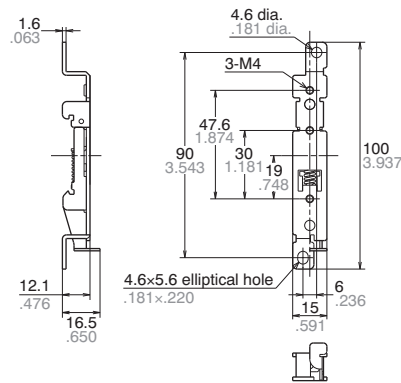

For Cautions for Use, see page 319.

Panasonic

ideas for life

Load current 15 to 40A
Small Screw Terminal SSR

AQ-A RELAYS



FEATURES

1. Compact Size

W 40 × L 58 × H 25.5 mm

W 1.575 × L 2.283 × H 1.004 inch

2. With terminal cover for safety (output side only).

* Cover on input side available as option.

3. Mounting pitch 47.5 mm 1.870 inch

4. Built in varistor for excellent surge absorption

5. With LED indication for operation status verification

TYPICAL APPLICATIONS

Heater control

• Business use:

Cooking machine

Vending machine

Freezer

Refrigerator

• Industrial use:

Molding machine

Temperature controlled bath

Printing machine

Packing machine

ORDERING INFORMATION

AQA

Output type

2: 15A, 75V to 250V AC

4: 25A, 75V to 250V AC

6: 40A, 75V to 250V AC

Terminal, Type

1: Screw terminal, Zero-cross

2: Screw terminal, Random*

Input voltage

1: 4 to 32 V DC

Functions

VL: Built-in varistor and LED indication

* Random type is available by custom order.

TYPES

1. AQ-A Solid State Relays

Type	Load current	Load voltage	Input voltage	Part No.
Zero-cross	15A	75V to 250V AC	4 to 32V DC	AQA211VL
	25A			AQA411VL
	40A			AQA611VL

Standard Packing; carton: 2 pcs., case: 60 pcs.

Note: Random type also available. Please inquire.

2. Accessories

Type	Part No.	Packaged quantity
Standard heat sink (15A)	AQP-HS-J10A	5 in a carton, 20 in a case
Standard heat sink (25A)	AQP-HS-30/40A	5 in a carton, 20 in a case
Standard heat sink (40A)	AQP-HS-J25A	No carton, 5 in a case
Slim heat sink (45mm wide) (Mountable on a DIN rail)	AQP-HS-SJ20A	No carton, 8 in a case
DIN rail mounting plate	AQP-DPJ	5 in a bag, 50 in a case
Terminal cover	AQA801	—

RATING

1. Ratings (Measurement condition: at 20°C 68°F, Input ripple: 1% or less)

Item	Part No.	AQA211VL	AQA411VL	AQA611VL	Remarks
Input side	Input voltage	4 to 32V DC			
	Input current	Max. 20mA			
	Drop-out voltage	Min. 1V			
Output side	Max. load current	15A	25A	40A	
	Load voltage	75 to 250V AC			
	Frequency	45 to 65Hz			
	Non-repetitive surge current	150A	250A	400A	In one cycle at 60Hz
	"OFF-state" leakage current	Max. 10mA			at 60Hz
	"ON-state" voltage drop	Min. 1.6V			at Max. carrying current
	Min. load current*	100mA			

Note: * When the load current is less than the rated minimum load current, please refer to Cautions for Use, page 319..

2. Characteristics (Measurement condition: at 20°C 68°F, Input ripple: 1% or less)

Item	AQA211VL	AQA411VL	AQA611VL	Remarks
Operate time	Max. 1/2 cycle of voltage sine wave + 1ms			
Release time	Max. 1/2 cycle of voltage sine wave + 1ms			
Insulation resistance	Min. 100MΩ between input and output			at 500 V DC
Breakdown voltage	4,000 Vrms between input and output 2,500 Vrms between input, output and case			for 1min.
Vibration resistance (Functional)	10 to 55Hz double amplitude of 1.5mm			X, Y, Z axes
Shock resistance (Functional)	Min. 980 m/s ²			X, Y, Z axes
Ambient temperature	-20°C to +80°C -4°F to +176°F			Non-condensing at low temperatures
Storage temperature	-20°C to +85°C -4°F to +185°F			Non-condensing at low temperatures
Operational method	Zero-cross (Turn ON and Turn OFF)			

REFERENCE DATA

1. Load current vs. ambient temperature

Use load current within range specified in the figure below.

Tested condition

With external heat sink

- (1) When using standard heat sink (AQP-HS-J25A)
 - (2) When using standard heat sink (AQP-HS-30/40A)
 - (3) When using standard heat sink (AQP-HS-J10A)
 - (4) When using standard heat sink (AQP-HS-SJ20A)
- 2) If attached to a heat sink, use a heat conductive compound (Ex. Momentive Performance Materials Inc. YG6111 or TSK5303) of similar coating to improve cooling.

Without external heat sink

If the mounting surface is not metallic and a heat sink is not used, expose the bottom surface and plate surface to improve heat dissipation.

(1) 15A type (AQA211VL)

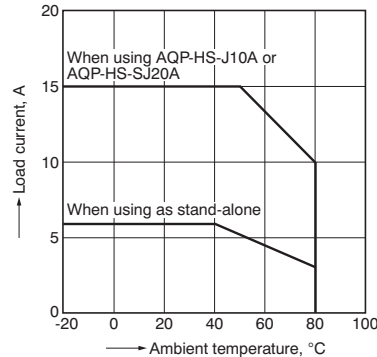

(2) 25A type (AQA411VL)

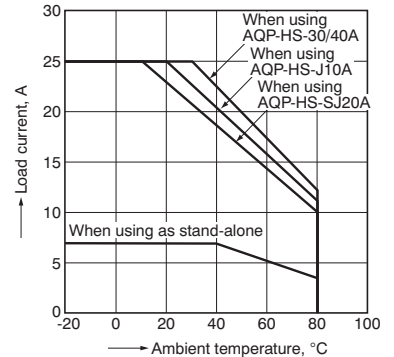

(3) 40A type (AQA611VL)

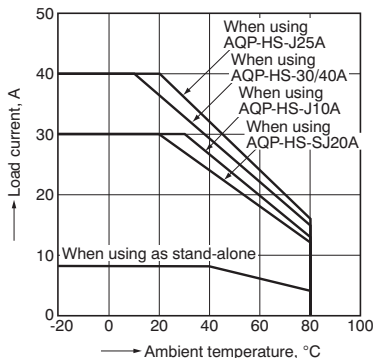

2. Non-repetitive surge current vs. carrying time characteristics

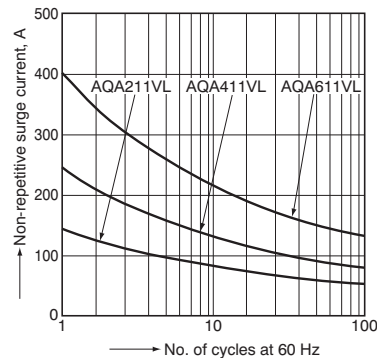

3. Input current vs. input voltage characteristics

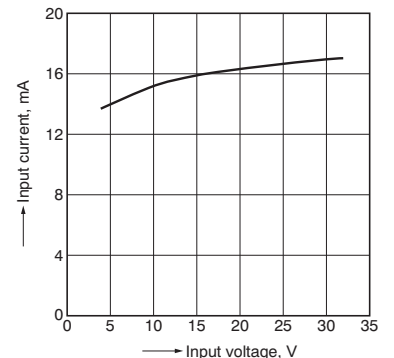

AQ-A

DIMENSIONS (mm inch)

Download **CAD Data** from our Web site.

CAD Data



External dimensions

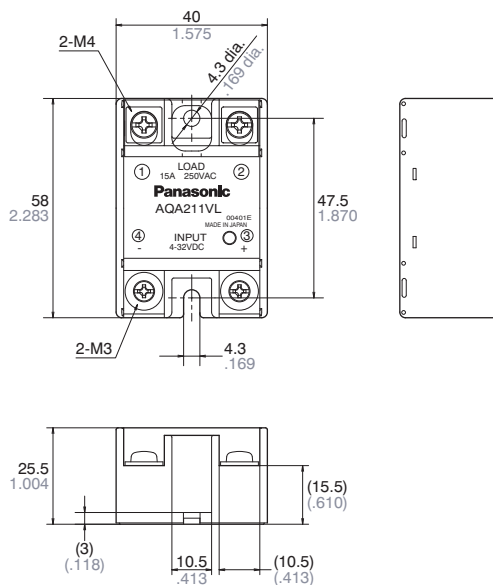

Schematic

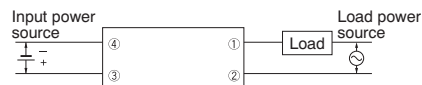

Mounting dimensions

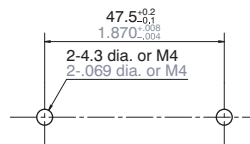

ACCESSORIES (mm inch)

AQP-HS-SJ20A Slim Heat Sink

CAD Data



External dimensions

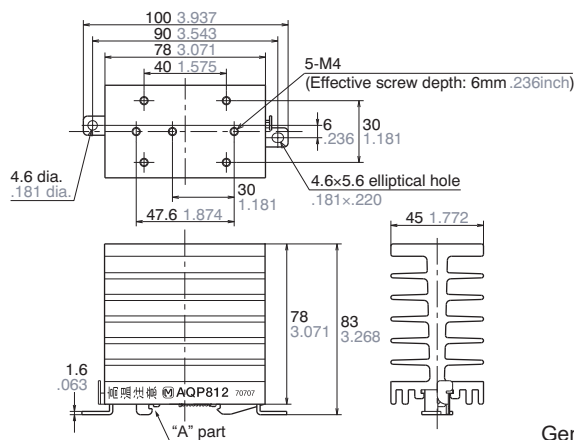

Mounting dimensions

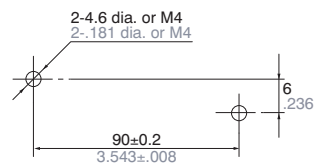

Note: When using on a DIN rail, please install so that the "A" part is on top.

General tolerance: $\pm 1.0 \pm .039$

AQP-HS-J10A Standard Heat Sink

CAD Data

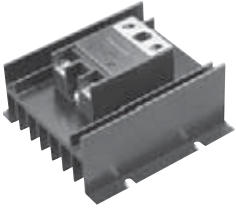

External dimensions

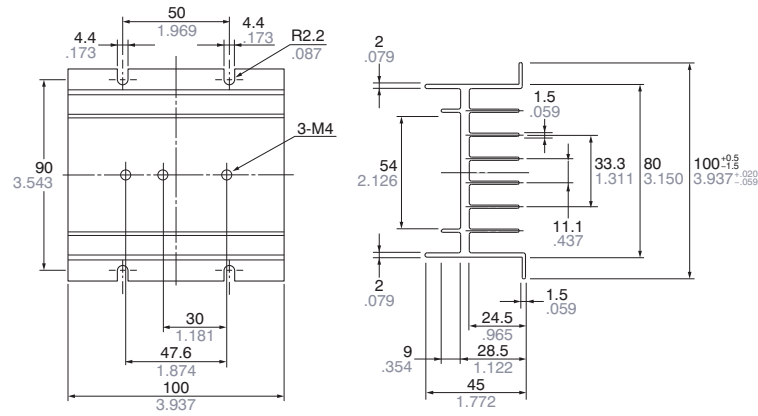

Mounting dimensions

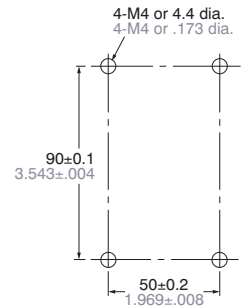

AQP-HS-30/40A Standard Heat Sink

CAD Data

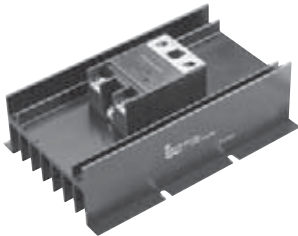

External dimensions

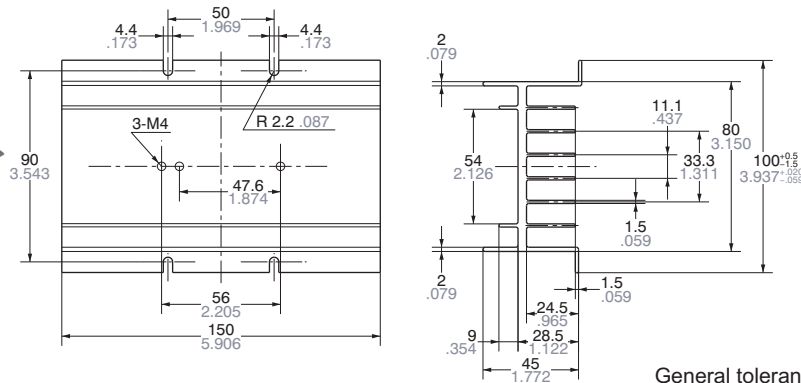

Mounting dimensions

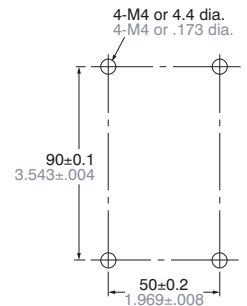
General tolerance: $\pm 0.5 \pm 0.020$

AQP-HS-J25A Standard Heat Sink

CAD Data

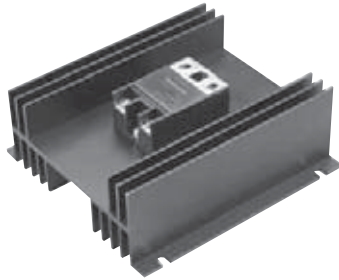

External dimensions

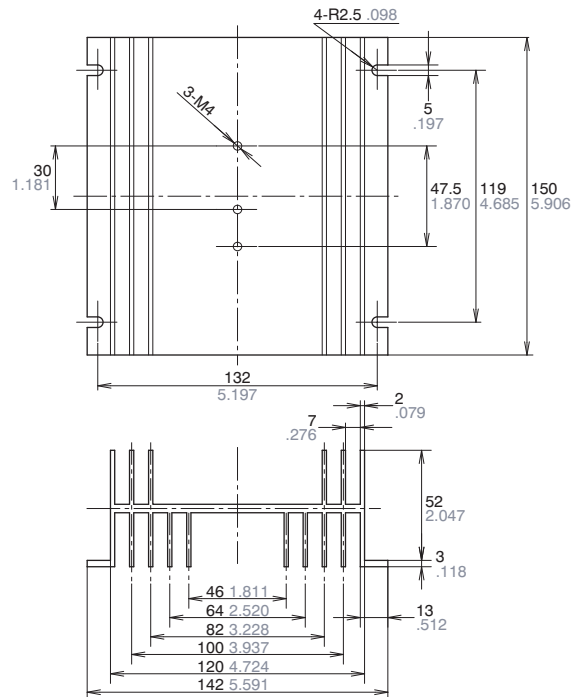

Mounting dimensions

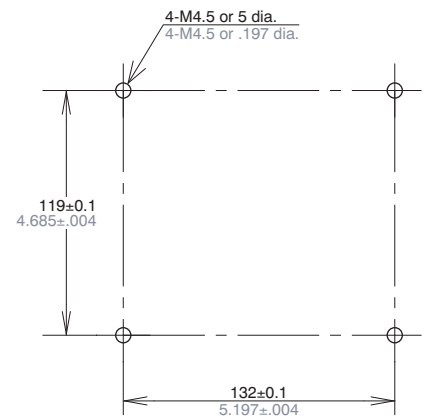

AQ-A

AQP-DPJ DIN Rail Mounting Plate

CAD Data

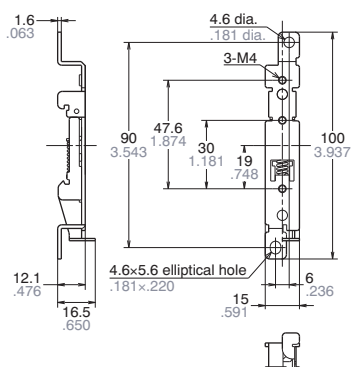

AT8-DLA1 Mounting Rail

CAD Data

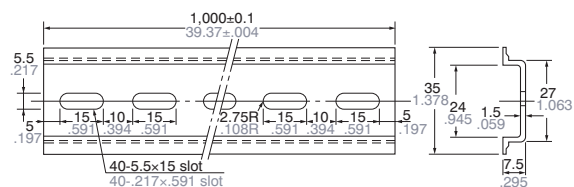

ATA4806 Fastening plate

CAD Data

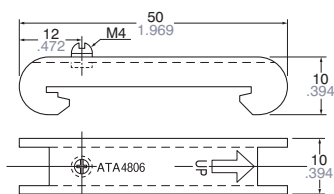

For Cautions for Use, see page 319.

Panasonic

ideas for life

 (Breakdown voltage 2,500V) (Breakdown voltage 4,000V)

10A and 25A DIN rail type

AQ-K RELAYS

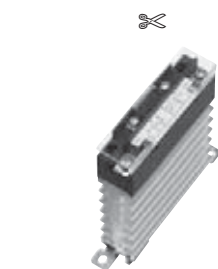

✂ Product to be discontinued.

FEATURES

- 1. Combined with heat sink for vertical profile**
Helps to save space on control panel
- 2. Dielectric voltage of 2,500V or 4,000V**
- 3. Both screw-on installation or one-touch DIN rail installation available**
- 4. Includes operation LED (red)**
- 5. Built-in varistor**

APPLICATIONS

1. Molding machine (heater control)
2. Temperature controlled bath (heater control)
3. Printing machine (heater control)
4. Machine tool (motor control)

TYPES

Type	Load current	Load voltage	Breakdown voltage	Part No.
Zero-cross	15 A	75 to 250 V AC	2,500 V AC	AQK1211
			4,000 V AC	AQK1231
	25 A	75 to 250 V AC	2,500 V AC	AQK2211
			4,000 V AC	AQK2231

ORDERING INFORMATION

Ex. AQK

Load current	Load voltage	Type	Input voltage
1: 15 A 2: 25 A	2: 75 to 250 V AC	1: Zero-cross type (2,500 V) 3: Zero-cross type (4,000 V)	1: 4.5 to 30 V DC

Note: Standard packing: Carton 10 pcs., Case: 60 pcs.

SPECIFICATIONS

1. **Ratings** (at 20°C 68°F, Input ripple: 1% or less)

1) 10 A type

Items	Type	AQK1211	AQK1231	AQK2211	AQK2231	Remarks
Input side	Input voltage	4.5 to 30 V DC				
	Input current, max.	10 mA				
	Drop-out voltage, min.	1 V				
Load side	Max. load current	15 A		25 A		See "REFERENCE DATA 1"
	Load voltage	75 to 250 V AC				
	Frequency	45 to 65 Hz				
	Non-repetitive surge current	150 A		250 A		In one cycle at 60 Hz
	Max. "OFF-state" leakage current	9 mA (when 200 V applied)				at 60 Hz
	Max. "ON-state" voltage drop	1.6 V				at max. carrying current
	Min. load current	100 mA				

2. **Characteristics** (at 20°C 68°F, Input ripple: 1% or less)

Part No.	AQK1211	AQK1231	AQK2211	AQK2231	Remarks
Operate time, max.	(1/2 cycle of voltage sine wave) + 1 ms				
Release time, max.	(1/2 cycle of voltage sine wave) + 1 ms				
Breakdown voltage	2,500 V AC	4,000 V AC	2,500 V AC	4,000 V AC	
Ambient temperature	-30°C to +80°C -22°F to +176°F				Non-condensing at low temperatures
Insulation resistance, min., Initial	100 M Ω between input, output and case				by 500V DC megger
Vibration resistance	10 to 55 Hz at double amplitude of 0.75 mm				For 1 min.
Shock resistance	Min. 294 m/s ²				
Storage temperature	-35°C to +100°C -31°F to +212°F				
Operational method	Zero-cross (Turn-ON and Turn-OFF)				

ds_61616_en_aqk: 011111D

369

Solid State

AQ-K

DIMENSIONS (mm inch)

Download **CAD Data** from our Web site.

CAD Data

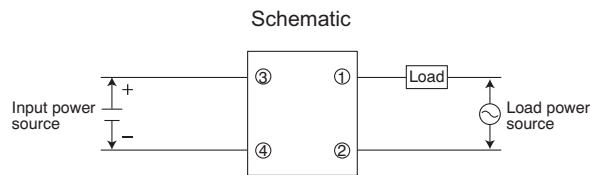
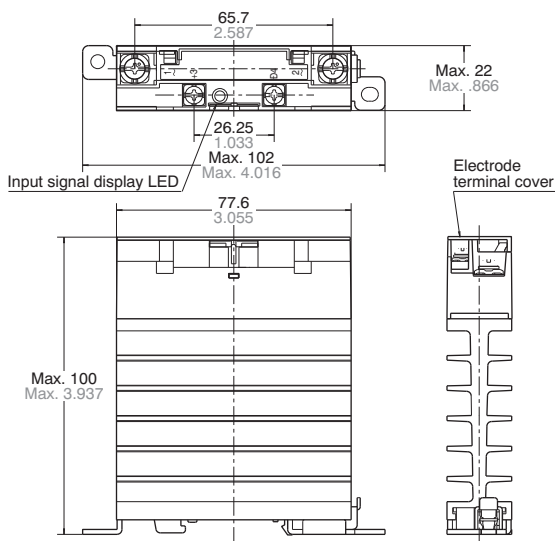
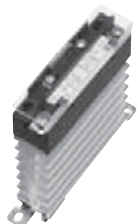

Mounting dimensions (Bottom view)
35-mm DIN rail installation, or 2-4.6/M4 dia. Screws

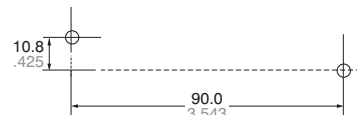

REFERENCE DATA

11. Load current vs. ambient temperature characteristics

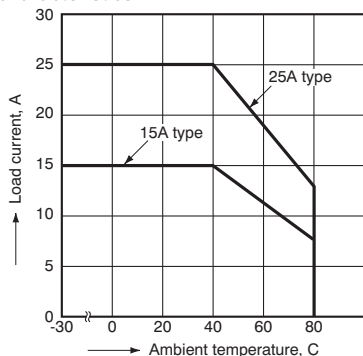

12. Non-repetitive surge current vs. carrying time (15 A, 25 A type)

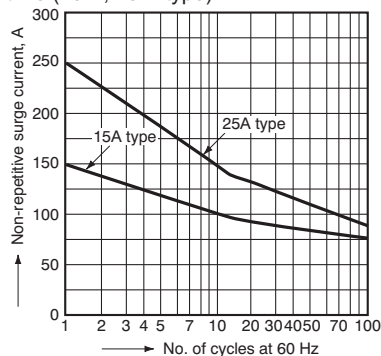

13. Input current vs. input voltage characteristics

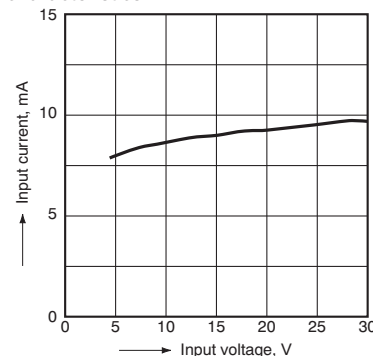

14-(1) Load current when contact mounted vs. ambient temperature characteristics

Tested sample: AQK1211, AQK1231

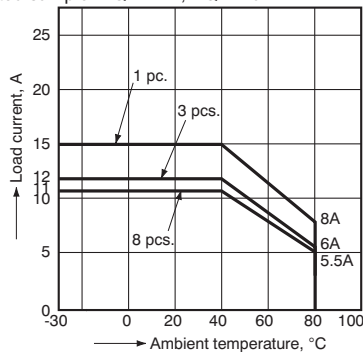

4-(2) Load current when contact mounted vs. ambient temperature characteristics

Tested sample: AQK2211, AQK2231

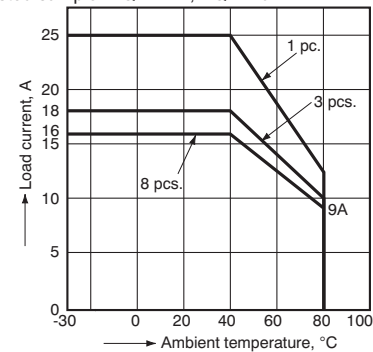

For Cautions for Use, see Page 319.



Please contact us about TUV certified products.

Panasonic

ideas for life

Input and output module
compact DIL type

AQ-C RELAYS

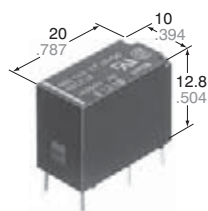

mm inch

FEATURES

- **Compact DIL type: 20 mm (length) × 10 mm (width) × 12.8 mm (height) (.787×.394×.504 inch)**
- **Excellent in noise resistance**
- **Snubber circuit integrated**
- **High dielectric strength: 2,500 V between input and output**
- **Reverse polarity type available**

TYPES

1. Input module

Type	Output voltage	Input voltage	Part No.
AC input	4 to 32 V DC	80 to 250 V AC	AQCD3-IM 100/240 V AC
DC input	4 to 32 V DC	3 to 32 V DC	AQCD3-IM 4/24 V DC

2. Output module

Type	Load voltage	Input voltage	Part No.
AC output Zero-cross	75 to 125 V AC	5 V DC	AQC1A1 - ZT5 V DC
		12 V DC	AQC1A1 - ZT12 V DC
		24 V DC	AQC1A1 - ZT24 V DC
	75 to 250 V AC	5 V DC	AQC1A2 - ZT5 V DC
		12 V DC	AQC1A2 - ZT12 V DC
		24 V DC	AQC1A2 - ZT24 V DC
AC output Non zero-cross	75 to 125 V AC	5 V DC	AQC1A1 - T 5 V DC
		12 V DC	AQC1A1 - T 12 V DC
		24 V DC	AQC1A1 - T 24 V DC
	75 to 250 V AC	5 V DC	AQC1A2 - T 5 V DC
		12 V DC	AQC1A2 - T 12 V DC
		24 V DC	AQC1A2 - T 24 V DC
DC output	3 to 60 V DC	5 V DC	AQC1AD1- 5 V DC
		12 V DC	AQC1AD1- 12 V DC
		24 V DC	AQC1AD1- 24 V DC

ORDERING INFORMATION

Load current	Load voltage	Type	Input voltage	Input polarity
Nil: Input module 1A: Output module	1: 75 to 125 V AC (Output module) 2: 75 to 250 V AC (Output module) D1: 3 to 60 V DC (Output module) D3: 4 to 32 V DC (Input module)	Nil: DC output IM: Input module T: AC output Non zero-cross ZT: AC output Zero-cross	Output module: 5, 12, 24 V DC Input module: 4/24 V DC, 100/240 V AC	Nil: Standard polarity R: Reverse polarity (Only for output module)

Standard packing: Carton: 50 pcs.; Case: 500 pcs.

AQ-C

SPECIFICATIONS

Rating [at 20°C 68°F; Input voltage ripple (output module) and output voltage ripple (input module): max. 1%]

1. Input module

Item	Type	AC input	DC input	Remarks
		AQCD3-IM 100/240 V AC	AQCD3-IM 4/24 V DC	
Input side	Input voltage	80 to 250 V AC	3 to 32 V DC	
	Input current	Max. 5 mA	Max. 5 mA	
	Pick-up voltage	Max. 80 V AC	Max. 3 V DC	
	Drop-out voltage	Min. 10 V AC	Min. 1 V DC	
Output side	Load voltage	4 to 32 V DC	4 to 32 V DC	
	Load current	0.1 to 25 mA	0.1 to 25 mA	
	Max. "OFF-state" leakage current	Max. 5μA	Max. 5μA	When 32 V DC applied
	Max. "ON-state" voltage drop	Max. 1.6 V	Max. 1.6 V	at max. carrying current

2. Output module

(1) AC output type

Item	Type	AQC1A1-ZT5VDC	AQC1A1-ZT12VDC	AQC1A1-ZT24VDC	AQC1A2-ZT5VDC	AQC1A2-ZT12VDC	AQC1A2-ZT24VDC	Remarks
		AQC1A1-T5VDC	AQC1A1-T12VDC	AQC1A1-T24VDC	AQC1A2-T5VDC	AQC1A2-T12VDC	AQC1A2-T24VDC	
Input side	Input voltage	(5 V type) 4 to 6 V DC	(12 V type) 9.6 to 14.4 V DC	(24 V type) 21.6 to 26.4 V DC	(5 V type) 4 to 6 V DC	(12 V type) 9.6 to 14.4 V DC	(24 V type) 21.6 to 26.4 V DC	See "Data 3".
	Input impedance (Approx.)	0.3 kΩ	0.8 kΩ	1.8 kΩ	0.3 kΩ	0.8 kΩ	1.8 kΩ	
	Drop-out voltage, min	0.5 V	1.2 V	2.4 V	0.5 V	1.2 V	2.4 V	
Load side	Max. load current	1 A						See "Data 1". Ta = Min. 40°C
	Load voltage	75 to 125 V AC			75 to 250 V AC			
	Non-repetitive surge current	20 A						
	Max. "OFF-state" leakage current	0.6 mA (When 100 V AC applied)			1.1 mA (When 200 V AC applied)			
	Max. "ON-state" voltage drop	1.6 A						
	Min. load current	10 mA			20 mA			

(2) DC output type

Item	Type	AQC1AD1-5VDC	AQC1AD1-12VDC	AQC1AD1-24VDC	Remarks
		(5 V type) 4 to 6 V DC	(12 V type) 9.6 to 14.4 V DC	(24 V type) 21.6 to 26.4 V DC	
Input side	Input voltage	(5 V type) 4 to 6 V DC	(12 V type) 9.6 to 14.4 V DC	(24 V type) 21.6 to 26.4 V DC	See "Data 3".
	Input impedance (Approx.)	430 Ω	1.2 kΩ	2.8 kΩ	
	Drop-out voltage, min	0.8 V			
Load side	Max. load current	1 A			See "Data 1". Ta = Min. 40°C
	Load voltage	3 to 60 V DC			
	Non-repetitive surge current	1.5 A			
	Max. "OFF-state" leakage current	0.1 mA (When 60 V DC applied)			
	Max. "ON-state" voltage drop	1.6 V			
	Min. load current	1 mA			

Characteristics [at 20°C 68°F; Input voltage ripple (output module) and output voltage ripple (input module): max. 1%]

Input module

Item	Type	AC Input	DC Input	Remarks
		Operate time, max.	20 ms	
Release time, max	20 ms	0.5 ms		
Insulation resistance, min.	10 ⁹ Ω between input and output			at 500 V DC
Breakdown voltage	2,500 Vrms between input and output			For 1 minute
Vibration resistance	Functional	10 to 55Hz double amplitude of 3 mm		10 minutes for X,Y, Z, axis
	Destructive	10 to 55Hz double amplitude of 3 mm		1 hour for X,Y, Z, axis
Shock resistance	Functional	Min. 980 m/s ² {100 G}		4 time each for X,Y,Z axis
	Destructive	Min. 980 m/s ² {100 G}		5 time each for X,Y,Z axis
Ambient temperature	-30°C to +80°C -22°F to +176°F			
Storage temperature	-30°C to +100°C -22°F to +212°F			

Output module

Item	Type	AC output		DC output	Conditions
		Non zero-cross	Zero-cross		
Operate time, max.		1 ms	(1/2 cycle of voltage sine wave)+1ms	0.5 ms	
Release time, max.		(1/2 cycle of voltage sine wave)+1ms		1 ms	
Insulation resistance, min.		10 ⁹ Ω between input and output			at 500 V DC
Breakdown voltage		2,500 Vrms between input and output			For 1 minute
Vibration resistance	Functional	10 to 55Hz double amplitude of 3 mm			10 minutes for X,Y, Z, axis
	Destructive	10 to 55Hz double amplitude of 3 mm			1 hour for X,Y, Z, axis
Shock resistance	Functional	Min. 980 m/s ² {100 G}			4 time each for X,Y,Z axis
	Destructive	Min. 980 m/s ² {100 G}			5 time each for X,Y,Z axis
Ambient temperature		-30°C to +80°C -22°F to +176°F			
Storage temperature		-30°C to +100°C -22°F to +212°F			
Operational method		Non zero-cross Turn-ON, Zero-cross Turn-OFF	Zero-cross (Turn-ON and Turn-OFF)	—	

DIMENSIONS (mm inch)

Download [CAD Data](#) from our Web site.

1. Input module (AC, DC)

CAD Data

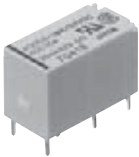

AC input
 ⑤ Output: DC-
 ⑧ Output: DC+
 ⑩ Input: AC
 ⑪ Input: AC
 Case color: Yellow

DC input
 ⑤ Output: DC-
 ⑧ Output: DC+
 ⑩ Input: DC+
 ⑪ Input: DC-
 Case color: White

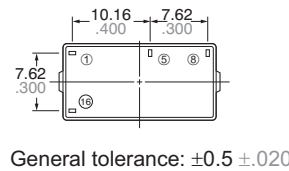
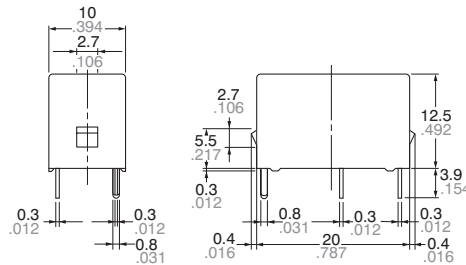

PC board pattern (Copper-side view)

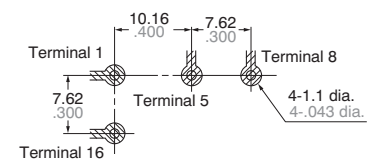
Tolerance: $\pm 0.1 \pm 0.004$

Schematic

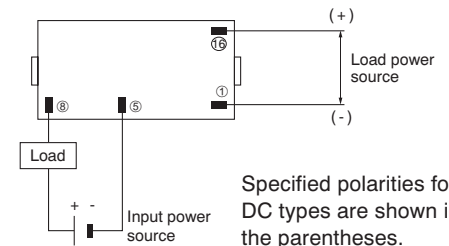

Specified polarities for DC types are shown in the parentheses.

2. Output module (AC, DC)

CAD Data



AC output
 ⑤ Output: AC
 ⑧ Output: AC
 ⑩ Input: DC+
 ⑪ Input: DC-
 Case color: Black

DC output
 ⑤ Output: DC-
 ⑧ Output: DC+
 ⑩ Input: DC+
 ⑪ Input: DC-
 Case color: Red

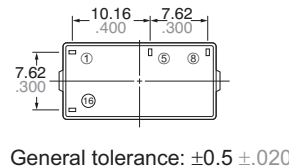
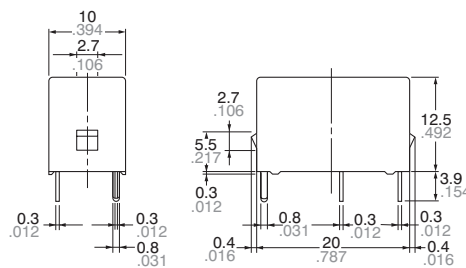

PC board pattern (Copper-side view)

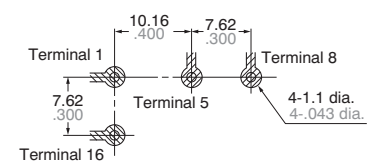
Tolerance: $\pm 0.1 \pm 0.004$

Schematic

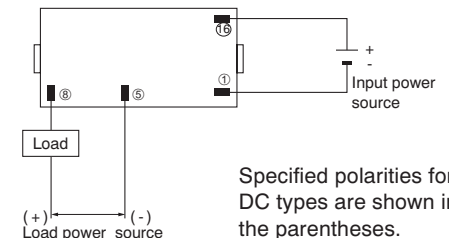

Specified polarities for DC types are shown in the parentheses.

AQ-C

ACCESSORY



PC1A-PS

REFERENCE DATA

15. Load current vs. ambient temperature

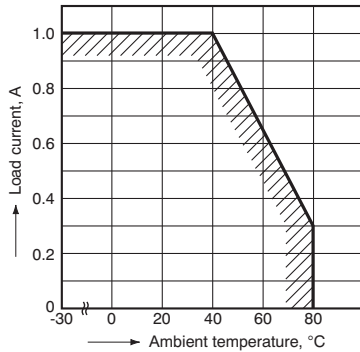

16-(1) Non-repetitive surge current vs. carrying time (AC output)

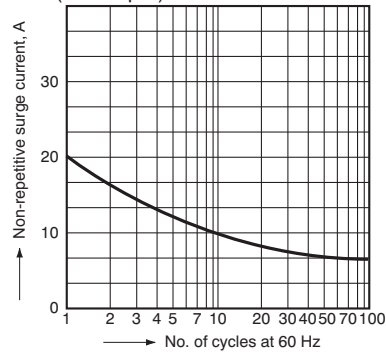

2.-(2) Non-repetitive surge current vs. carrying time (DC output)

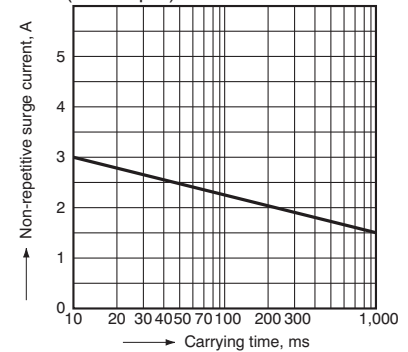

17. Input current vs. input voltage characteristics (AC/DC output)

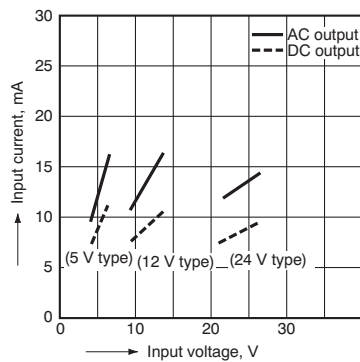

18-(1) Input current vs. input voltage characteristics (AC input)

Tested sample: AQCD3-IM100/240 V AC, 5 pcs.

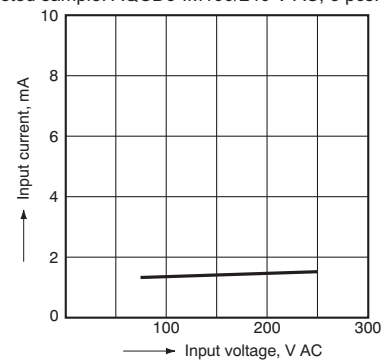

4.-(2) Input current vs. input voltage characteristics (DC input)

Tested sample: AQCD3-IM4/24 V DC

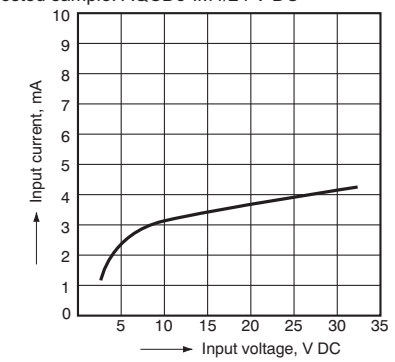

19. Load current vs. ambient temperature characteristics for adjacent mounting

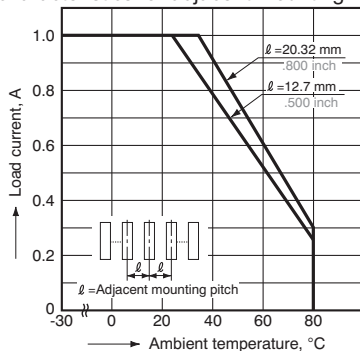



Panasonic
ideas for life

Input/Output relays
for interface applications

I/O-RELAYS

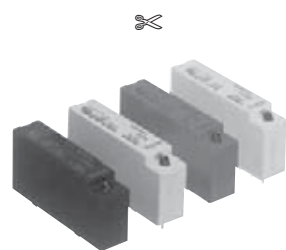

⌘ Product to be discontinued.

FEATURES

- **Input and output modules for interfacing between CPU and external input devices or loads**
IAC: AC input (yellow)
OAC: AC output (black)
IDC: DC input (white)
ODC: DC output (red)
- **Excellent transient noise immunity**
- **Breakdown voltage: 4,000 V between input and output**
- **Zero-cross switching for reducing EMI**
- **LED operation indication types available**

TYPICAL APPLICATIONS

1. Optimum for minicomputer and microcomputer use, and for feed back control process control systems. Robot, NC machine, Automatic Assembling machine.
2. Programmable controllers controls for motors, solenoids and solenoid valves.

ORDERING INFORMATION

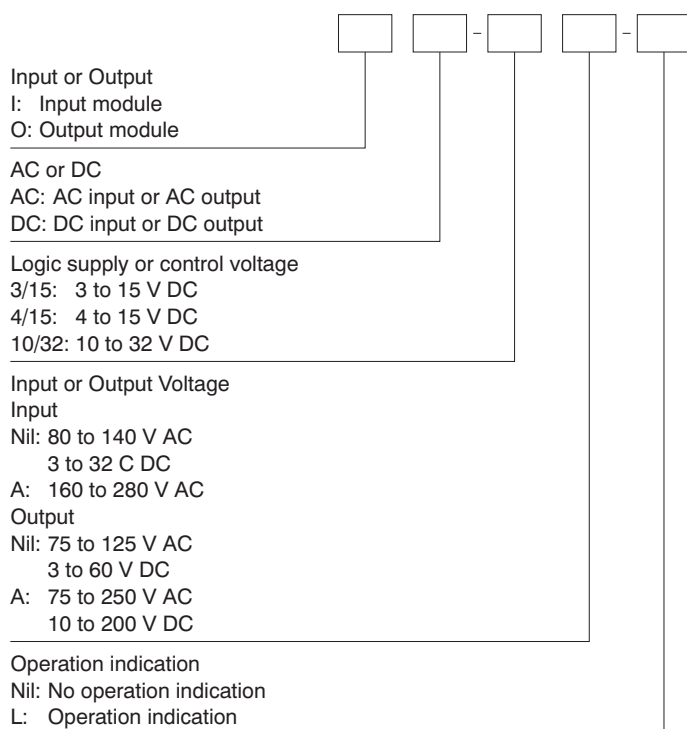

EXAMPLE OF I/O SYSTEM CONSTRUCTION

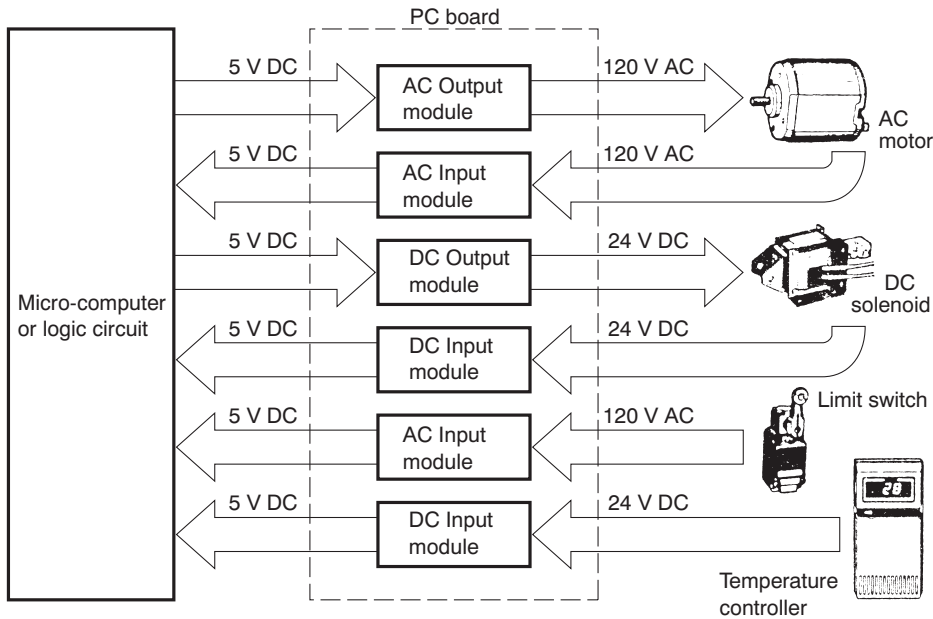

Recently, the microcomputer shown in the left has come into use, with a rapid increase in the use of feedback control for process controllers. As an input/output interface relay, it represents a fast responding interface with long life, noiseless, PC board mounting facility, making circuit design and manufacture simple, and providing amplification of maintenance with space saving. Our company's I/O relays have been grouped for use with either AC or DC devices as AC output type, AC input type, DC output type, and DC input. In addition, the I/O use relay is modularized identically, responding to the various load types for PC board mounting. Because combinations can be freely used, circuit design has been greatly facilitated. Accordingly, the above diagram of interface PC board mounting is a practical construction which can be used.

TYPES

Input modules

Type	Logic supply voltage	Input voltage	Part No.	
			No LED	With LED
AC	4 to 15 V DC	80 to 140 V AC	IAC4/15	IAC4/15-L
		160 to 280 V AC	IAC4/15-A	IAC4/15-AL
	10 to 32 V DC	80 to 140 V AC	IAC10/32	IAC10/32-L
		160 to 280 V AC	IAC 10/32-A	IAC10/32-AL
DC	4 to 15 V DC	3 to 32 V DC	IDC4/15	IDC4/15-L
	10 to 32 V DC	3 to 32 V DC	IDC10/32	IDC10/32-L

Standard packing: Carton: 20 pcs.; Case: 200 pcs.

Output modules

Type	Logic supply voltage	Output voltage	Part No.	
			No LED	With LED
AC	3 to 15 V DC or 4 to 15 V DC	75 to 125 V AC	OAC3/15	OAC4/15-L
		75 to 250 V AC	OAC3/15-A	OAC4/15-AL
	10 to 32 V DC	75 to 125 V AC	OAC10/32	OAC10/32-L
		75 to 250 V AC	OAC10/32-A	OAC10/32-AL
DC	3 to 15 V DC or 4 to 15 V DC	3 to 60 V DC	ODC3/15	ODC4/15-L
		10 to 200 V DC	ODC3/15-A	ODC4/15-AL
	10 to 32 V DC	3 to 60 V DC	ODC10/32	ODC10/32-L
		10 to 200 V DC	ODC10/32-A	ODC10/32-AL

Standard packing: Carton: 20 pcs.; Case: 200 pcs.

I/O

SPECIFICATIONS**Rating** (at 20°C 68°F, Voltage ripple of logic side: less than 1%)**1. Input module**

		IAC 4/15	IAC 4/15-L	IAC 10/32	IAC 10/32-L	IAC 4/15-A	IAC 4/15-AL	IAC 10/32-A	IAC 10/32-AL	IDC 4/15	IDC 4/15-L	IDC 10/32	IDC 10/32-L	Remarks
Input side	Input voltage	80 to 140 V AC				160 to 280 V AC				3 to 32 V DC				
	Input current, Max.	5 mA (100 V)				5 mA (200 V)				20 mA (32 V)				
	Operate voltage, Max.	80 V AC				160 V AC				3 V				
	Release voltage Min.	10 V AC				20 V AC				0.8 V				
Logic side	Logic supply voltage	4 to 15 V		10 to 32 V		4 to 15 V		10 to 32 V		4 to 15 V		10 to 32 V		
	Logic supply current, Max.	15 mA								15 mA				at max. logic supply voltage
	Breakdown voltage	30 V								30 V				
	Output current, Max.	25 mA								25 mA				
	Max. "OFF-side" leakage current	100 µA								100 µA				
	Max. "ON-side" voltage drop	0.4 V								0.4 V				at max. carrying current

2. Output module

		OAC 3/15	OAC 4/15-L	OAC 10/32	OAC 10/32-L	OAC 3/15-A	OAC 4/15-AL	OAC 10/32-A	OAC 10/32-AL	ODC 3/15	ODC 4/15-L	ODC 10/32	ODC 10/32-L	ODC 3/15-A	ODC 4/15-AL	ODC 10/32-A	ODC 10/32-AL	Remarks
Logic side	Logic voltage range	3 to 15 V	4 to 15 V	10 to 32 V		3 to 15 V	4 to 15 V	10 to 32 V		3 to 15 V	4 to 15 V	10 to 32 V		3 to 15 V	4 to 15 V	10 to 32 V		
	Input Impedance (Approx.)	1.6 kΩ	1.7 kΩ	6 kΩ	5 kΩ	1.6 kΩ	1.7 kΩ	6 kΩ	5 kΩ	1.6 kΩ	1.7 kΩ	6 kΩ	5 kΩ	1.6 kΩ	1.7 kΩ	6 kΩ	5 kΩ	*1
	Drop-out voltage, Min.	0.8V								0.8V								
Output side	Max. load current	2 A (Ambient temperature: Max. 30°C)*2								2 A (Ambient temperature: Max. 40°C)*2				1 A (Ambient temperature: Max. 40°C)*2				
	Output voltage	75 to 125 V AC				75 to 250 V AC				3 to 60 V DC				10 to 200 V DC				
	Non-repetitive surge current	30 A (in one cycle at 60 Hz)*3								5 A (for 1 s)*3								
	Max. "OFF-state" leakage current	5 mA (100 V)				5 mA (200 V)				1 mA (60 V)				1 mA (200 V)				at 60 Hz
	Max. "ON-state" voltage current	1.6 V								1.6 V				2.3 V				at max. carrying current
	Min. load current	50 mA*4								5 mA*4								

Notes: *1. Please refer to REFERENCE DATA, "3. Input current vs. input voltage".

*2. Please refer to REFERENCE DATA, "1. Load current vs. ambient temperature".

*3. Please refer to REFERENCE DATA, "2. Surge current vs. time".

*4. When the load current is less than the rated minimum load current, please refer to the Cautions for Use, on Page 319.

Characteristics (at 20°C 68°F, Voltage ripple of logic side: less than 1%)

		Input modules				Output modules				
		IAC		IDC		OAC		ODC		
Operate time, max.		20 ms		5 ms		1/2 cycle of voltage sine wave + 1 ms		0.5 ms		
Release time, max.		20 ms		5 ms		1/2 cycle of voltage sine wave + 1 ms		2 ms		
Insulation resistance		10 ⁹ Ω between input and output (at 500 V DC)								
Breakdown voltage		4,000 V AC between input and output (for 1 min.)								
Vibration resistance	Destructive	10 to 55 Hz at double amplitude of 2 mm (1hour for X, Y, Z axis)								
	Functional	10 to 55 Hz at double amplitude of 2 mm (10 minutes for X, Y, Z axis)								
Shock resistance	Destructive	Min. 980 m/s ² {100G} (5 times each for X, Y, Z axis)								
	Functional	Min. 980 m/s ² {100G} (4 times each for X, Y, Z axis)								
Ambient temperature		-30°C to +80°C -22°F to +176°F				-30°C to +80°C -22°F to +176°F				
Storage temperature		-30°C to +100°C -22°F to +212°F				-30°C to +100°C -22°F to +212°F				
Operational method		-				Zero-cross (Turn-ON and Turn-OFF)				-

REFERENCE DATA

1-1. Load current vs. ambient temperature (OAC)

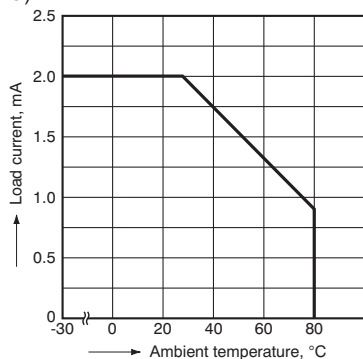

1-2. Load current vs. ambient temperature (ODC)

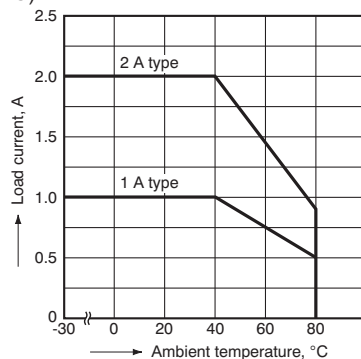

2-1. Surge current vs. time (OAC)

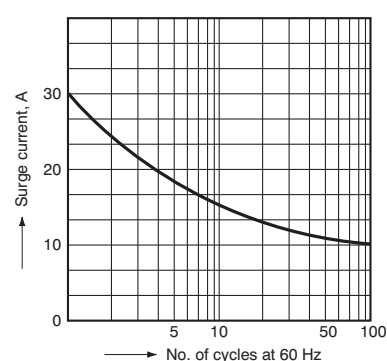

2-2. Surge current vs. time (ODC)

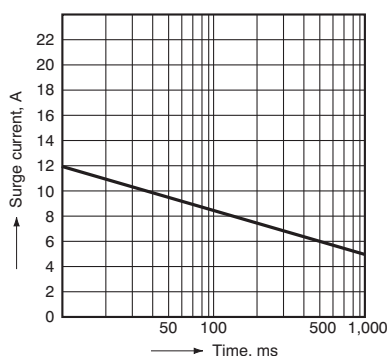

3. Input current vs. input voltage (OAC, ODC)

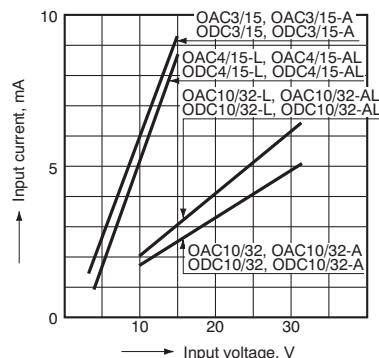

DIMENSIONS (mm inch)

✂ Input module (IAC, IDC)

CAD Data

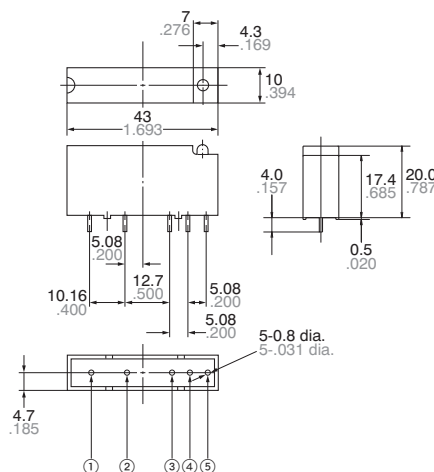

Download **CAD Data** from our Web site.

PC board pattern (Bottom view)

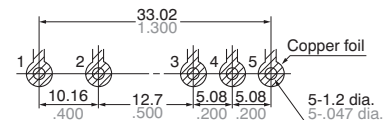

	IAC	IDC
1	Input: AC	Input: DC +
2	Input: AC	Input: DC -
3	Vcc	Vcc
4	Logic output	Logic output
5	Grounding	Grounding
Body color	Yellow	White

I/O

Output modules (OAC, ODC)

CAD Data

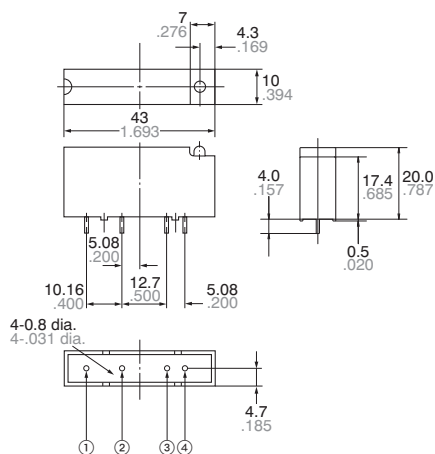
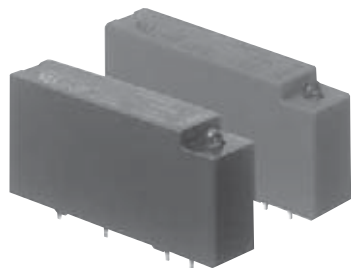

PC board pattern (Bottom view)

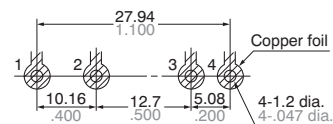

	OAC	ODC
1	Output: AC	Output: DC +
2	Output: AC	Output: DC -
3	Input: DC+	Input: DC+
4	Input: DC-	Input: DC-
Body color	Black	Red

BLOCK DIAGRAM

1) AC input module

Without LED

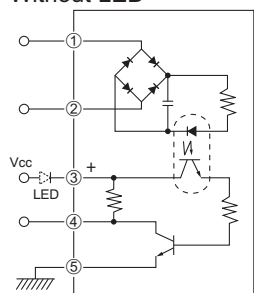

With LED

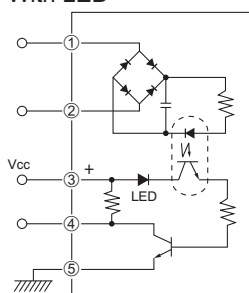

2) DC input module

Without LED

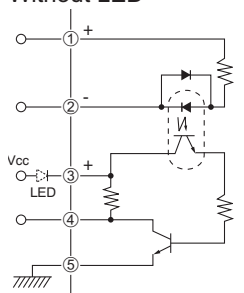

With LED

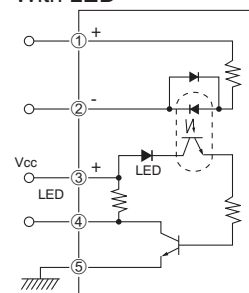

3) AC output module

Without LED

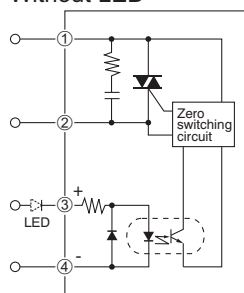

With LED

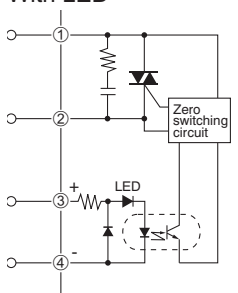

4) DC output module

Without LED

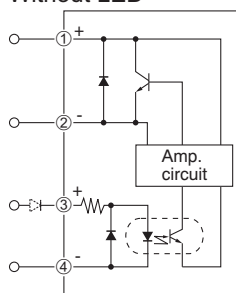

With LED

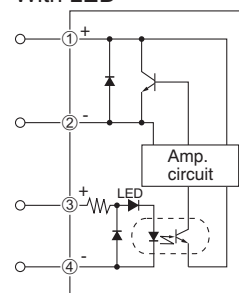

ACCESSORIES

I/O Socket

CAD Data



I/O-PS

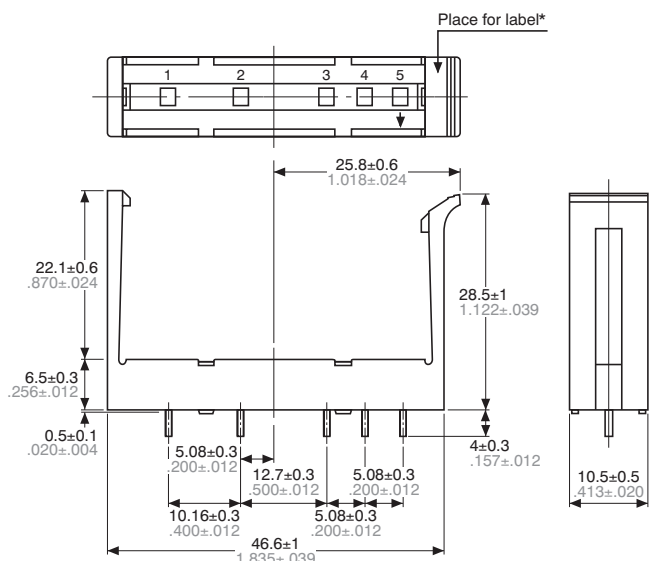

PC board pattern (Bottom view)

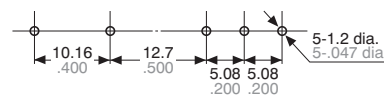

* Use the included label. Affixing it here on the socket will facilitate viewing of the circuit and other tasks.

For Cautions for Use, see Page 319.