

Six-Pack Trench IGBT

$$V_{CES} = 1200 \text{ V}$$

$$I_{C25} = 215 \text{ A}$$

$$V_{CE(sat)} = 1.7 \text{ V}$$

Part name (Marking on product)

MWI150-12T8T

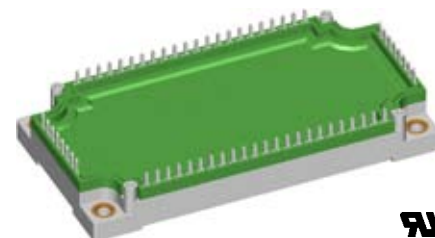
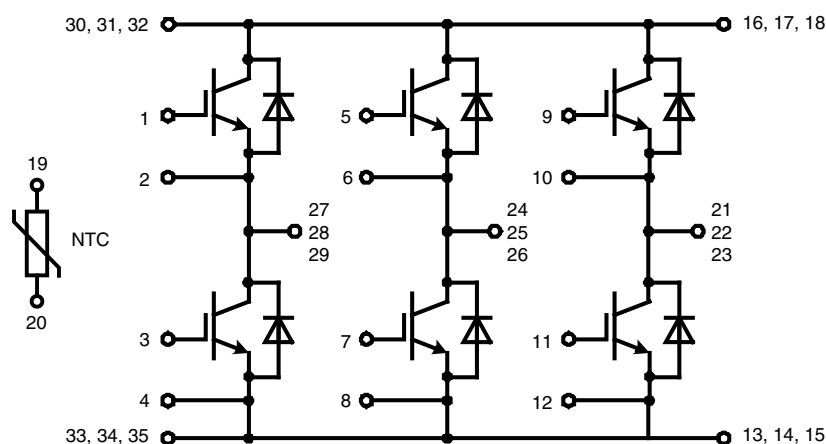

E 72873

Pin configuration see outlines.

Features:

- Trench IGBT technology
- low saturation voltage
- low switching losses
- square RBSOA, no latch up
- high short circuit capability
- positive temperature coefficient for easy paralleling
- MOS input, voltage controlled
- ultra fast free wheeling diodes
- solderable pins for PCB mounting
- package with copper base plate

Application:

- AC motor drives
- Solar inverter
- Medical equipment
- Uninterruptible power supply
- Air-conditioning systems
- Welding equipment
- Switched-mode and resonant-mode power supplies

Package:

- "E3-Pack" standard outline
- Insulated copper base plate
- Soldering pins for PCB mounting
- Temperature sense included



MWI150-12T8T

Output Inverter T1 - T6

Symbol	Definitions	Conditions	Ratings				
			min.	typ.	max.	Unit	
V_{CES}	collector emitter voltage		$T_{VJ} = 25^{\circ}\text{C}$		1200	V	
V_{GES}	max. DC gate voltage	continuous			± 20	V	
V_{GEM}	max. transient collector gate voltage	transient			± 30	V	
I_{C25}	collector current		$T_C = 25^{\circ}\text{C}$		215	A	
I_{C80}			$T_C = 80^{\circ}\text{C}$		150	A	
P_{tot}	total power dissipation		$T_C = 25^{\circ}\text{C}$		690	W	
$V_{CE(sat)}$	collector emitter saturation voltage	$I_C = 150\text{ A}; V_{GE} = 15\text{ V}$	$T_{VJ} = 25^{\circ}\text{C}$ $T_{VJ} = 125^{\circ}\text{C}$	1.7 2.0	2.1	V V	
$V_{GE(th)}$	gate emitter threshold voltage	$I_C = 6\text{ mA}; V_{GE} = V_{CE}$	$T_{VJ} = 25^{\circ}\text{C}$	5.0	5.8	6.5	V
I_{CES}	collector emitter leakage current	$V_{CE} = V_{CES}; V_{GE} = 0\text{ V}$	$T_{VJ} = 25^{\circ}\text{C}$ $T_{VJ} = 125^{\circ}\text{C}$		6	2	mA mA
I_{GES}	gate emitter leakage current	$V_{GE} = \pm 20\text{ V}$			500	nA	
C_{ies}	input capacitance	$V_{CE} = 25\text{ V}; V_{GE} = 0\text{ V}; f = 1\text{ MHz}$			10770	pF	
$Q_{G(on)}$	total gate charge	$V_{CE} = 600\text{ V}; V_{GE} = 15\text{ V}; I_C = 150\text{ A}$			860	nC	
$t_{d(on)}$	turn-on delay time	} inductive load $V_{CE} = 600\text{ V}; I_C = 150\text{ A}$ $V_{GE} = \pm 15\text{ V}; R_G = 2.4\ \Omega$ $L_S = 70\text{ nH}$	$T_{VJ} = 125^{\circ}\text{C}$		270	ns	
t_r	current rise time				50	ns	
$t_{d(off)}$	turn-off delay time				500	ns	
t_f	current fall time				340	ns	
E_{on}	turn-on energy per pulse				15.5	mJ	
E_{off}	turn-off energy per pulse				20	mJ	
RBSOA	reverse bias safe operating area	$V_{GE} = \pm 15\text{ V}; R_G = 2.4\ \Omega;$	$T_{VJ} = 125^{\circ}\text{C}$ $V_{CEK} = 1200\text{ V}$		300	A	
SCSOA	short circuit safe operating area		$T_{VJ} = 125^{\circ}\text{C}$		10	μs	
t_{SC}	short circuit duration	$V_{CE} = 900\text{ V}; V_{GE} = \pm 15\text{ V};$			600	A	
I_{SC}	short circuit current	$R_G = 2.4\ \Omega; \text{non-repetitive}$					
R_{thJC}	thermal resistance junction to case	(per IGBT)			0.18	K/W	

Output Inverter D1 - D6

Symbol	Definitions	Conditions	Ratings			
			min.	typ.	max.	Unit
V_{RRM}	max. repetitive reverse voltage		$T_{VJ} = 25^{\circ}\text{C}$		1200	V
I_{F25}	forward current		$T_C = 25^{\circ}\text{C}$		196	A
I_{F80}			$T_C = 80^{\circ}\text{C}$		132	A
V_F	forward voltage	$I_F = 150\text{ A}; V_{GE} = 0\text{ V}$	$T_{VJ} = 25^{\circ}\text{C}$ $T_{VJ} = 125^{\circ}\text{C}$	1.95 1.85	2.2	V V
Q_{rr}	reverse recovery charge	} $V_R = 600\text{ V}$ $di_f/dt = -2900\text{ A}/\mu\text{s}$ $I_F = 150\text{ A}; V_{GE} = 0\text{ V}$	$T_{VJ} = 125^{\circ}\text{C}$		20	μC
I_{RM}	max. reverse recovery current				160	A
t_{rr}	reverse recovery time				320	ns
E_{rec}	reverse recovery energy				7	mJ
R_{thJC}	thermal resistance junction to case	(per diode)			0.28	K/W

 $T_C = 25^{\circ}\text{C}$ unless otherwise stated

Temperature Sensor NTC

Symbol	Definitions	Conditions	Ratings			
			min.	typ.	max.	Unit
R_{25}	resistance	$T_C = 25^\circ\text{C}$	4.75	5.0	5.25	k Ω
$B_{25/50}$				3375		K

Module

Symbol	Definitions	Conditions	Ratings			
			min.	typ.	max.	Unit
T_{VJ}	operating temperature		-40		125	$^\circ\text{C}$
T_{VJM}	max. virtual junction temperature				150	$^\circ\text{C}$
T_{stg}	storage temperature		-40		125	$^\circ\text{C}$
V_{ISOL}	isolation voltage	$I_{ISOL} \leq 1 \text{ mA}; 50/60 \text{ Hz}$			2500	V~
CTI	comparative tracking index				-	
M_d	mounting torque (M5)		2.7		3.3	Nm
d_S	creep distance on surface		10			mm
d_A	strike distance through air		7.5			mm
$R_{pin-chip}$	resistance pin to chip			2.5		m Ω
R_{thCH}	thermal resistance case to heatsink	with heatsink compound		0.02		K/W
Weight				300		g

0.0 Equivalent Circuits for Simulation

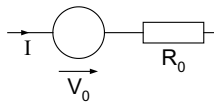

Ratings

Symbol	Definitions	Conditions	min.	typ.	max.	Unit
V_0 R_0	IGBT	T1 - T6 $T_{VJ} = 125^\circ\text{C}$		1.0 6.7		V m Ω
V_0 R_0	Diode	D1 - D6 $T_{VJ} = 125^\circ\text{C}$		1.15 4.7		V m Ω

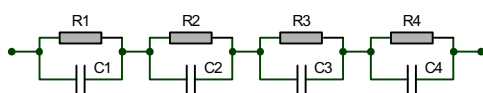

$$Z_{th}(t) = \sum_{i=1}^n \left[R_i \cdot \left(1 - \exp\left(-\frac{t}{\tau_i}\right) \right) \right]$$

$$\tau_i = R_i \cdot C_i$$

	IGBT	Diode
R_1	0.0267	0.054
R_2	0.0309	0.05
R_3	0.061	0.096
R_4	0.0614	0.08
τ_1	0.0025	0.0025
τ_2	0.076	0.076
τ_3	0.036	0.036
τ_4	0.076	0.076

$T_C = 25^\circ\text{C}$ unless otherwise stated

IXYS MWI150-12T8T

Circuit Diagram

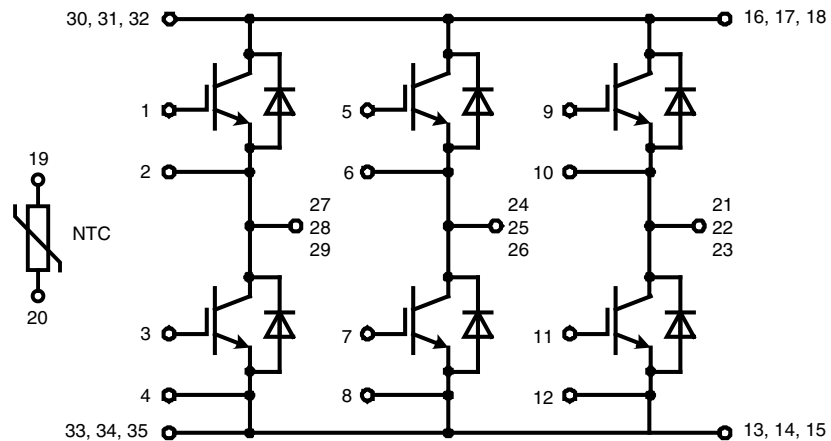

Outline Drawing Dimensions in mm (1 mm = 0.0394")

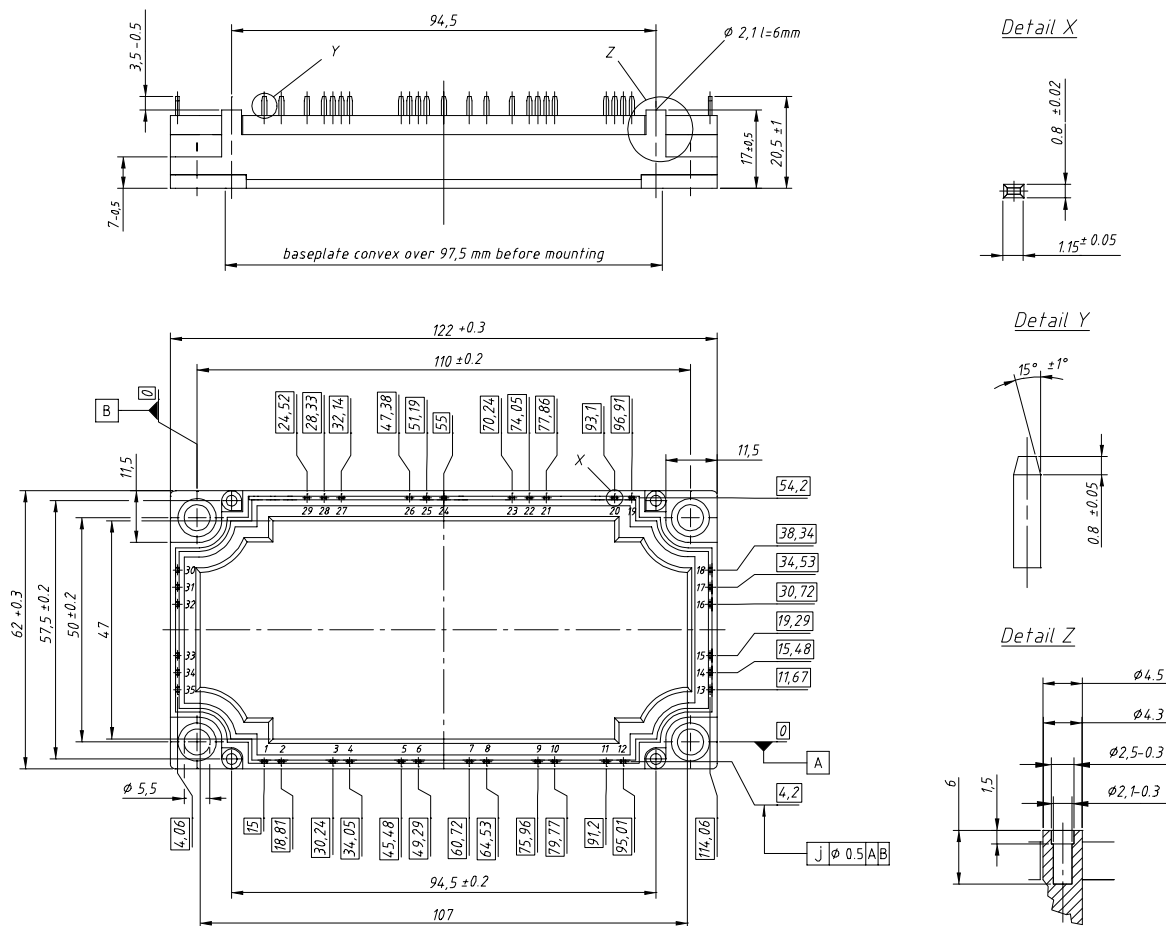

Product Marking

Ordering	Part Name	Marking on Product	Delivering Mode	Base Qty	Ordering Code
Standard	MWI150-12T8T	MWI150-12T8T	Box	5	502301

IXYS reserves the right to change limits, test conditions and dimensions.

20081209b

© 2008 IXYS All rights reserved

4 - 7

IXYS MWI150-12T8T

Inverter T1 - T6

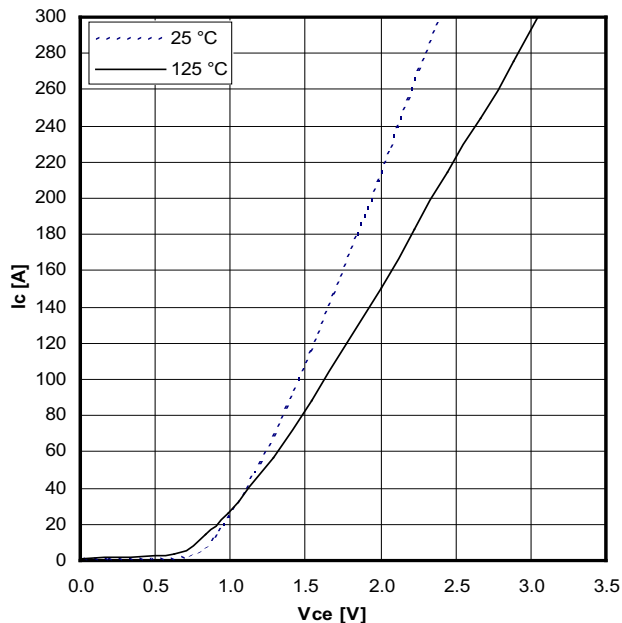

Typ. output characteristics

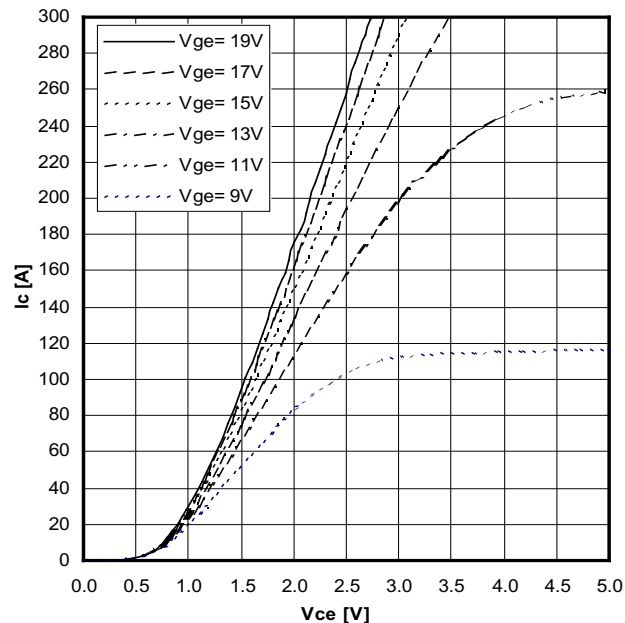

Typ. output characteristics

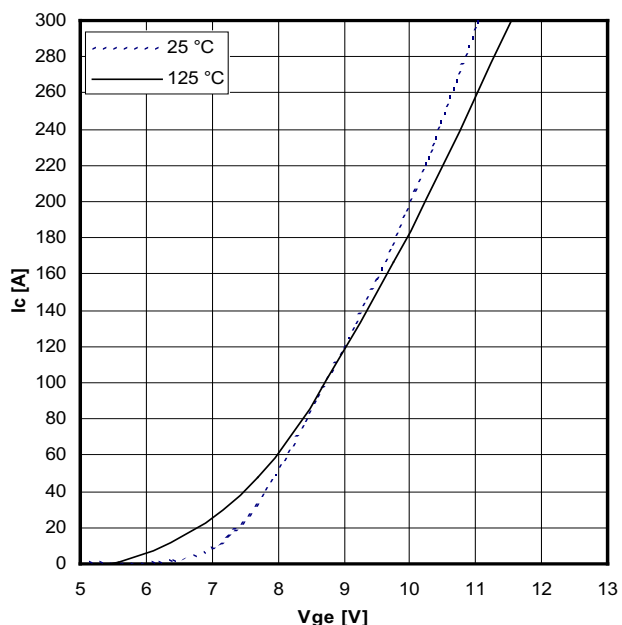

Typ. tranfer characteristics

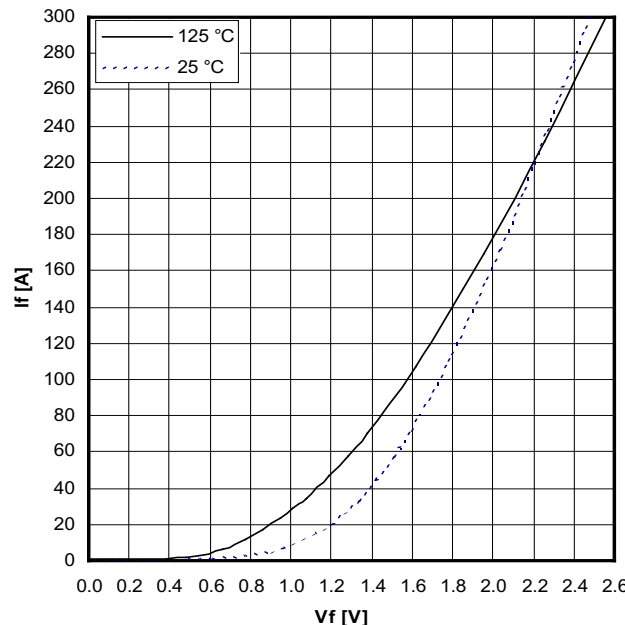

Typ. tranfer characteristics

IXYS reserves the right to change limits, test conditions and dimensions.

20081209b

© 2008 IXYS All rights reserved

5 - 7

IXYS MWI150-12T8T

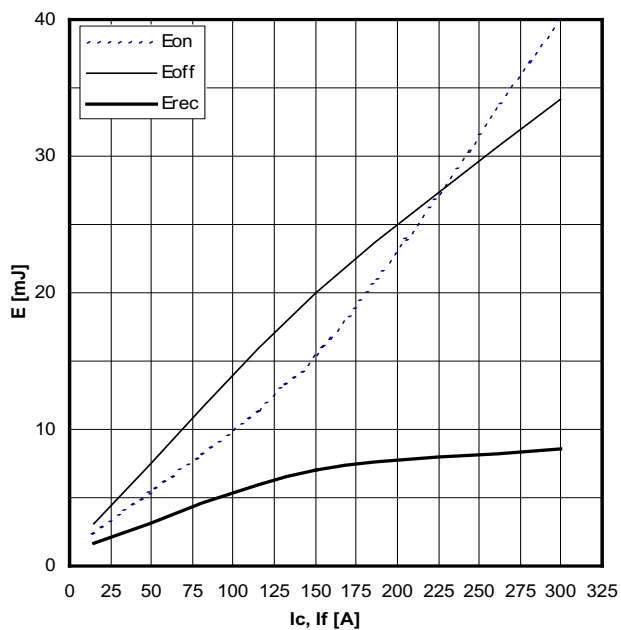

Typ. switching energy vs. collector current

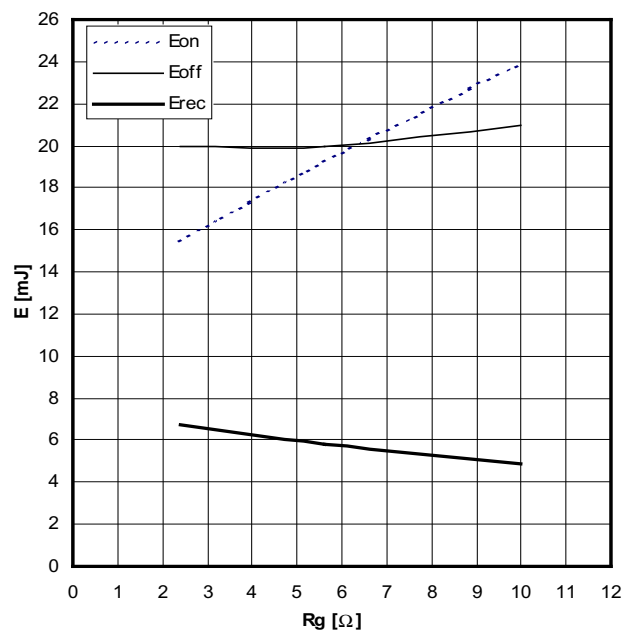

Typ. switching energy vs. gate resistance

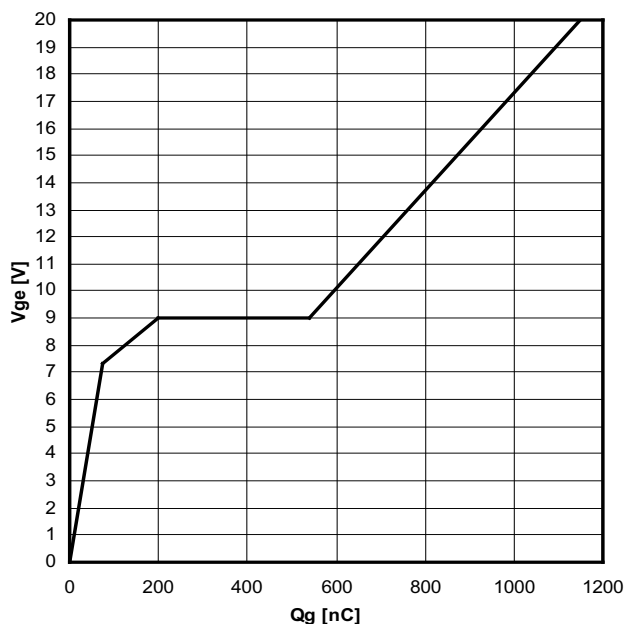

Typ. turn-on gate charge

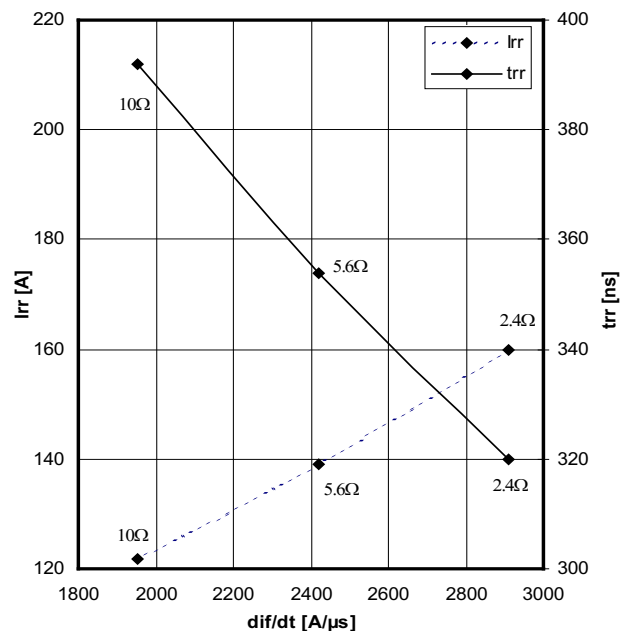

Reverse recovery characteristics

IXYS MWI150-12T8T

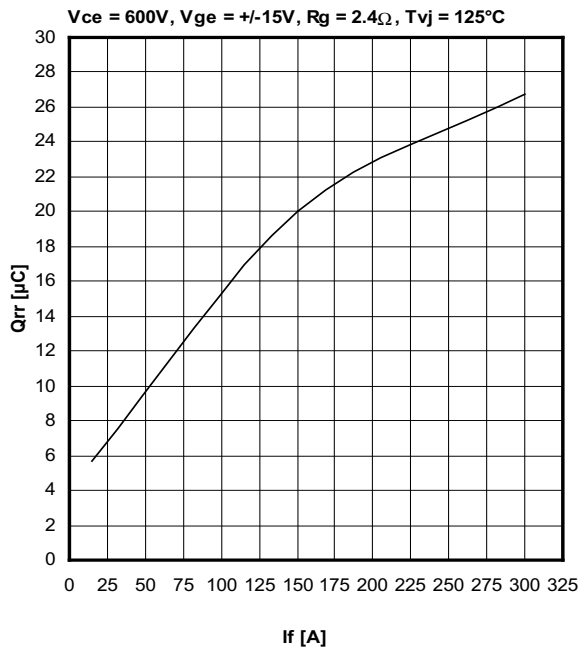

Reverse recovery characteristics

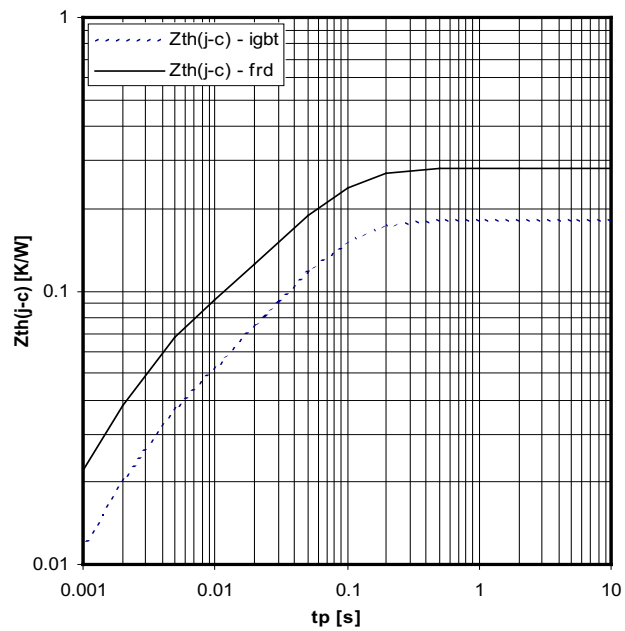

Typ. transient thermal impedance

NTC

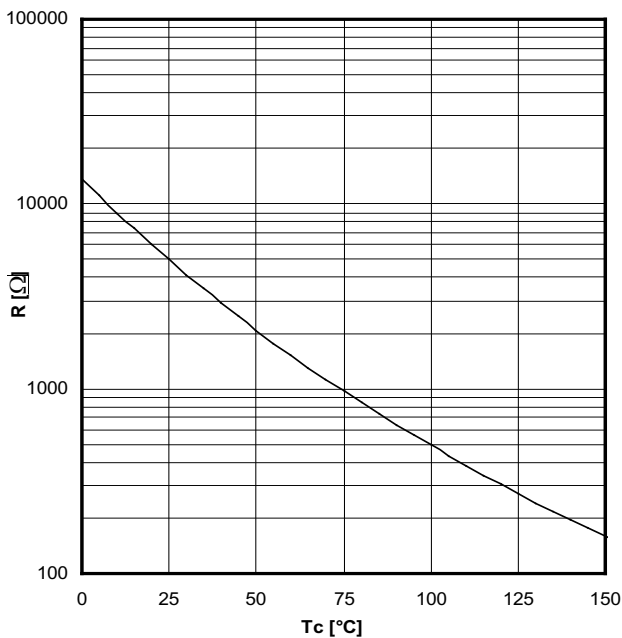

Typ. NTC resistance versus temperature