

SPECIFICATION

Device Name : IGBT Module

Type Name : 2MBI200SB-120

Spec. No. : MS5F 4921

This material and the information herein is the property of Fuji Electric Co., Ltd. They shall be neither reproduced, copied, lent, or disclosed in any way whatsoever for the use of any third party nor used for the manufacturing purposes without the express written consent of Fuji Electric Co., Ltd.

Fuji Electric Co., Ltd.
Matsumoto Factory

	DATE	NAME	APPROVED	Fuji Electric Co., Ltd.			
DRAWN	Nov. - 22 - '00	<i>T. Kobayashi</i>		<i>T. Miyasaka</i>	DWG. NO.	MS5F 4921	
CHECKED	Nov. - 22 - '00	<i>D. Mitsu</i>					1 / 8
							8

Revised Records

Date	Classi- fication	Ind.	Content	Applied date	Drawn	Checked	Approved
Nov.-22-'00	enactment	—	—————	Issued date	—	D. Myha	T. Miyasaka

This material and the information herein is the property of Fuji Electric Co., Ltd. They shall be neither reproduced, copied, lent, or disclosed in any way whatsoever for the use of any third party, nor used for the manufacturing purposes without the express written consent of Fuji Electric Co., Ltd.

2MBI200SB-120

1. Outline Drawing (Unit : mm)

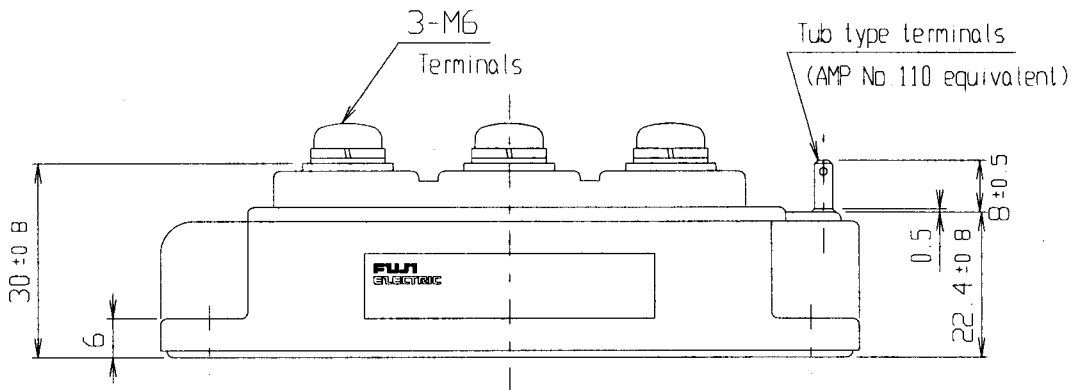
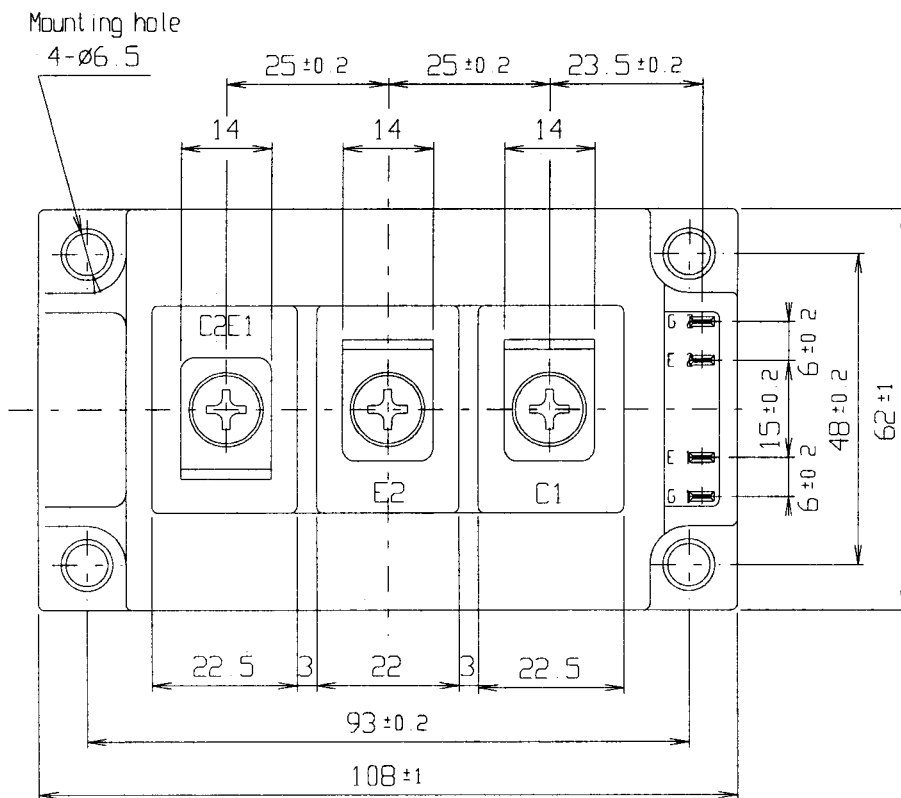

2. Equivalent circuit

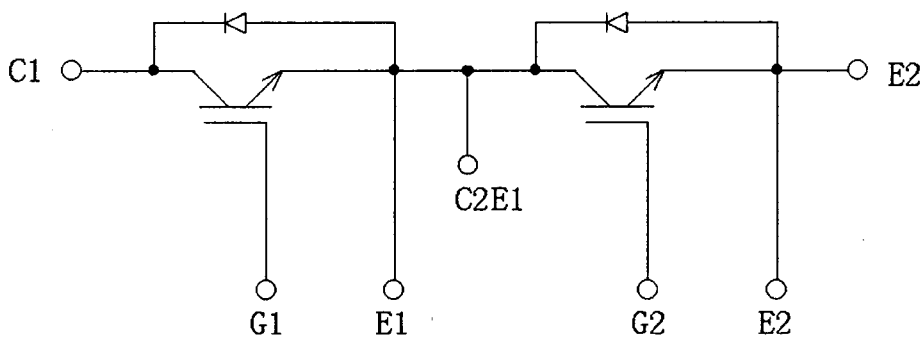

Fuji Electric Co.,Ltd.

DWG.NO.

MS5F 4921

3 / 8

3. Absolute Maximum Ratings (at Tc= 25C unless otherwise specified)

Items	Symbols	Conditions		Maximum Ratings		Units
Collector-Emitter voltage	VCES			1200		V
Gate-Emitter voltage	VGES			±20		V
Collector current	Ic	Continuous	Tc=25C	300	A	
			Tc=80C	200		
	Ic pulse	1ms	Tc=25C	600		
			Tc=80C	400		
	-Ic			200		
-Ic pulse	1ms		400			
Collector Power Dissipation	Pc	1 device		1500		W
Junction temperature	Tj			150		C
Storage temperature	Tstg			-40~ +125		C
Isolation voltage ^(*)	Viso	AC : 1min.		2500		V
Screw Torque	Mounting ^(*)			3.5		N·m
	Terminals ^(*)			4.5		

(*1) All terminals should be connected together when isolation test will be done.

(*2) Recommendable Value : Mounting 2.5~3.5 N·m (M5 or M6) / Terminal 3.5~4.5 Nm (M6)

4. Electrical characteristics (at Tj= 25C unless otherwise specified)

Items	Symbols	Conditions		Characteristics			Units	
				min.	typ.	Max.		
Zero gate voltage Collector current	ICES	VGE	0 V, VCE	1200 V	-	-	1.0	mA
Gate-Emitter leakage current	IGES	VCE	0 V, VGE	±20 V	-	-	0.4	µA
Gate-Emitter threshold voltage	VGE(th)	VCE	20 V, Ic =	200 mA	5.5	7.2	8.5	V
Collector-Emitter saturation voltage	VCE(sat)	VGE	15 V	Tj = 25 C	-	2.3	2.6	V
			Ic = 200 A	Tj = 125 C	-	2.8	-	
Input capacitance	Cies	VGE =	0 V		-	24000	-	pF
Output capacitance	Coes	VCE	10 V		-	5000	-	
Reverse transfer capacitance	Cres	f =	1 MHz		-	4400	-	
Turn-on time	ton	Vcc =	600 V		-	0.35	1.2	µs
	tr	Ic =	200 A		-	0.25	0.6	
	tr(0)	VGE	±15 V		-	0.1	-	
Turn-off time	toff	RG =	4.7 Ω		-	0.45	1.0	
	tf				-	0.08	0.3	
Forward on voltage	VF	IF =	200 A	Tj = 25 C	-	2.3	3.0	V
				Tj = 125 C	-	2.0	-	
Reverse recovery time	trr	IF =	200 A		-	-	0.35	µs

5. Thermal resistance characteristics

Items	Symbols	Conditions		Characteristics			Units
				min.	typ.	Max.	
Thermal resistance (1 device)	Rth(j-c)	IGBT		-	-	0.085	C/W
		FWD		-	-	0.18	
Contact Thermal resistance	Rth(c-f)	with Thermal Compound ^(*)		-	0.025	-	

* This is the value which is defined mounting on the additional cooling fin with thermal compound.

6. Indication on module

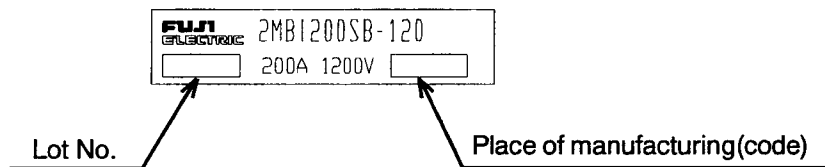

7. Applicable category (適用範囲)

This specification is applied to IGBT Module named 2MBI200SB-120.

本納入仕様書は IGBTモジュール 2MBI200SB-120 に適用する。

8. Storage and transportation notes (保管・運搬上の注意事項)

- The module should be stored at a standard temperature of 5 to 35°C and humidity of 45 to 75% .
 常温・常湿保存が望ましい。(5~35°C, 45~75%)
- Store modules in a place with few temperature changes in order to avoid condensation on the module surface.
 急激な温度変化のなきこと。(モジュール表面が結露しないこと)
- Avoid exposure to corrosive gases and dust.
 腐蝕性ガスの発生場所, 塵埃の多い場所は避けること。
- Avoid excessive external force on the module.
 製品に荷重がかからないように 十分注意すること。
- Store modules with unprocessed terminals.
 モジュールの端子は未加工の状態 で保管すること。
- Do not drop or otherwise shock the modules when transporting.
 製品の運搬時に衝撃を与えたり、落下させたりしないこと。
- Please connect adequate fuse or protector of circuit between three-phase line and this product to prevent the equipment from causing secondary destruction.
 万一の不慮の事故で素子が破壊した場合を考慮し、商用電源と本製品の間 に適切な容量のヒューズ又はブレーカーを必ず付けて 2次破壊を防いでください。

9. Definitions of switching time

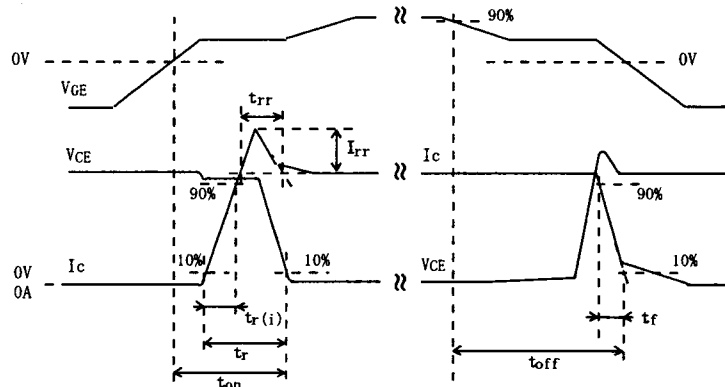
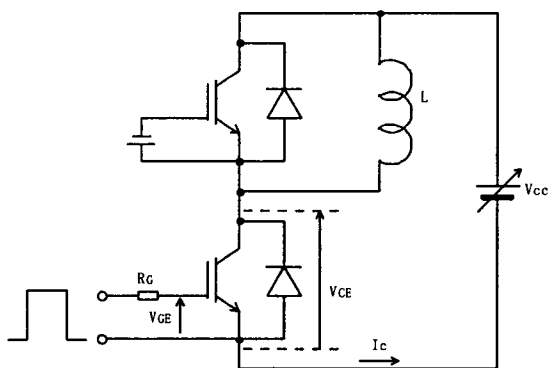

Fuji Electric Co.,Ltd.

DWG.NO.

MS5F 4921

5 / 8

This material and the information herein is the property of Fuji Electric Co., Ltd. They shall be neither reproduced, copied, lent, or disclosed in any way whatsoever for the use of any third party nor used for the manufacturing purposes without the express written consent of Fuji Electric Co., Ltd.

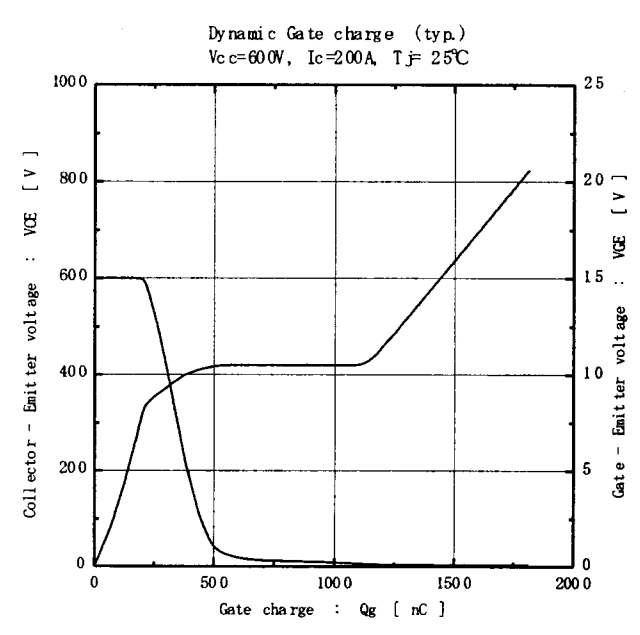
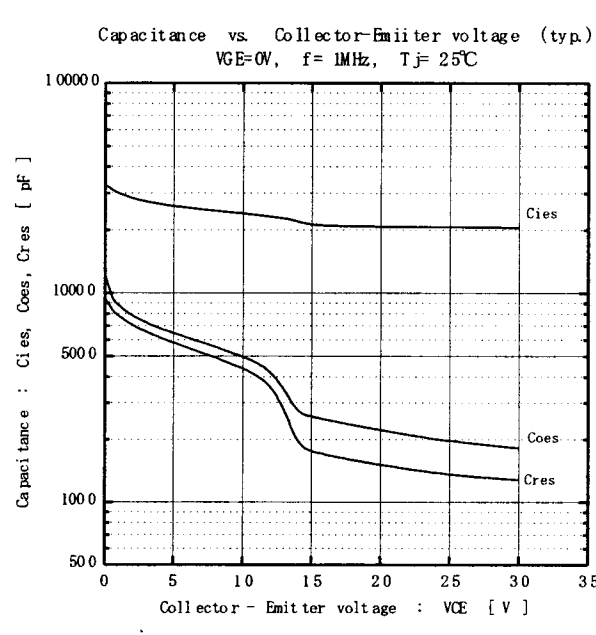
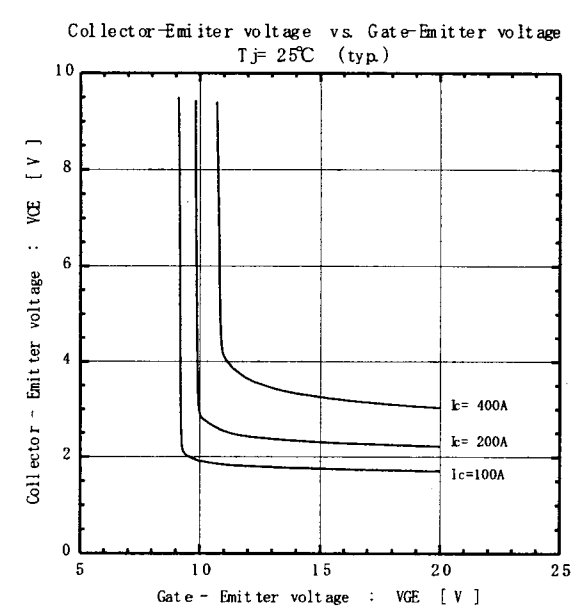
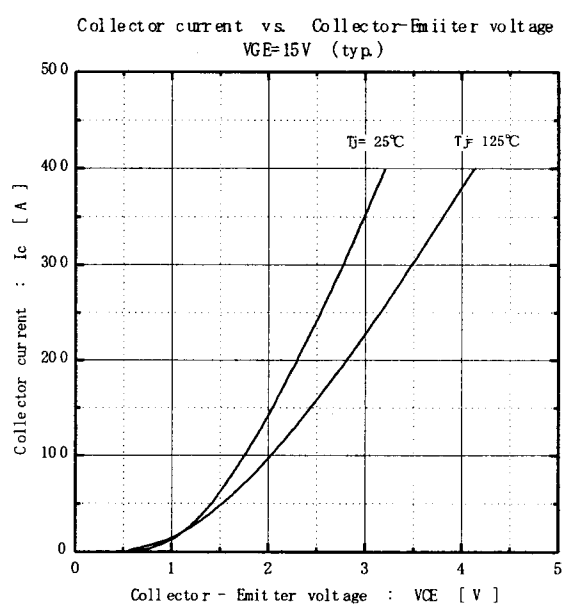
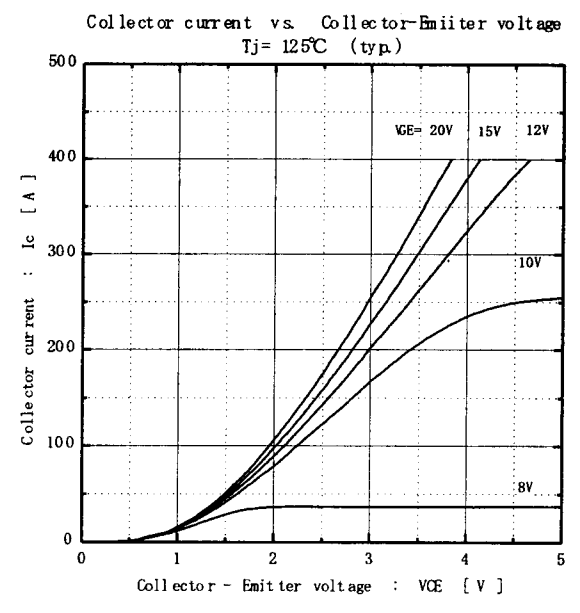
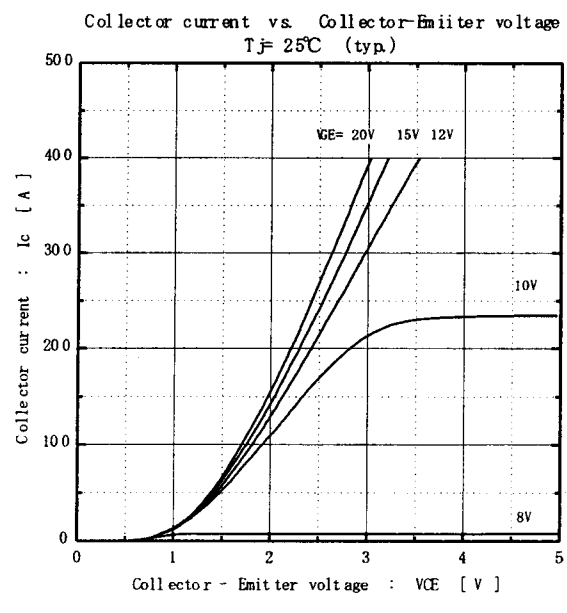

Fuji Electric Co., Ltd.

DWG. NO.

MS5F 4921

6 / 8

This material and the information herein is the property of Fuji Electric Co.Ltd.They shall be neither reproduced, copied, lent, or disclosed in any way whatsoever for the use of any third party nor used for the manufacturing purposes without the express written consent of Fuji Electric Co., Ltd.

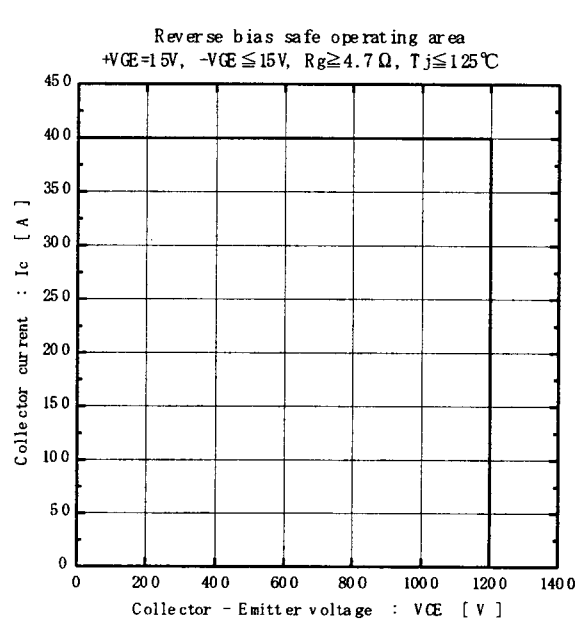
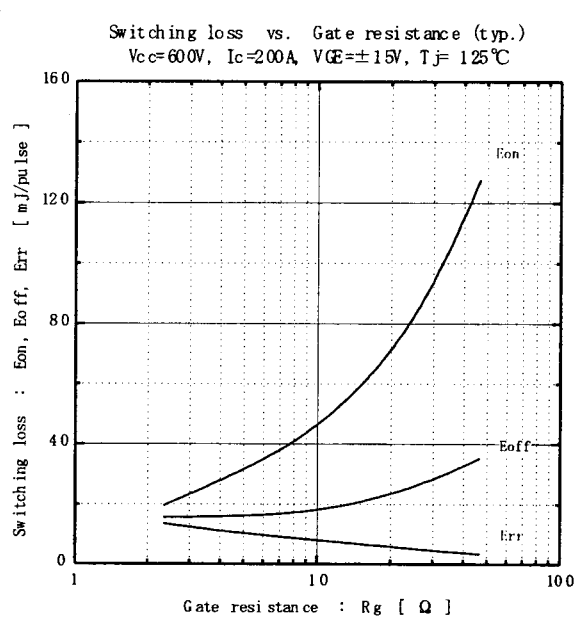
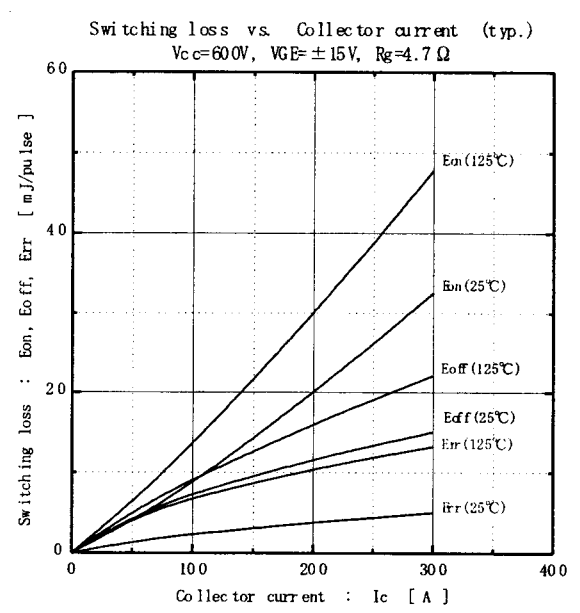
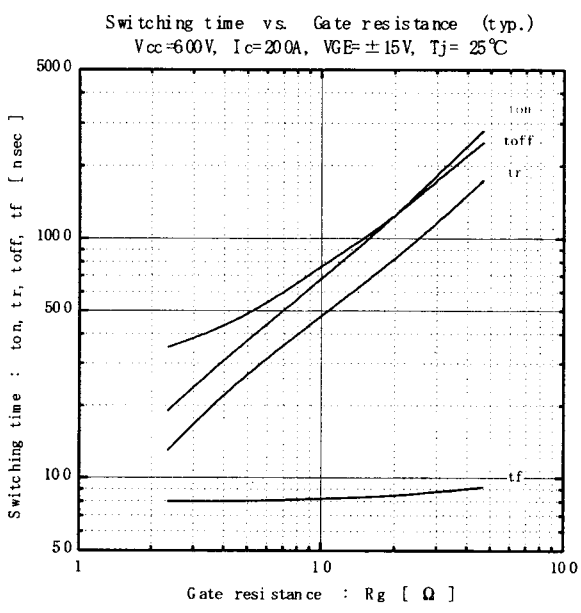
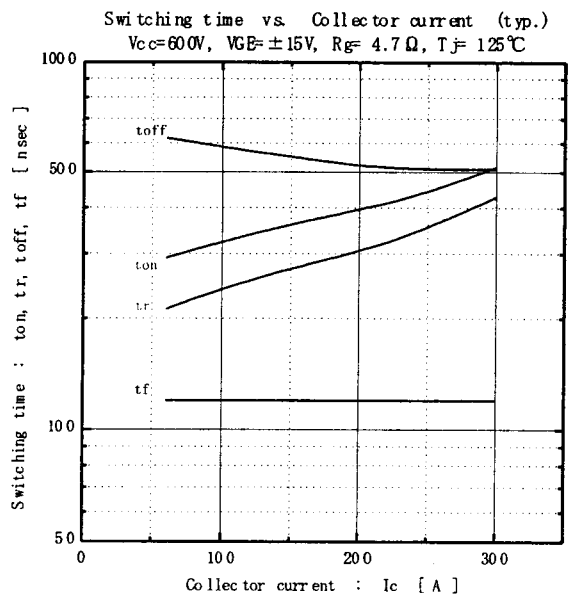
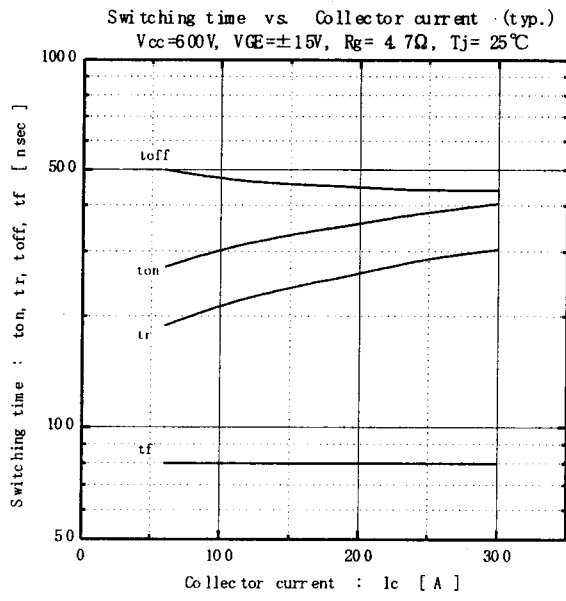

Fuji Electric Co.,Ltd.

DWG.NO.

MS5F 4921

7 / 8

Forward current vs. Forward on voltage (typ.)

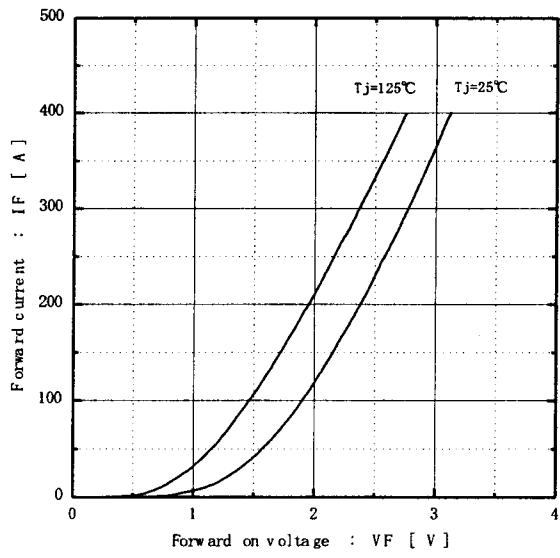

Reverse recovery characteristics (typ.)
Vcc=600V, VGE=±15V, Rg=4.7Ω

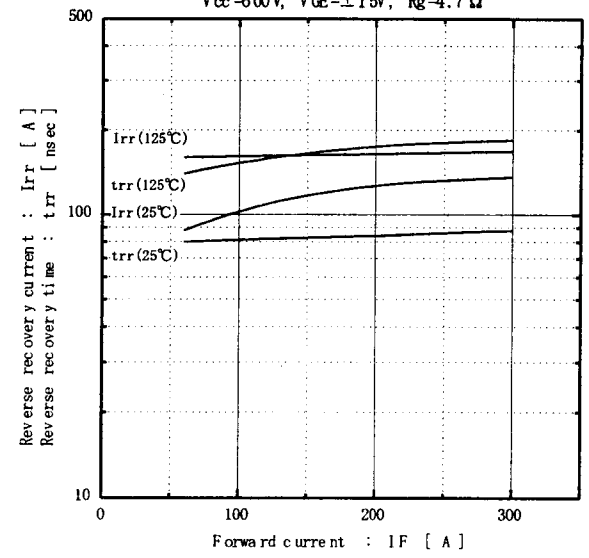

Transient thermal resistance

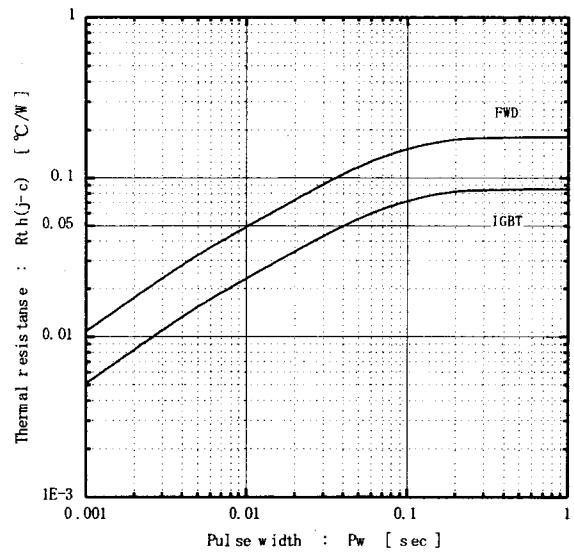

This material and the information herein is the property of Fuji Electric Co., Ltd. They shall be neither reproduced, copied, lent, or disclosed in any way whatsoever for the use of any third party, nor used for the manufacturing purposes without the express written consent of Fuji Electric Co., Ltd.

Fuji Electric Co., Ltd.

DWG. NO.

MS5F 4921

8 / 8