

HF9519**1/5 CUBIC INCH 2 FORM C
HERMETICALLY SEALED ELECTRO MAGNETIC RELAY****Features**

- Force balanced
- 5A contacts switching capability
- Failure rate level can be level L
- High ambient applicability
- All metal welded construction
- Hermetically welded and marked by laser

AMBIENT ADAPTABILITY

Ambient grade	I	II	III
Ambient temperature	-55 °C to 85 °C	-55 °C to 85 °C	-65 °C to 125 °C
Humidity	98%, 40 °C		
Low air pressure	58.53 kPa	4.39 kPa	4.39 kPa
Sine vibration	Frequency	10 Hz to 1000 Hz	10 Hz to 2000 Hz
	Acceleration	147 m/s ²	196 m/s ²
Shock resistance	490 m/s ²	980 m/s ²	1960 m/s ²
Random vibration	10 (m/s ²) ² /Hz	20 (m/s ²) ² /Hz	40 (m/s ²) ² /Hz
Steady-state acceleration	147 m/s ²	294 m/s ²	490 m/s ²

CONTACT DATA

Ambient grade	I	II	III
Arrangement	2 C		
Contact resistance or voltage drop	Initial max.	0.05Ω	
	After life max.	0.125V	
Failure level	Level L		

Contact and life ratings

Type	Contact load		Electrical life min.
	28Vd.c.	115Va.c. 400Hz Single phase	
Resistive	5A	5A	1 x 10 ⁵ ops
Inductive	3A	5A	2 x 10 ⁴ ops
Motor	2A		1 x 10 ⁵ ops
Lamp load	1A		1 x 10 ⁵ ops



HONGFA HERMETICALLY SEALED RELAY

SPECIFICATION

Ambient grade		I	II	II
Insulation resistance min.	Initial	100 MΩ (@ 500 Vd.c.)	100 MΩ (@ 500 Vd.c.)	100 MΩ (@ 500 Vd.c.)
	After life or after testing	50 MΩ (@ 500 Vd.c.)	50 MΩ (@ 500 Vd.c.)	50 MΩ (@ 500 Vd.c.)
Dielectric strength min. (Normal condition)	Between coil & cover (initial)	1000 Vr.m.s.	1000 Vr.m.s.	1000 Vr.m.s.
	Between coil & cover (after life testing)	750 Vr.m.s.	750 Vr.m.s.	750 Vr.m.s.
Dielectric strength min. (Low air pressure condition)		250 Vr.m.s.	250 Vr.m.s.	250 Vr.m.s.
Leakage rate max.		1 Pa·cm ³ /s	1 x 10 ⁻¹ Pa·cm ³ /s	1 x 10 ⁻³ Pa·cm ³ /s
Operate time max.				6 ms
Release time max.				6 ms
Mounting style				See the mounting dimension
Terminals				See the terminal styles
Work position				Random
Weight max.				20.4 g

COIL DATA

Normal coil power	Approx. 2W
-------------------	------------

Coil Version

Order Number	Coil voltage		at 25 °C				-65°C to 125°C			Pick-up voltage max.	
	Nominal voltage	Value max.	Coil resistance (Ω) min.	Pick-up voltage max.	Hold voltage max.	Drop-out voltage min.	Pick-up voltage max.	Hold voltage max.	Drop-out voltage min.	High temp. test	Continuous electric test
006	6	7.3	18	3.3	1.6	0.50	4.5	2.3	0.25	5.0	5.70
012	12	14.5	85	6.5	3.3	0.75	9.0	4.5	0.50	9.9	11.25
028	28	29.0	450	15.5	5.5	2.30	20.0	7.0	1.50	21.0	25.0

Notes: We can offer many kinds of coil voltage under the requirement of users.

ORDERING INFORMATION

Type	HF9519	-012	L	-0	1	-II
Order Number	006、012、028					
Failure Rate	L (level III products available)					
Mounting Style	0, 2, 3 (See the mounting dimension)					
Terminals Style	1, 4 (See " Terminal styles " below)					
Ambient Grade	I : level I II : level II Nil: level III (With failure rate requirement)					

OUTLINE DIMENSIONS AND WIRING DIAGRAM

Unit:mm

Outline Dimension

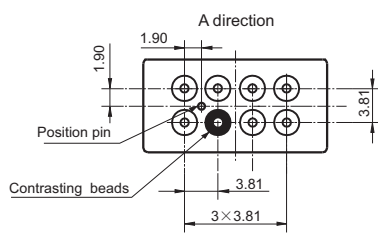
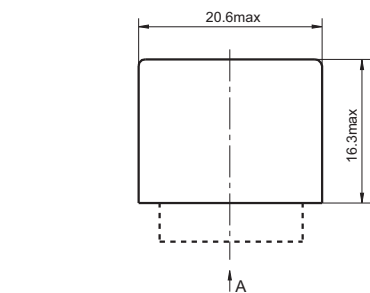

Mouting style 0

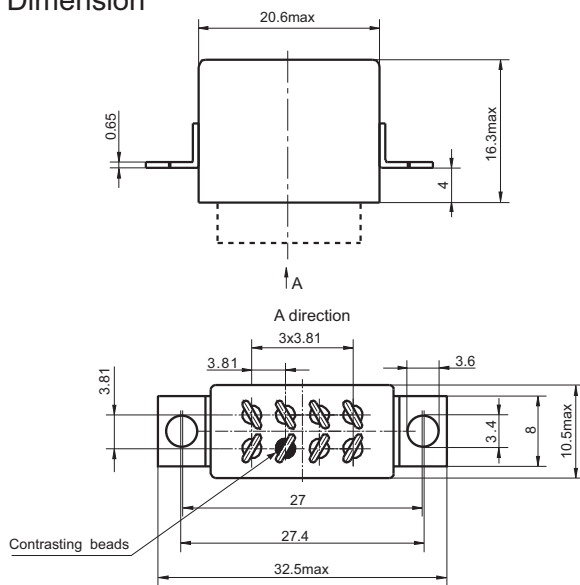

Mouting style 2

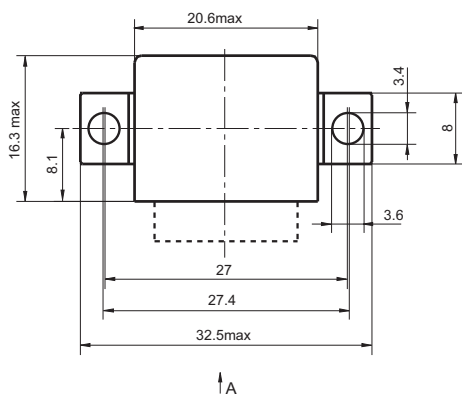

Mouting style 3

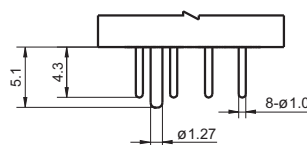
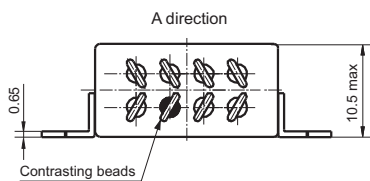

Terminal style 1
(Solder pin)

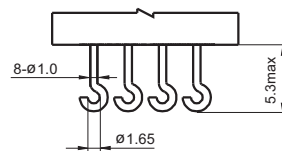

Terminal style 4
(Solder hook)

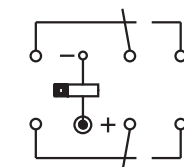

Wiring Diagram
(Bottom View)

Disclaimer

This datasheet is for the customers' reference. All the specifications are subject to change without notice.

© Xiamen Hongfa Electroacoustic Co., Ltd. All rights of Hongfa are reserved.